





27  
376











16715

PUBLICATIONS SCIENTIFIQUES-INDUSTRIELLES DE E. LACROIX

# COURS DE CONSTRUCTION

PAR A. DEMANET

Lieutenant-colonel du Génie

3<sup>e</sup> ÉDITION COMPLÈTEMENT REFONDUE ET CONSIDÉRABLEMENT AUGMENTÉE

**ATLAS**

PARIS

LIBRAIRIE SCIENTIFIQUE, INDUSTRIELLE ET AGRICOLE

**Eugène LACROIX, Imprimeur-Éditeur**

LIBRAIRE DE LA SOCIÉTÉ DES INGÉNIEURS CIVILS, DE CELLE DES ANCIENS ÉLÈVES DES ÉCOLES D'ARTS ET MÉTIERS, DE LA SOCIÉTÉ DES CONDUCTEURS DES PONTS ET CHAUSSEES

DE MM. LES MÉCANICIENS DE LA MARINE IMPÉRIALE, ETC., ETC

54, RUE DES SAINTS-PÈRES, 54

IMPRIMERIE A SAINT-NICOLAS-DE-PORT (MEURTHE)

1871

Droits de traduction et de reproduction réservés



PUBLICATIONS SCIENTIFIQUES INDUSTRIELLES DE LA MAISON

COURS

DE CONSTRUCTION

PAR A. DEMANET

Professeur au Collège

SPÉCIMEN COMPLÈTEMENT REPOUSSE ET CONSIDÉRABLEMENT AUGMENTÉ

ATLAS

PARIS

LIBRAIRIE SCIENTIFIQUE INDUSTRIELLE ET AGRICOLE  
Eugène LACROIX, Ingénieur-Architecte

Le présent ouvrage est le résultat de longues années de travaux pratiques et de recherches approfondies. Il est divisé en deux parties : la première traite de la construction des machines à vapeur, et la seconde de la construction des machines à gaz et à pétrole. L'auteur a eu l'honneur de faire partie de la Commission chargée de l'enseignement de la mécanique industrielle à l'École Polytechnique, et de la Commission chargée de l'enseignement de la mécanique industrielle à l'École des Arts et Métiers. Il a également été professeur à l'École des Mines de Paris, et à l'École des Arts et Métiers de Paris. L'ouvrage est accompagné de nombreux dessins et figures qui ont été soigneusement gravés sur acier.



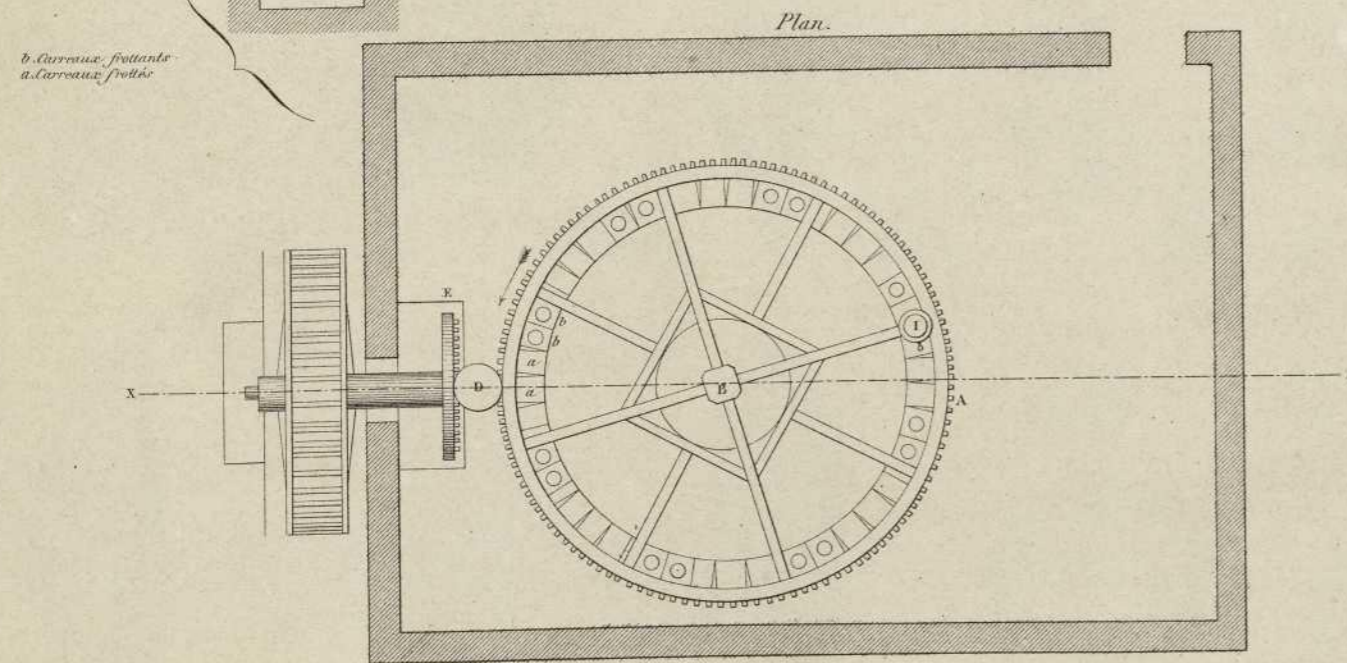
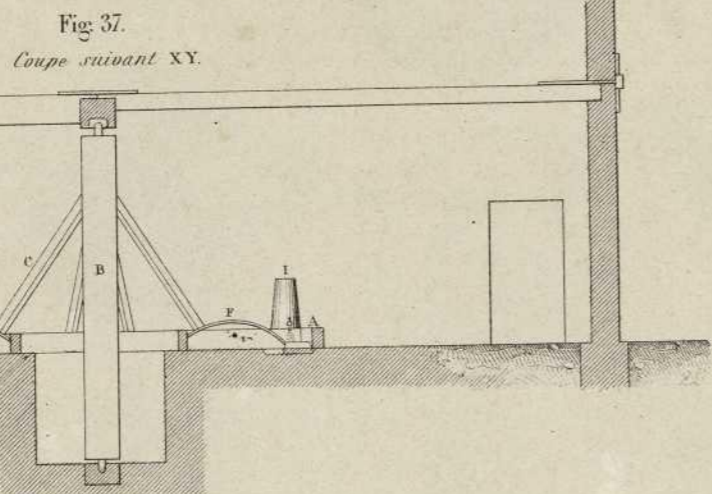
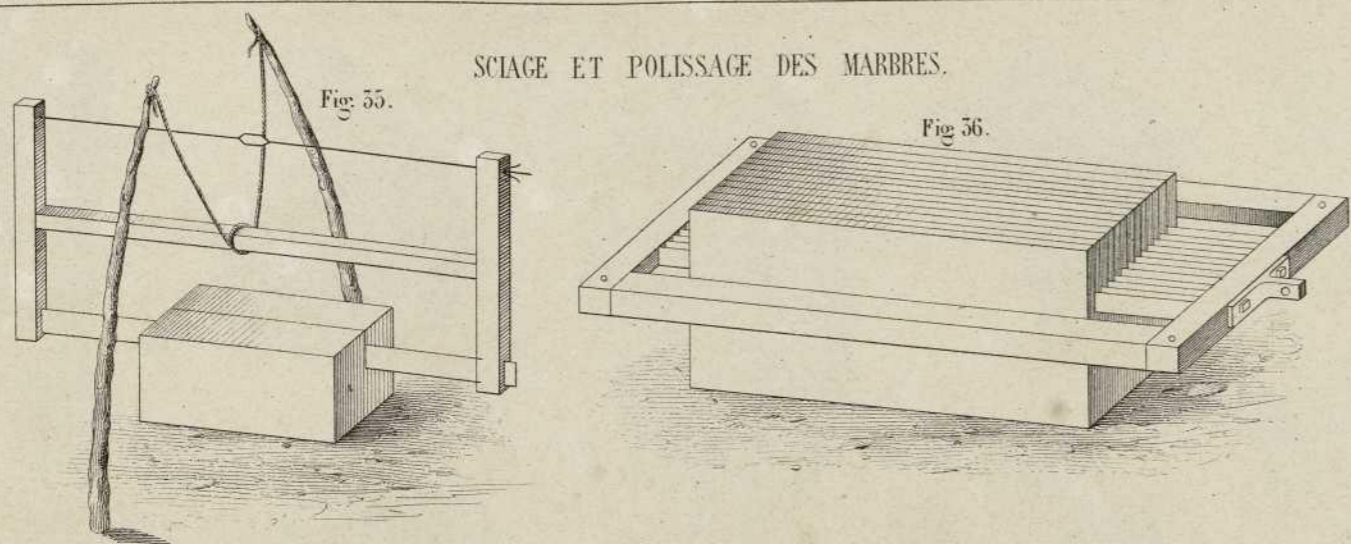








SCIAGE ET POLISSAGE DES MARBRES.



CUISSON DU CALCAIRE ET DU GYPSE.

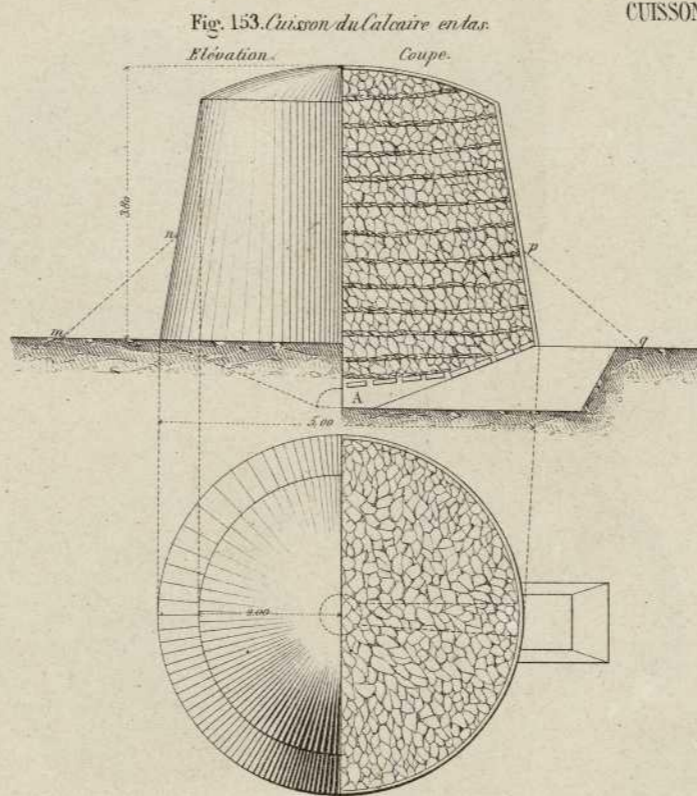


Fig. 153. Cuisson du Calcaire en tas.

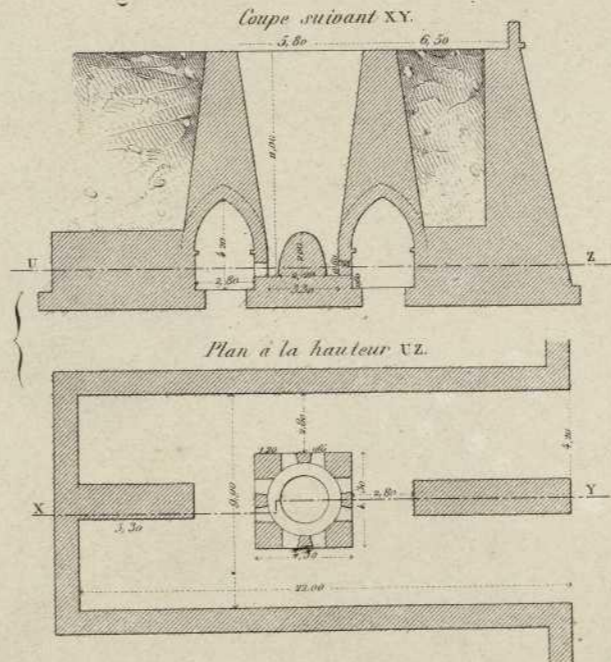
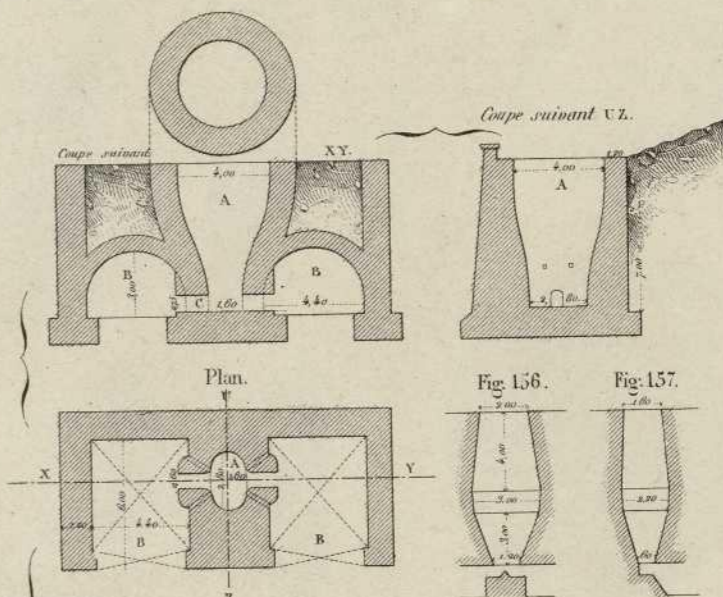


Fig. 155. Four coulant des environs de Tournay.

Fig. 154. Four coulant des environs de Namur.



A Cuisson  
B Chambres voûtées dans lesquelles on fait tomber la pierre calcinée.  
C Orifaces par où l'on fait tomber la pierre calcinée.

Fig. 159. Four intermittent chauffé à la tourbe.

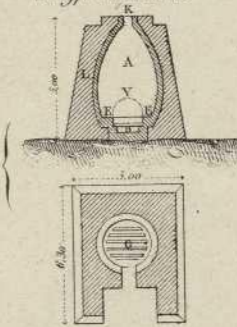


Fig. 158. Four intermittent chauffé au bois.

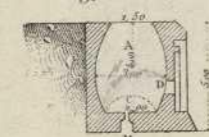
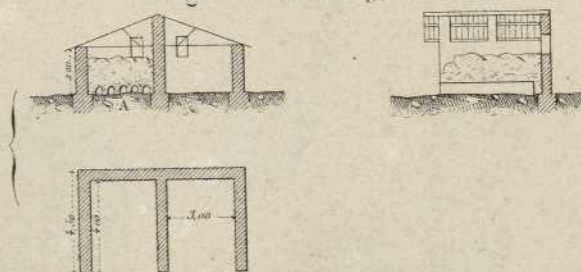


Fig. 160. Cuisson du Gypse.



Echelle de 0,01 pour 1 mètre, pour les Fig. 154 à 160.















Les Pl. III et IV offrent réunis les fossiles principaux et caractéristiques de tous les terrains.

## PLANCHE III

### Terrains Silurien, Dévonien, Carbonifère, Permien et Triasique.

- Fig. 38. — *Dalmanites socialis*, Barr.  
39. — *Orthoceras gregarioides*, d'Orb.  
40. — *Lituites simplex*, Barr.  
41. — *Orthis irregularis*, Barr.  
42. — *Graptolites peregrinus* et *prionon*, Barr.  
43. — *Retepora* ined.  
44. — *Goniatites retrorsus*, de Buch.  
45. — *Clymenia undulata*, Münst.  
46. — *Macrocheilus areolatus*, Schloth.  
47. — *Spirifer Verneuillii*, Murch.  
48. — *Pleurodictium problematicum*, Goldf.  
49. — *Calceola sandalina*, Lamk.  
50. — *Bellerophon hiulcus*, Sow.  
51. — *Productus cora*, De Kon.  
52. — *Pecopteris*.  
53. — *Nevropteris*.  
54. — *Sphenopteris*.  
55. — *Lepidodendron Sternbergii*.  
56. — *Calamites Suckovii*, Brong.  
57. — *Productus horridus*, Sow.  
58. — *Noeggarathia cuneifolia*, Brong.  
59. — Écaille de poisson : *Pygopterus*.  
60. — Dent de *Palaosaurus plotyodon*.  
61. — Pas de *Cheirotherium*.  
62. — *Avicula socialis*, Alberti.  
63. — *Encrinites liliiformis*, Schloth.  
64. — *Posidonomya minuta*, Bronn.  
65. — *Myophoria vulgaris*, Bronn.  
66. — *Ceratites* (amm.) *nodosus*, Haan.

### Terrains jurassiques.

67. — *Pholadomya Murchisoni*, Sow.  
68. — Vertèbre d'*Ichtyosaurus communis*.  
69. — Phalange de nageoire, du même.  
70. — *Melania striata*, Sow.  
71. — Dent d'*Ichtyosaurus*.  
72. — Vertèbre de *Plesiosaurus dolichodeirus*, Conyb.  
73. — Phalange de nageoire, id.  
74. — *Trigonia navis*, Lamk.  
75. — *Ammonites bifrons*, Brug.  
76. — *Belemnites hastatus*, Blainv.  
77-78. — *Terebratula digona*, Sow.  
79. — *Cidaris Blumenbachii*, Münst.  
80. — Radiole, id.  
81. — *Ammonites Parkinsoni*, Sow.  
82. — *Pleuromya elongata*, Ag.  
83. — *Ammonites cordatus*, Sow.  
84. — *Gryphea arcuata*, Sow.  
85. — *Palinurus squamifer*, E. Desl.  
86. — *Gryphea cymbium*, Lamk.  
87. — *Perna mytiloides*, Lamk.  
87 bis. — *Nerinea Brontrutana*, Thurm.  
88. — *Ostrea acuminata*, Sow.  
89. — *Astrea helianthoides*, Goldf.  
90. — *Thecosmilia annularis*, Haime et Edw.  
91. — *Gryphea dilatata*, Sow.  
92-93. — Tige d'*Apiocrinites rotundus*.  
94. — *Ostrea deltoidea*, Sow.  
95. — *Ficeras arietina*, Lamk. moule int.  
96. — *Pterocera Pontii*, d'Orb.  
97. — *Physa Bristovii*, Forbes.  
98. — *Ceromya excentrica*, Voltz.  
99. — *Gervillia aviculoides*, Sow.  
100. — *Exogyra virgula*, Goldf.

## PLANCHE IV

### Terrains crétacés.

101. — *Ammonites Mantelli*, Sow.  
102. — *Ammonites Rhotomagensis*, Lamk.  
103. — *Scaphites aequalis*, Sow.  
104. — *Scaphites Ivanii*, Puzos.  
105. — *Nautilus Danicus*, Schloth.  
106. — *Belemnitella mucronata*, d'Orb.  
107. — *Terebrirostra lyra*, d'Orb.  
108. — *Sphaerulites calceoloides*, Desmoul.  
109. — *Turrilites costatus*, Lamk.  
110. — *Hamulina*, sp. ined.  
111. — *Belemnites dilatatus*.  
112. — *Hippurites radiosus*, Desmoul.  
113. — *Unio Valdensis*, Mantell.  
114. — *Janira quadricostata*, d'Orb.  
115. — *Toxaster Brunneri*, Merian.  
116-117. — *Coprolites*.  
118. — *Anachytes ovata*, Lamk. (*Echinobrissus vulgaris*, Breyn.)  
119. — *Magas pumilus*, Sow.  
120. — *Ostrea carinata*, Lamk.  
121. — *Rhynchonella octoplicata*, d'Orb.  
122. — *Micraster coranguinum*, Ag.  
123. — *Trigonia scabra*, Lamk.

### Terrains tertiaires et Diluvium.

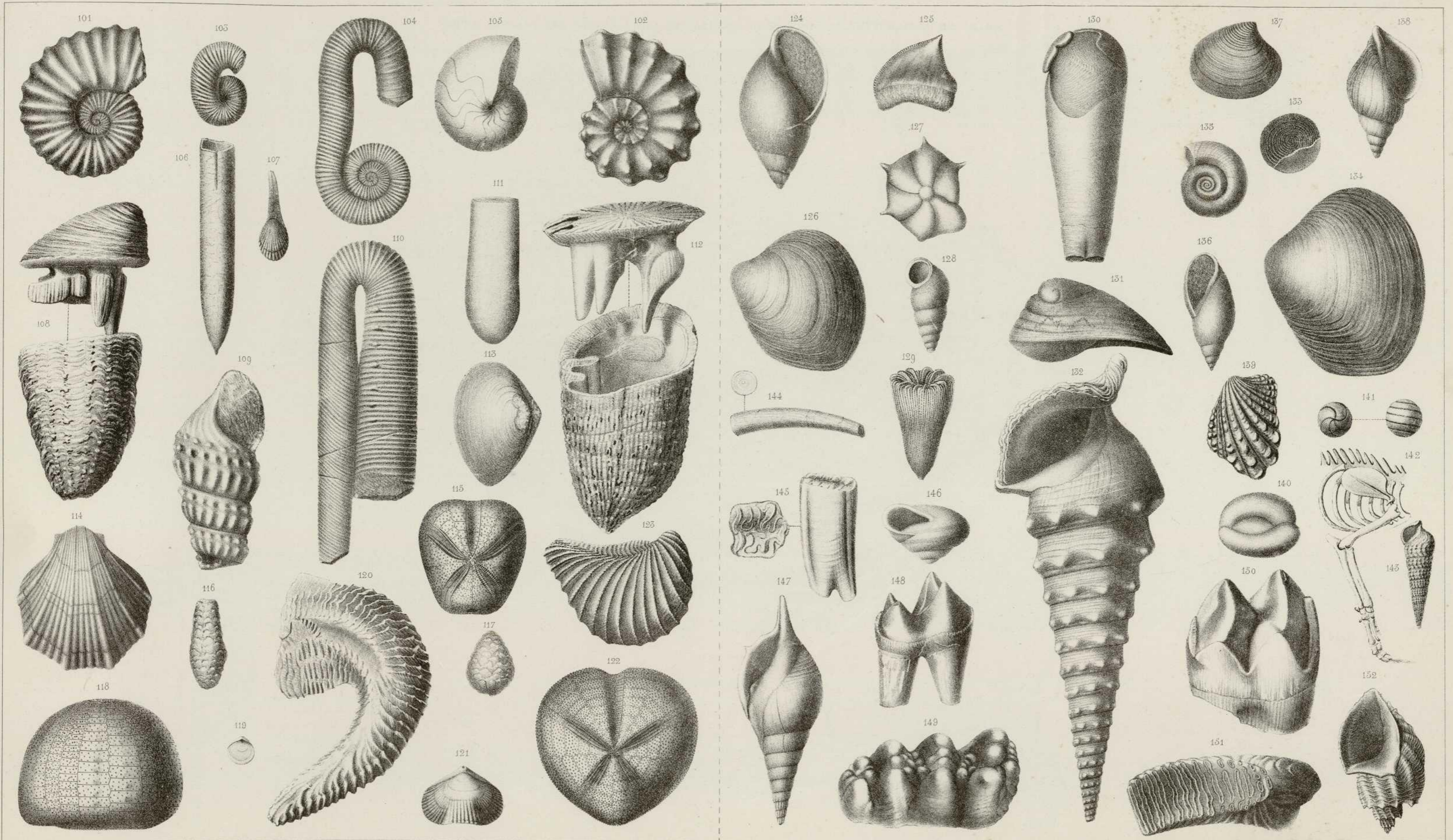
124. — *Physa gigantea*, Michaud.

125. — *Corax pristodontus*, Ag.  
126. — *Cyrena Gravesii*, Desh.  
127. — *Calcarina rarispina*, Desh.  
128. — *Cyclostoma mumia*, Lamk.  
129. — *Turbinolia elliptica*, A. Brong.  
130. — *Teredina personata*, Lamk.  
131. — *Nerita conoidea*, Lamk.  
132. — *Cerithium giganteum*, Lamk.  
133. — *Nummulites laevigata*, Lamk.  
134. — *Crassatella tumida*, auct. (*Plumbea*, Desh.)  
135. — *Planorbis rotundatus*, A. Brong.  
136. — *Lymnea longiscata*, A. Brong.  
137. — *Astarte bipartita*, Sow.  
138. — *Fusus contrarius*, Sow.  
139. — *Cardita crassa*, Lamk.  
140. — *Triloculina inflata*, Desh.  
141. — *Chara medicaguula*, A. Brong.  
142. — Membre ant. droit d'*Anoplotherium*.  
143. — *Potamides Danarekii*, Desh.  
144. — Défense d'éléphant fossile.  
145. — Dent de cheval id.  
146. — *Helix Turonensis*, Desh.  
147. — *Rostellaria dentata*, Grat.  
148. — Deuxième arr. molaire droite de *Cryptodon*.  
149. — Molaire de *Mastodonte*.  
150. — Molaire de *Dinotherium*.  
151. — Molaire d'*Elephas primigenius*.  
152. — Cancellaire : Sables de Bordeaux.

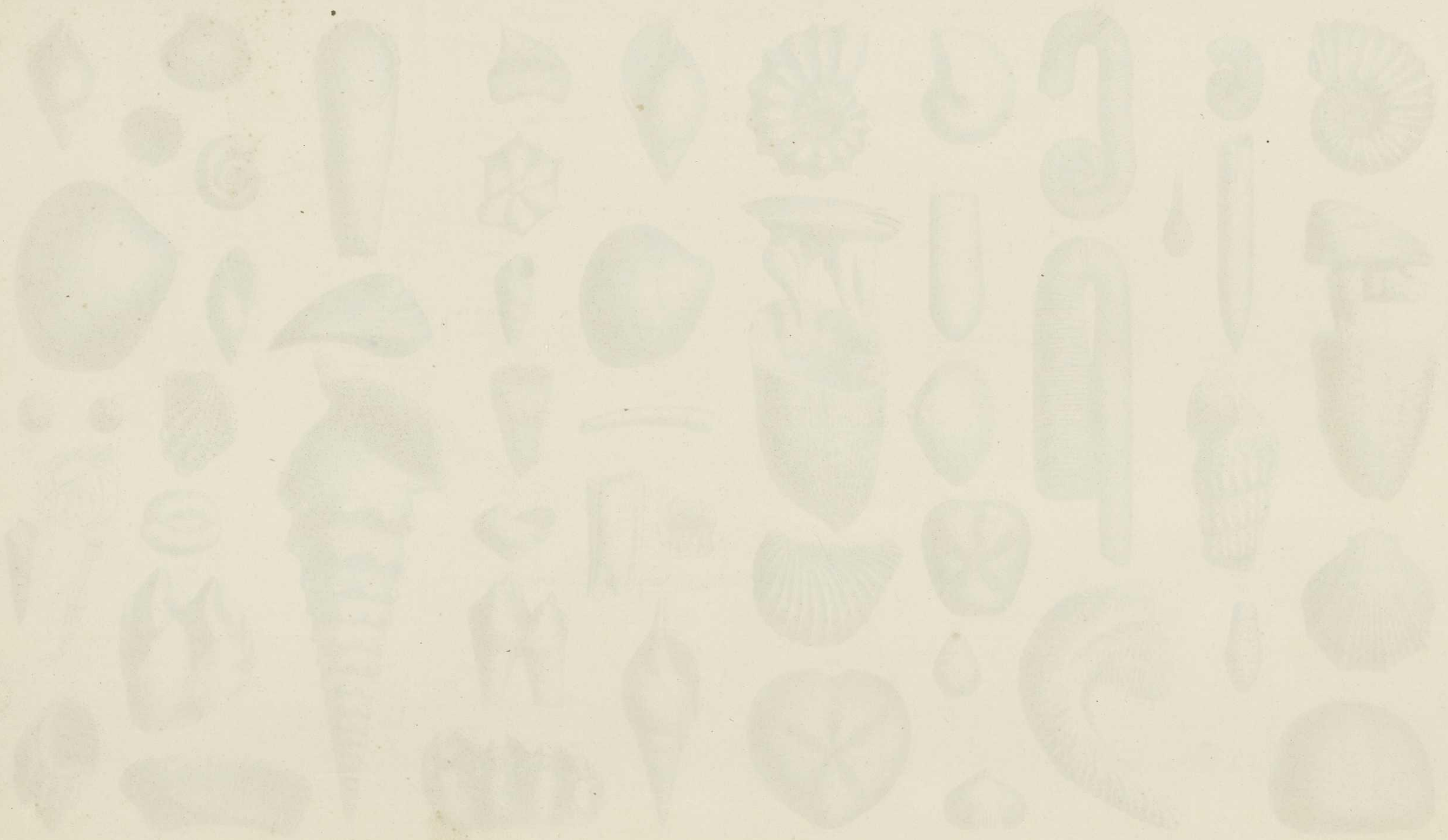














COÛPE PASSANT PAR BRUGES, GAND, BRUXELLES, NAMUR, DINANT, NEUFCHATEAU ET ARLON.

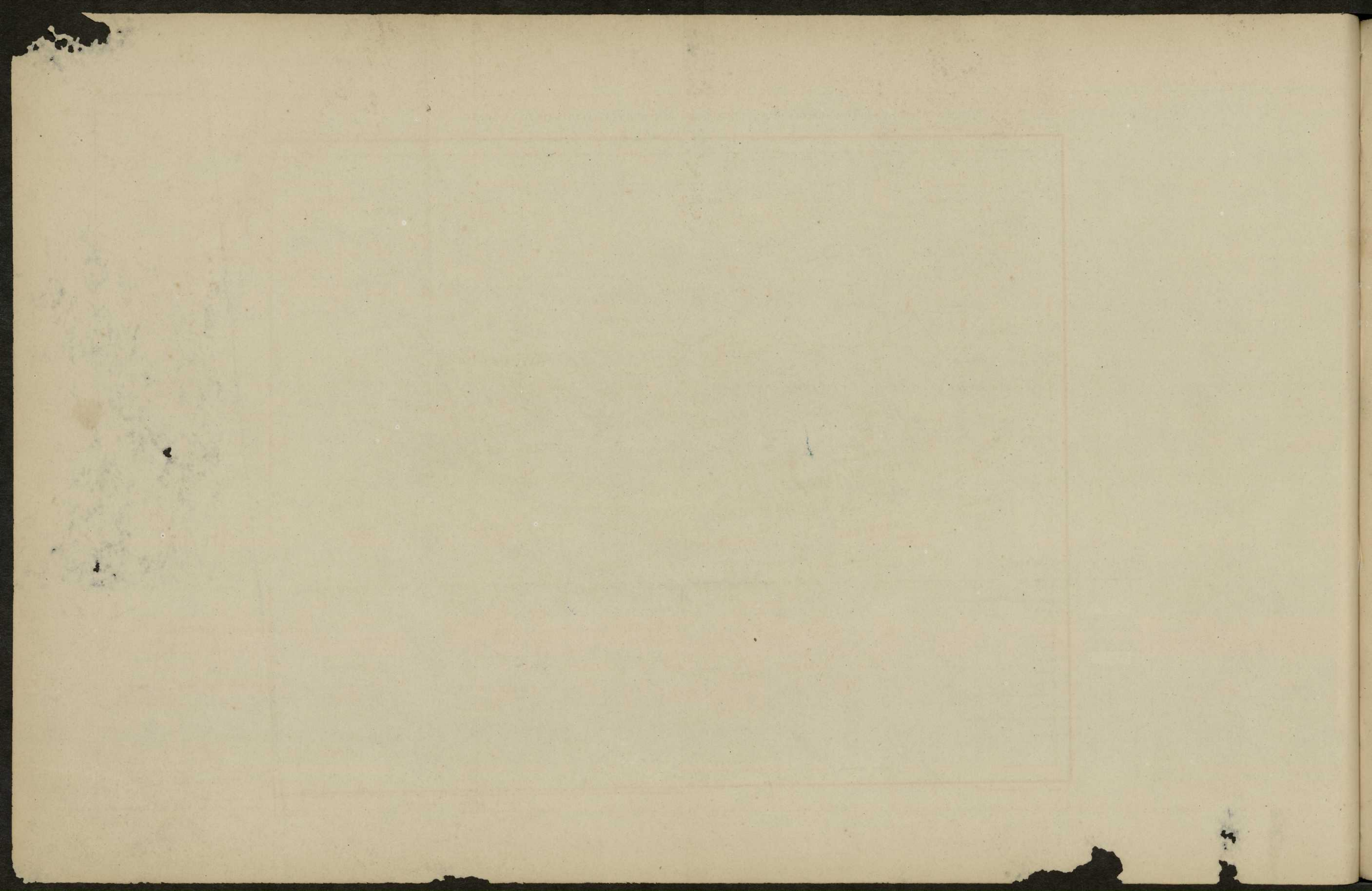


Explication des Couleurs.

Zones	12	Terrains modernes et tertiaires supérieurs.	} Terrain Antra.cifère	
	11	Calcaires grossiers, grès fistuleux (terrain parisien)		
	10	Grès ferrugineux		
	9	Terrain crétacé		
	Méri-dionale	8		jurassique
		7		de trias
		6		ponien
	Centrale	5		houiller
		4		Calcaire de Visé
		3		de Givet et psammites du Condre
		2		Poudingue de Burzet
		1		Terrain ardoisier, Grauwacke et Schiste
Limites des Zones		••••	••••	Roches porphyriques

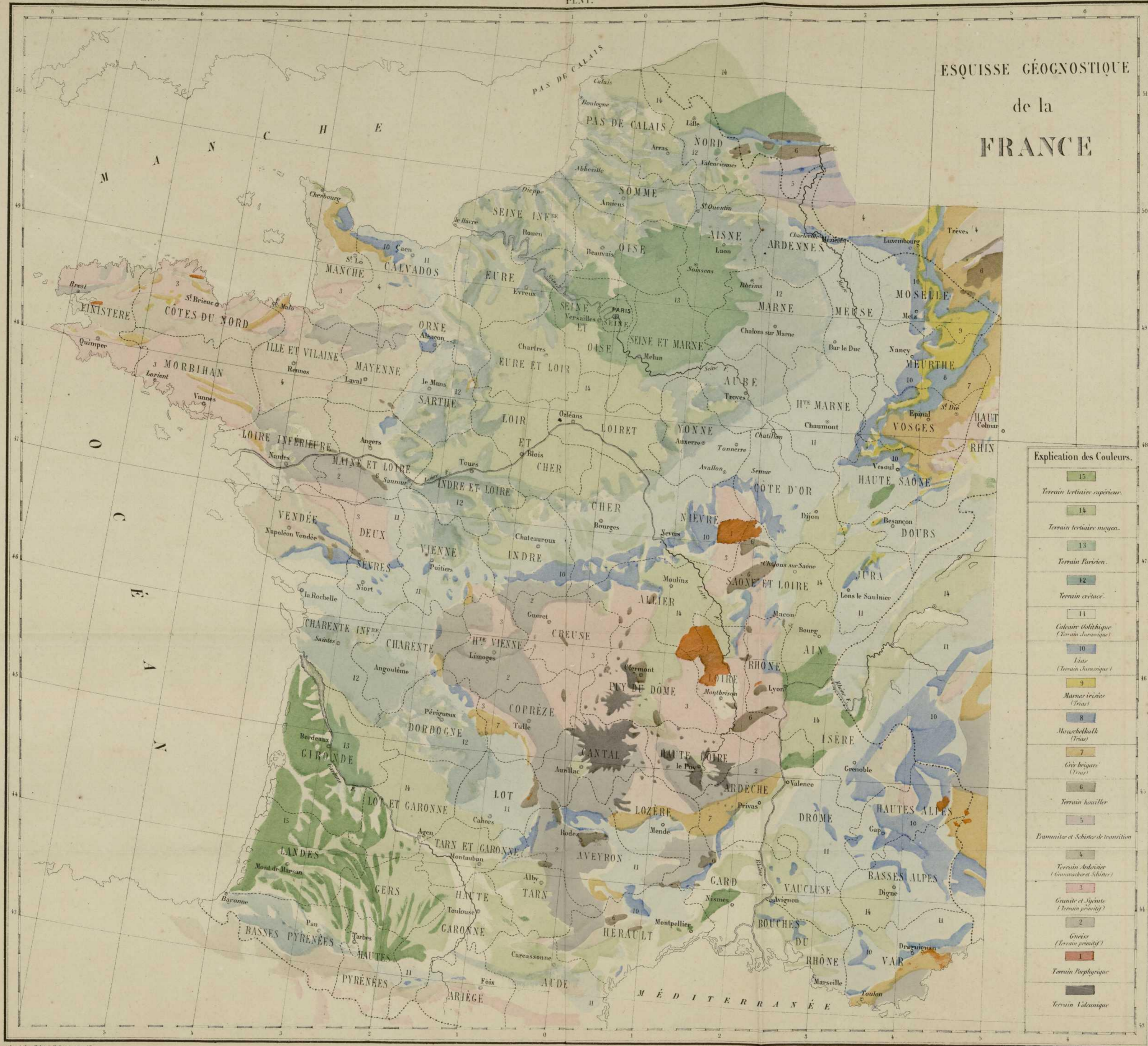
ESQUISSE GÉOGNOSTIQUE de la BELGIQUE



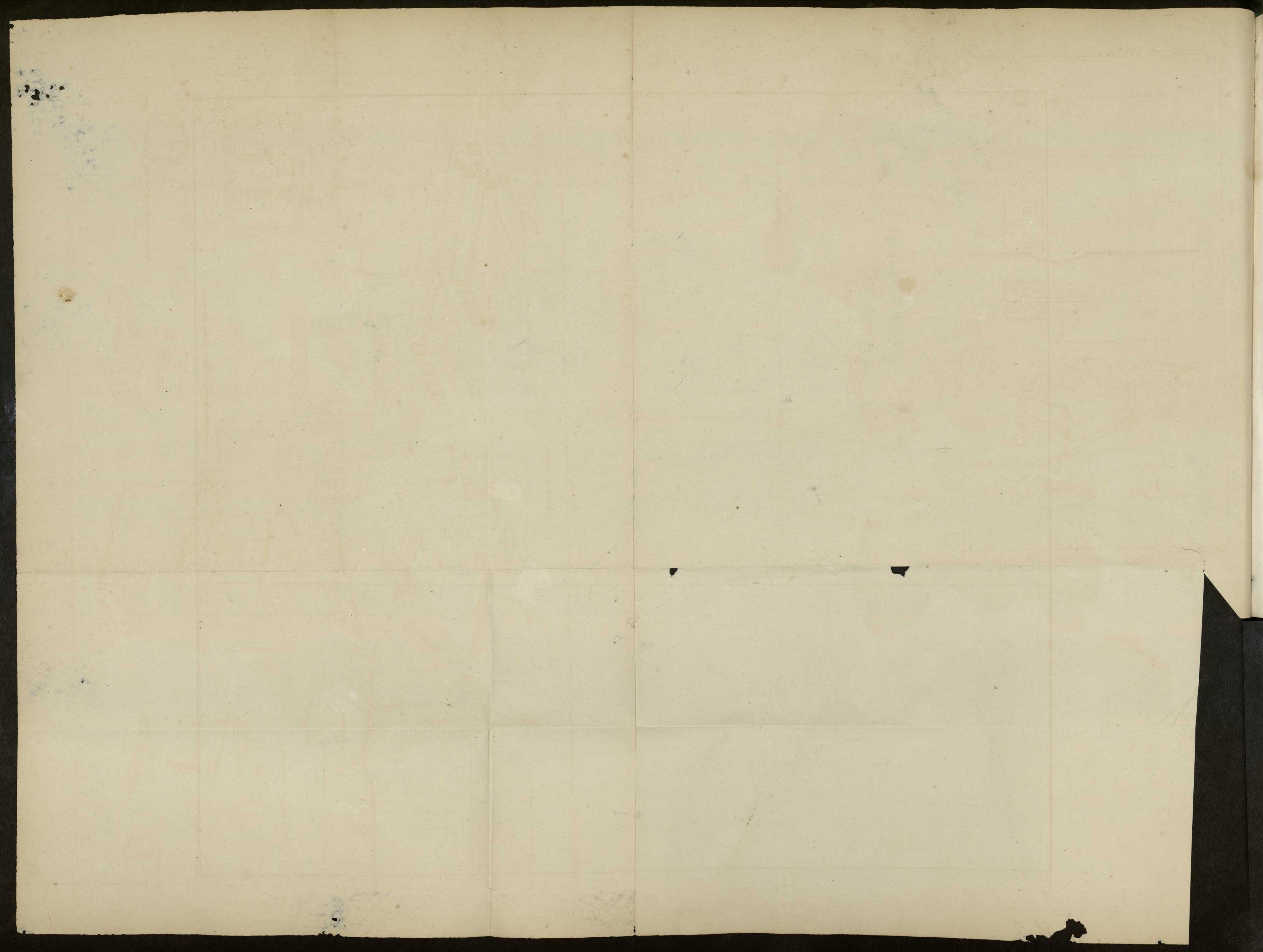




# ESQUISSE GÉOGNOSTIQUE de la FRANCE









FABRICATION DES BRIQUES.

Fig. 161. Moulin à corroyer la terre.

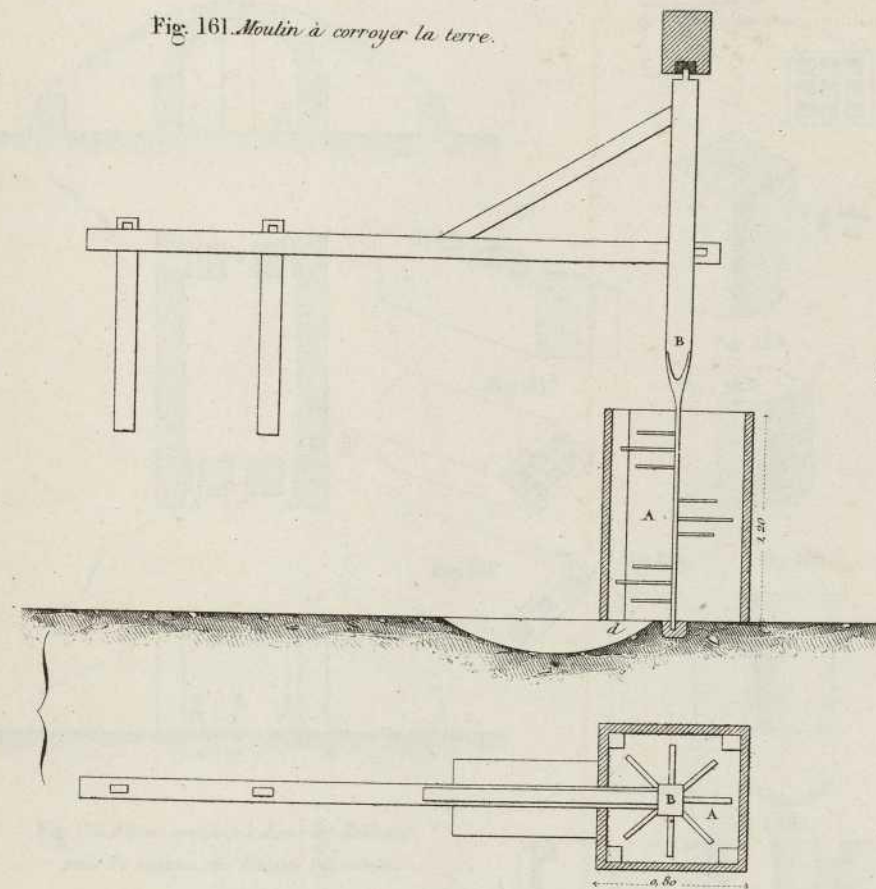


Fig. 165. Banc de moulage du briquetier Anglais.

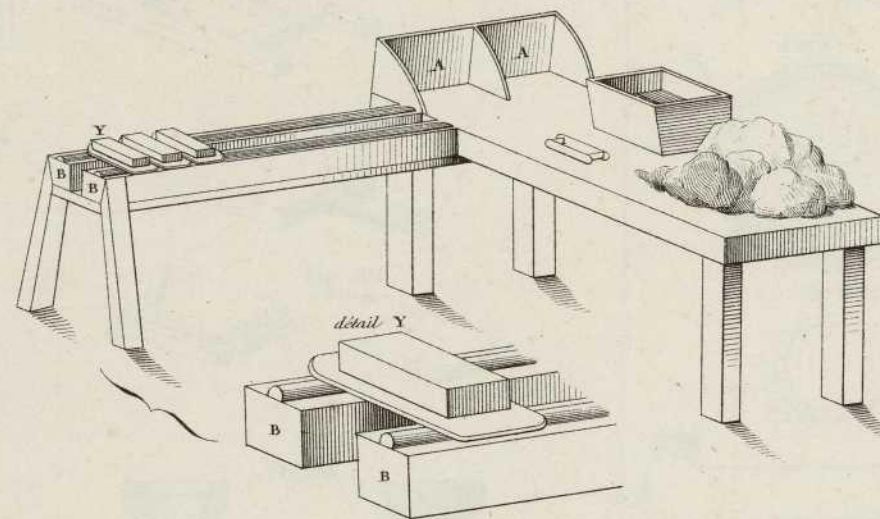


Fig. 173. Arrangement des six premiers lits de briques pour la cuisson en tas.

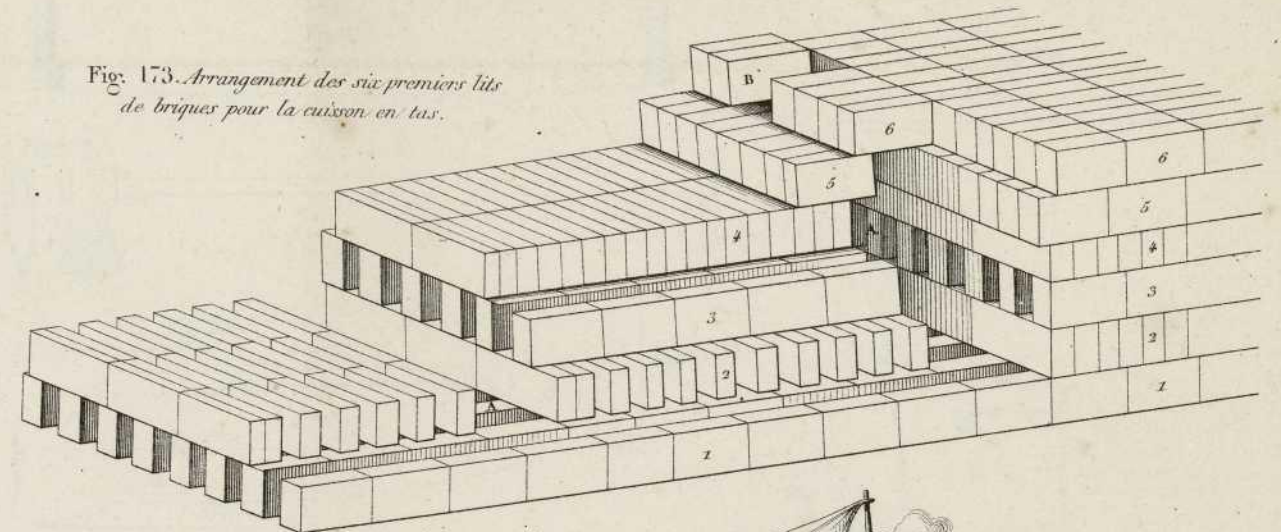


Fig. 162. Table de moulage du briquetier Belge.

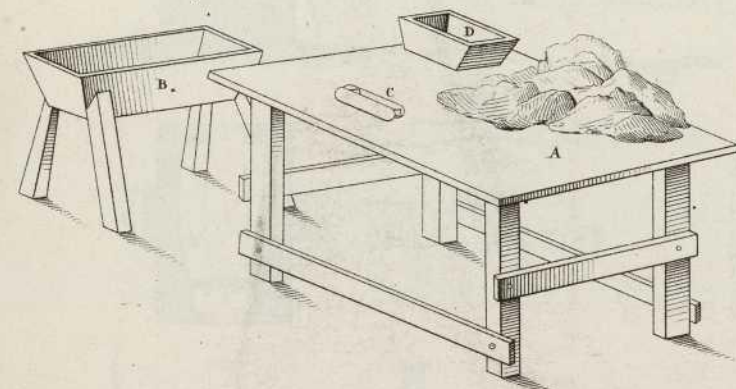


Fig. 166.

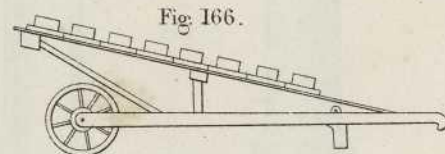


Fig. 167.



Fig. 171.

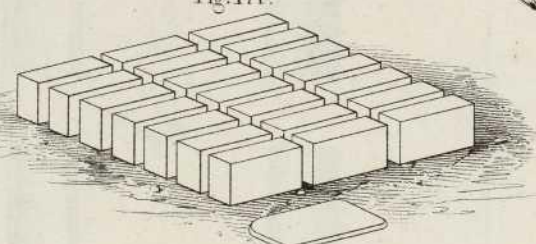


Fig. 168.



Fig. 169.

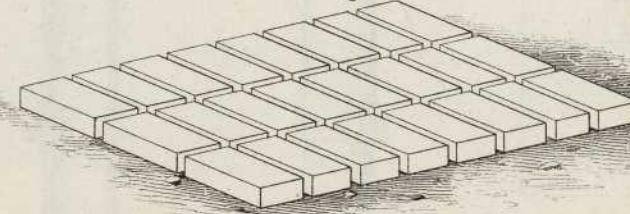


Fig. 170.

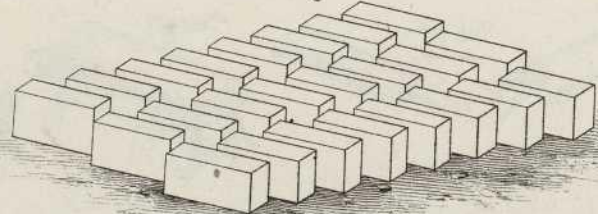


Fig. 175. Four de Rupelmonde.

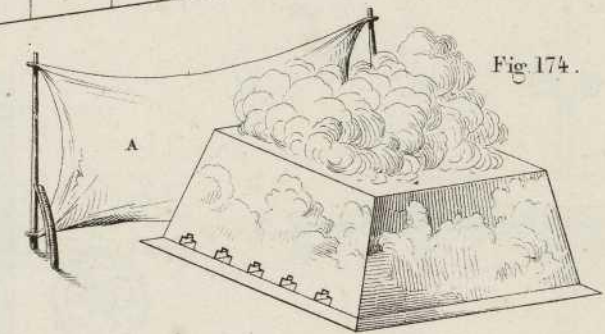
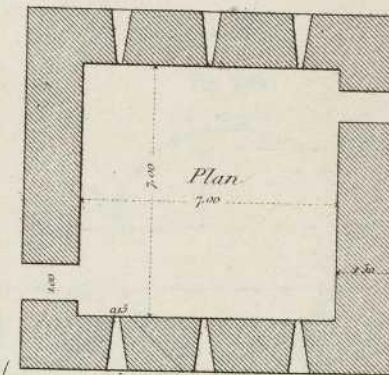


Fig. 176. Four de Hemixen.

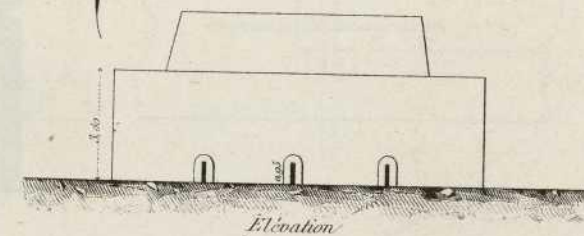
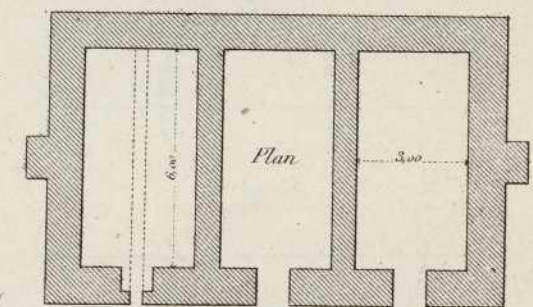
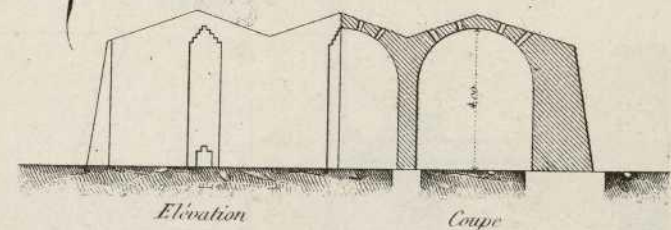
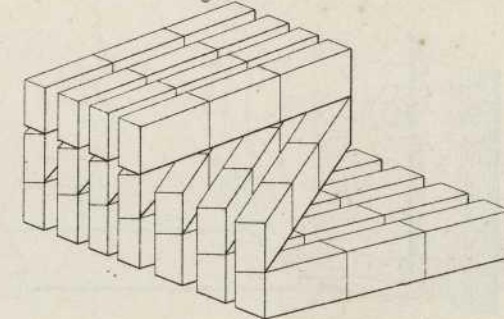


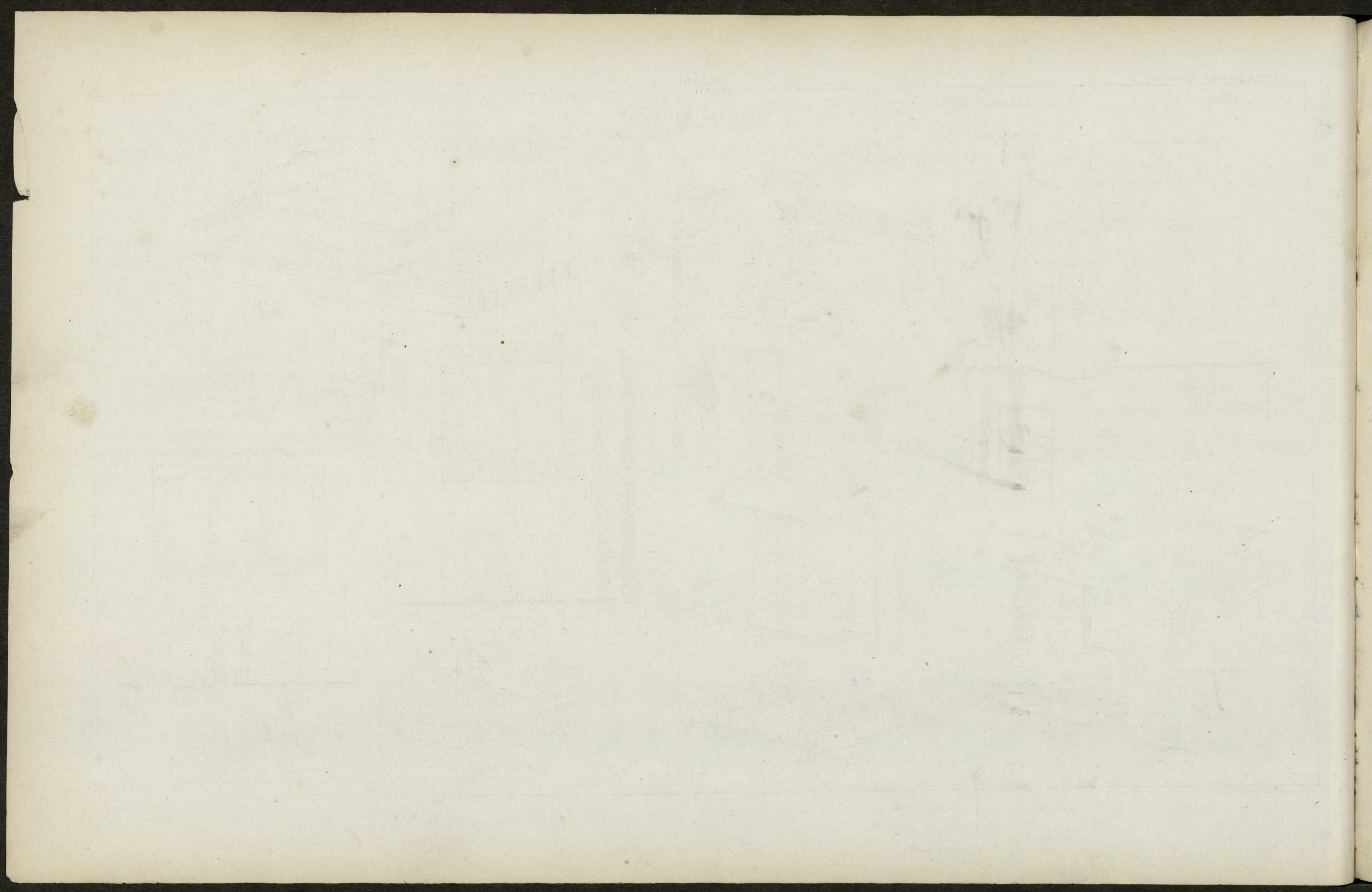
Fig. 172.



Echelle des Fig. 175 et 176, 0,005 p<sup>r</sup> 1 Mètre.

Echelle de la Fig. 170, 0,002 p<sup>r</sup> 1 Décimètre.

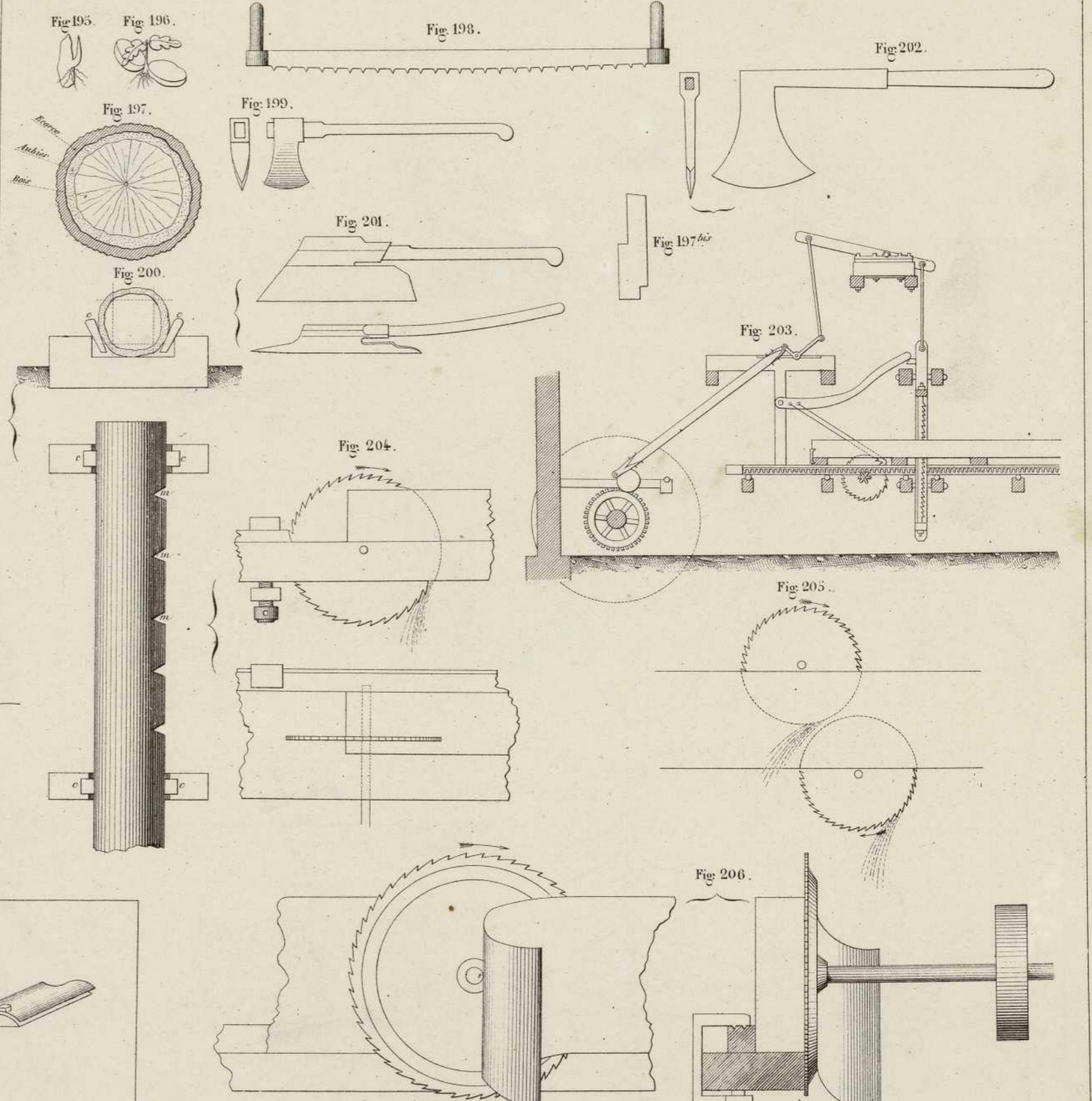
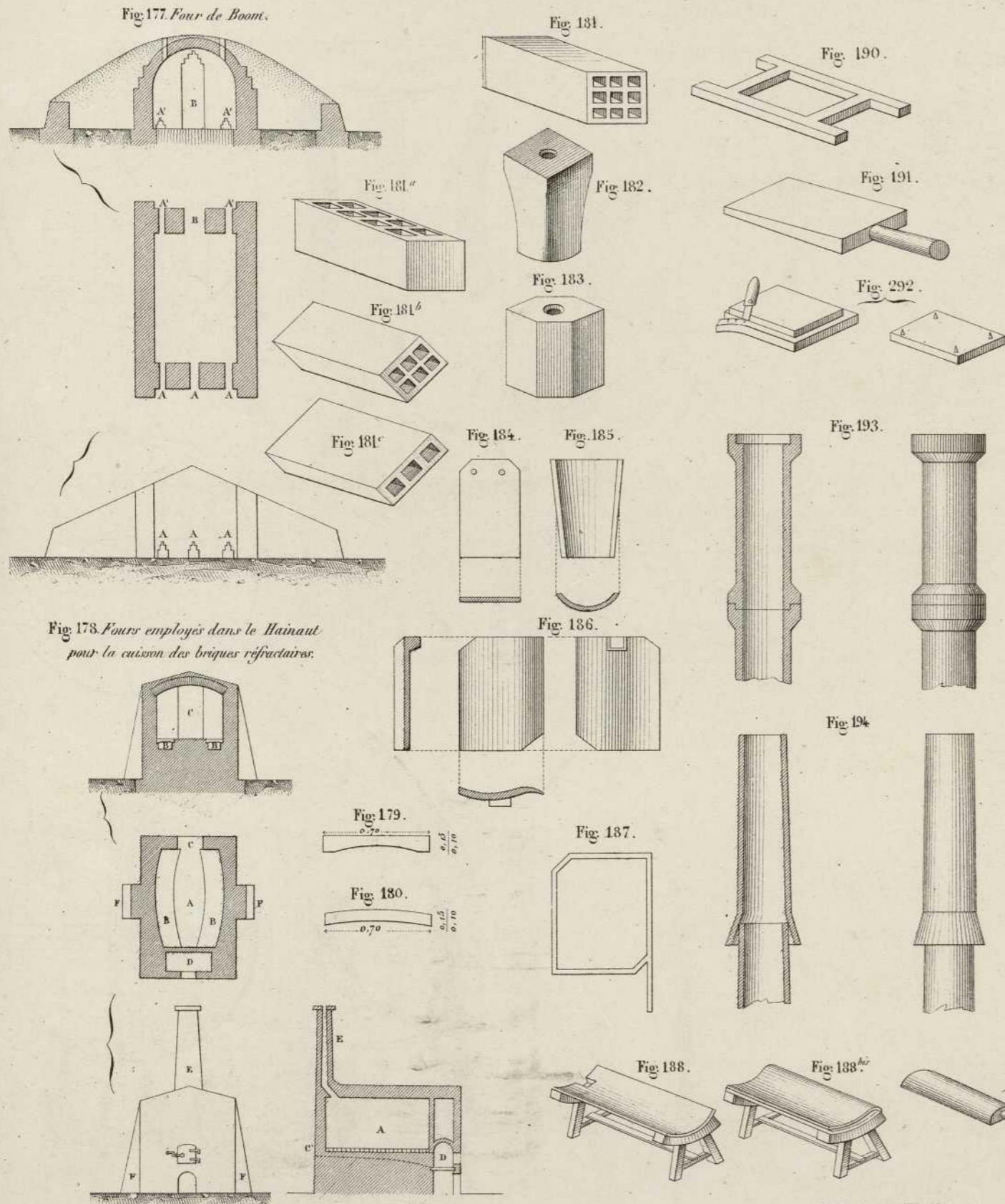






MATÉRIAUX EN TERRE CUITE.

MATÉRIAUX LIGNEUX

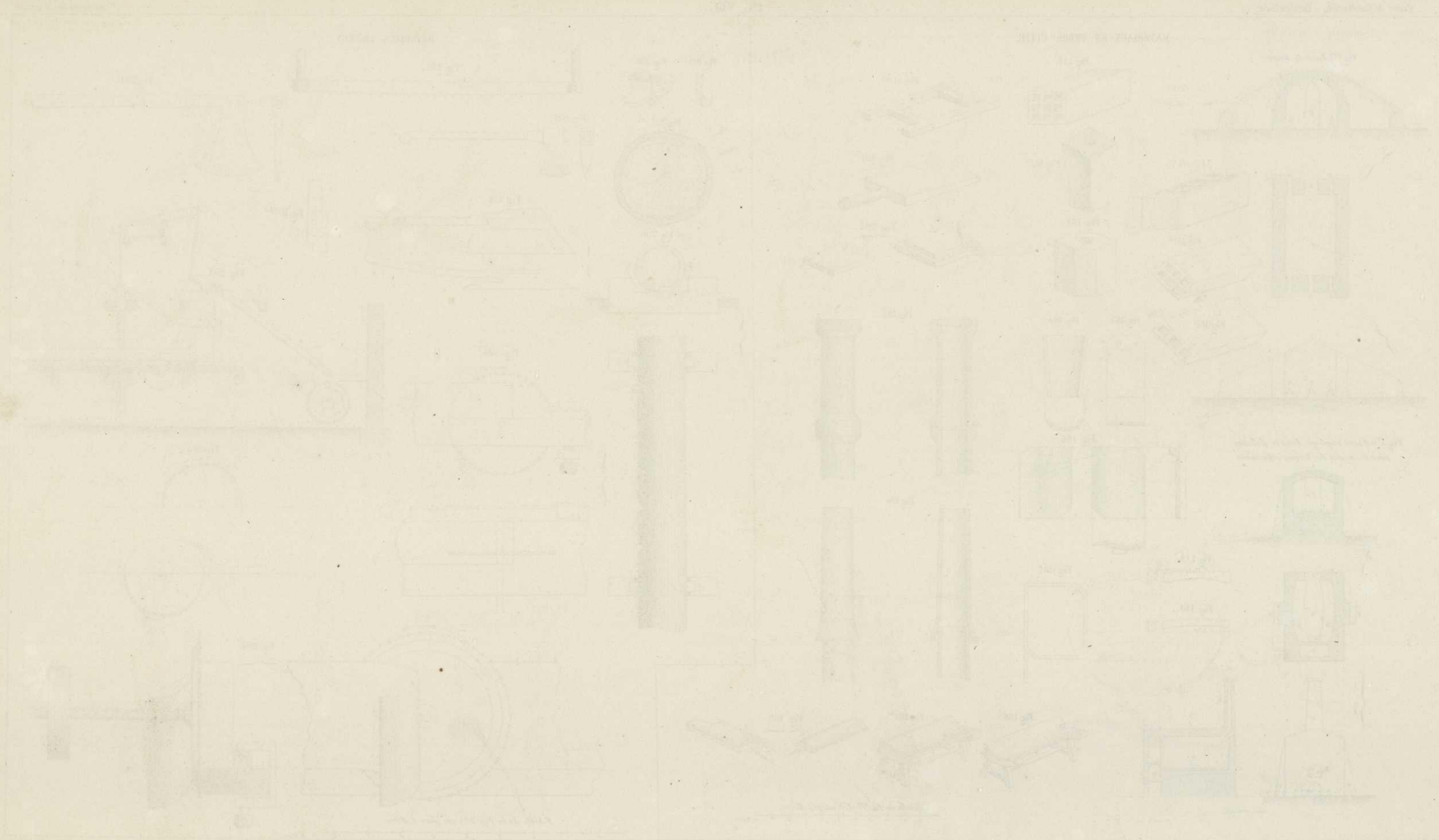


Echelle des Fig. 177 et 180 à 189 pour 1 Mètre.

Echelle de la Fig. 203 à 206 pour 1 Mètre.

Gravé par Erhard R. Bonaparte 42.







MATÉRIAUX LIGNEUX.

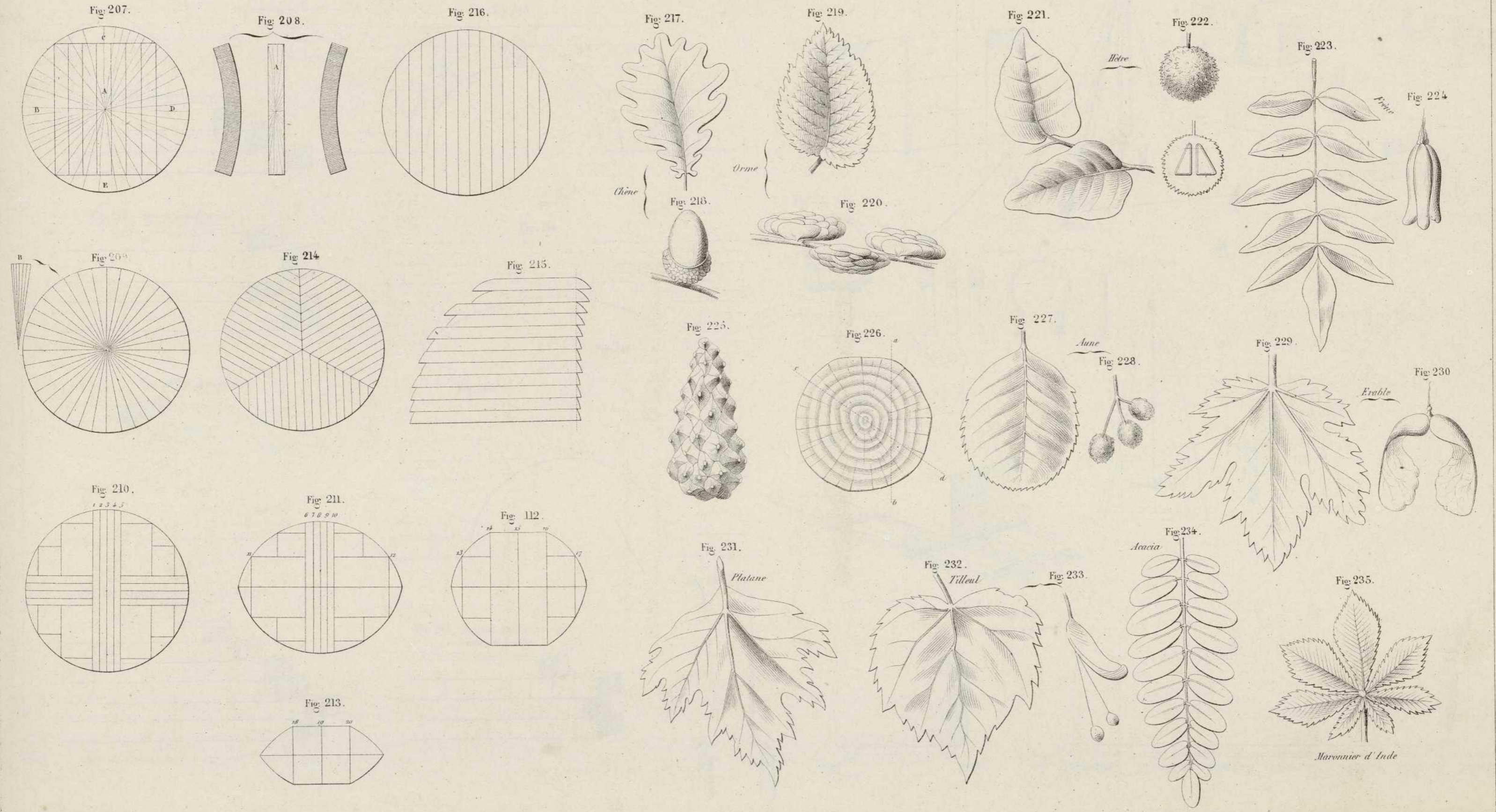
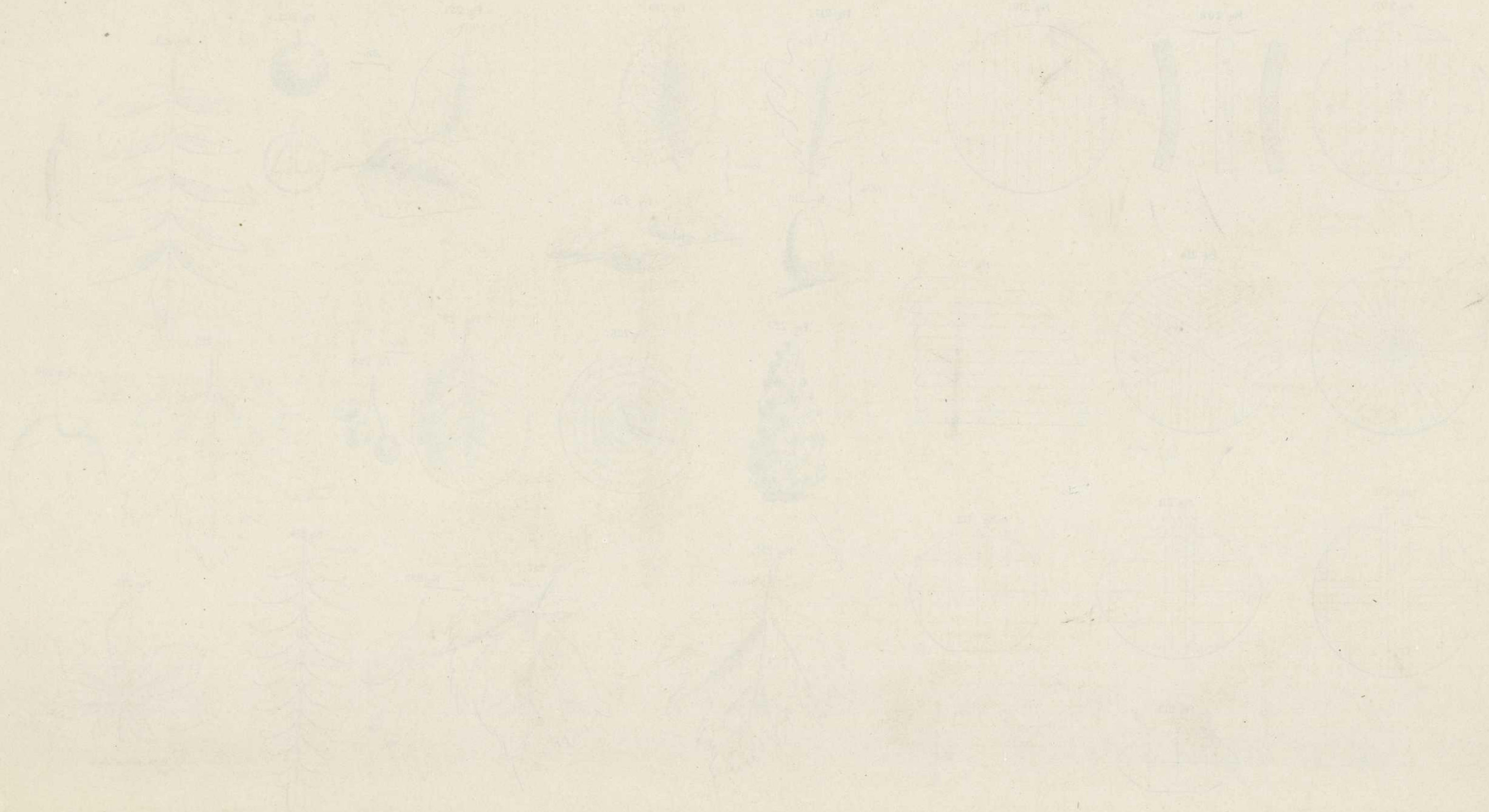




PLATE I





ART DU MAÇON APPAREILLEUR.

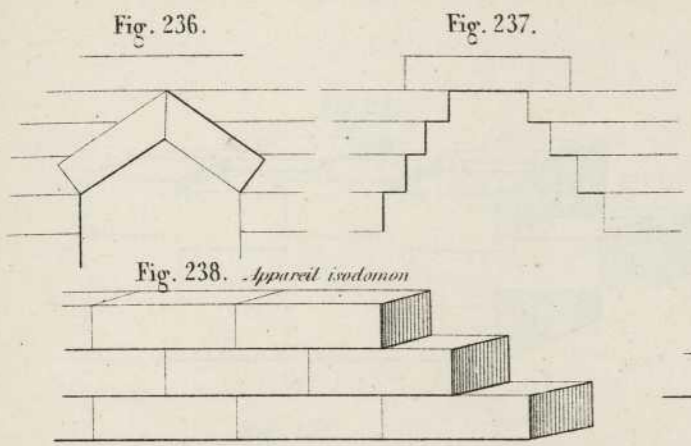


Fig. 236.

Fig. 237.

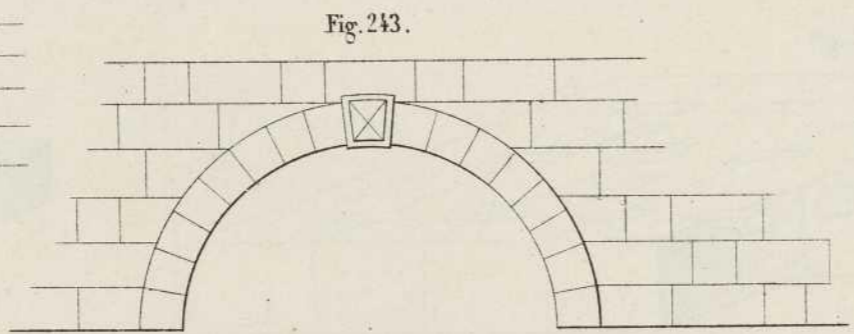


Fig. 243.

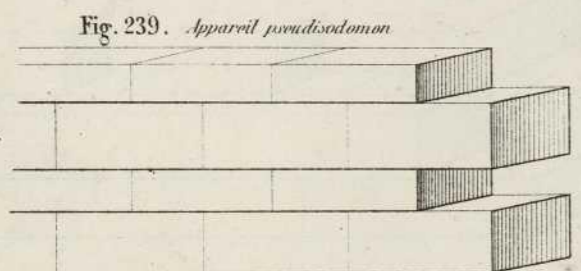


Fig. 238. Apparil isodomon

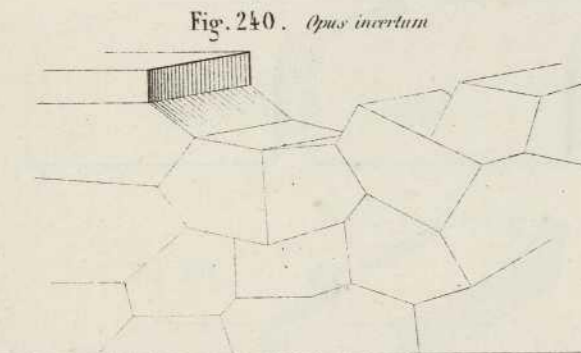


Fig. 239. Apparil pseudisodomon

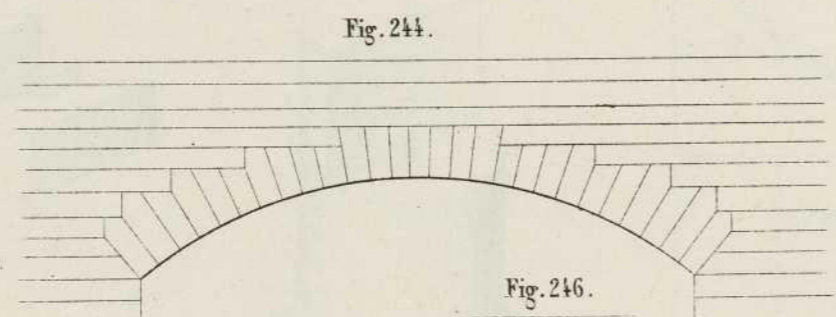


Fig. 244.

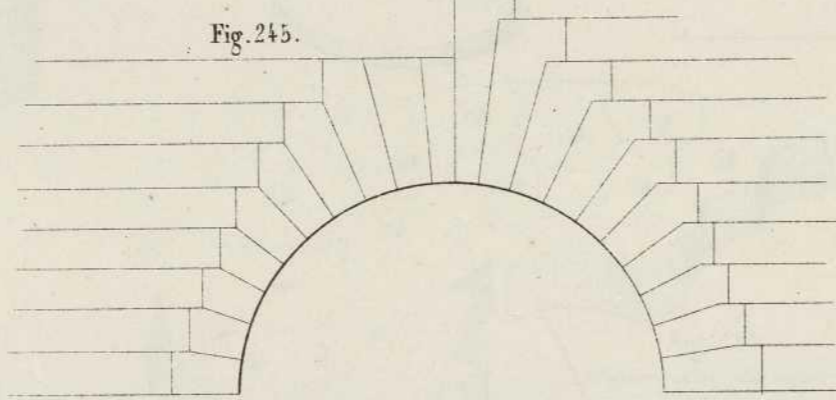


Fig. 245.

Fig. 246.

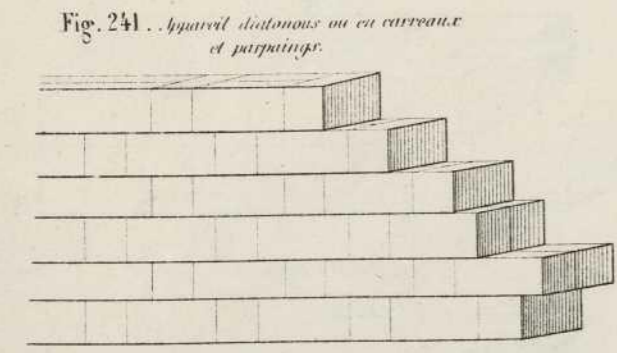


Fig. 241. Apparil diazonous ou en carreaux et piquetés.

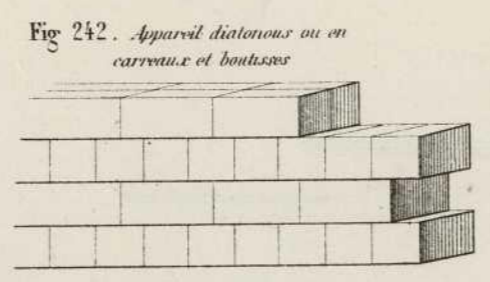


Fig. 242. Apparil diazonous ou en carreaux et boutisses

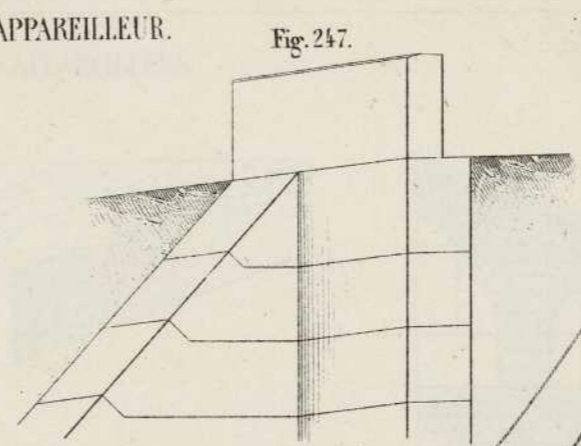


Fig. 247.

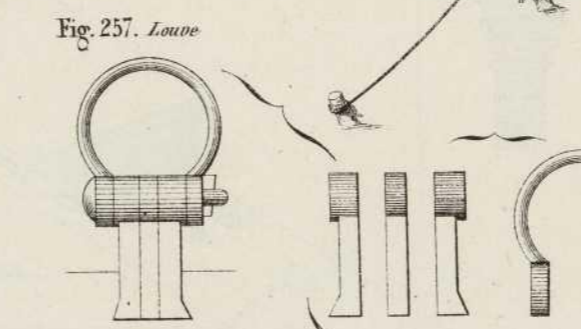


Fig. 257. Louve

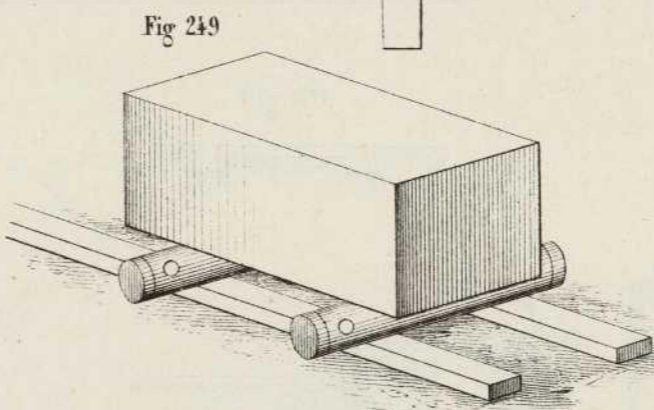


Fig. 249

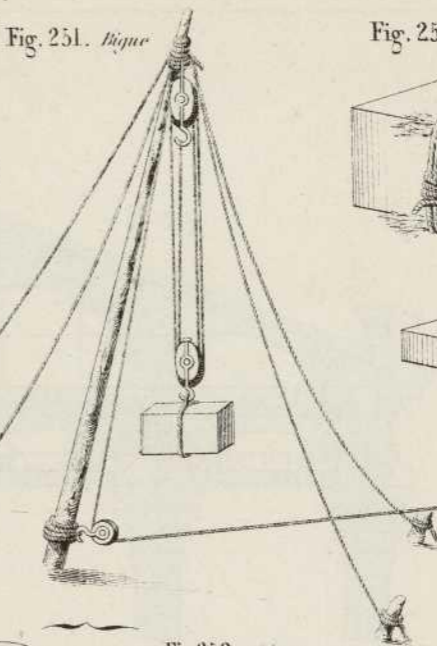


Fig. 251. Bique

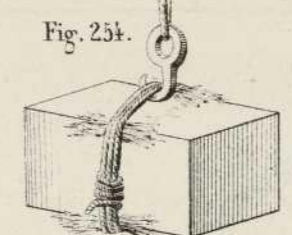


Fig. 254.

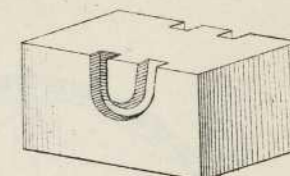


Fig. 255.

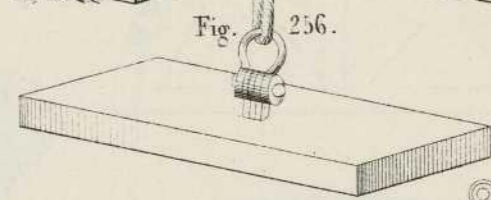


Fig. 256.

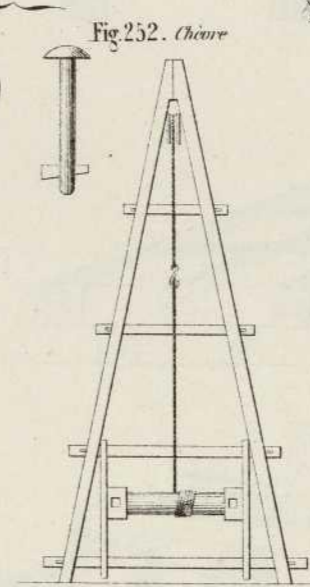


Fig. 252. Chevre

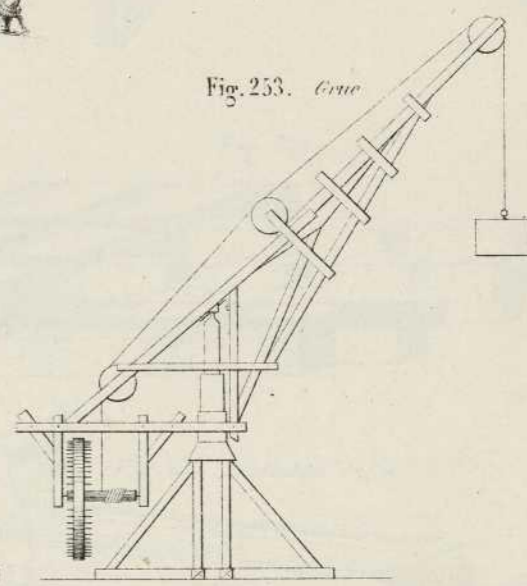


Fig. 253. Crue

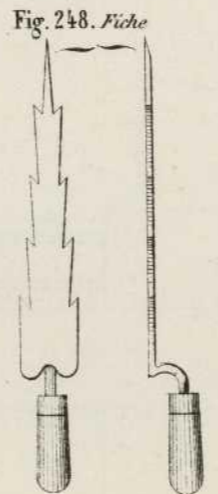


Fig. 248. Fiche

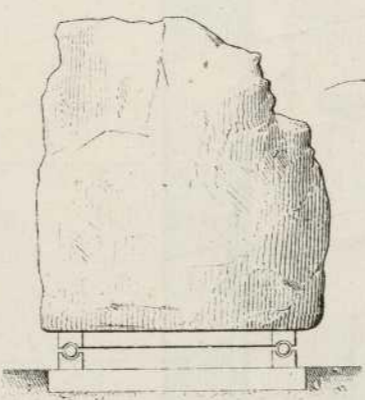
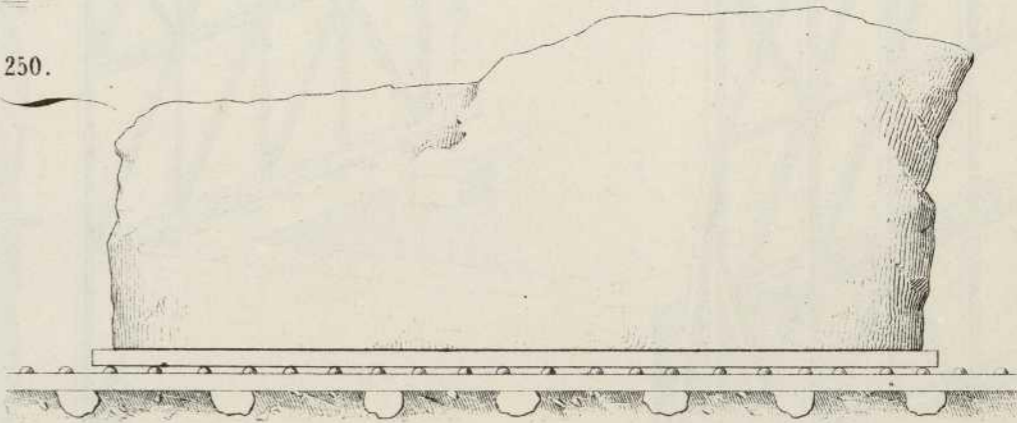


Fig. 250.









ART DU MAÇON APPAREILLEUR.

Fig. 258.

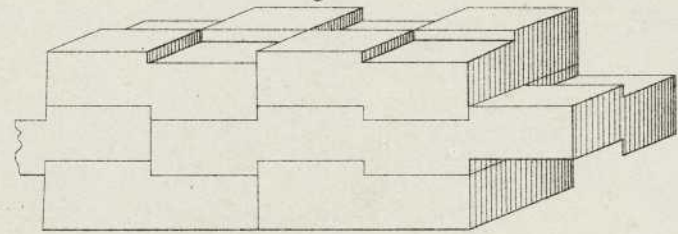


Fig. 259.

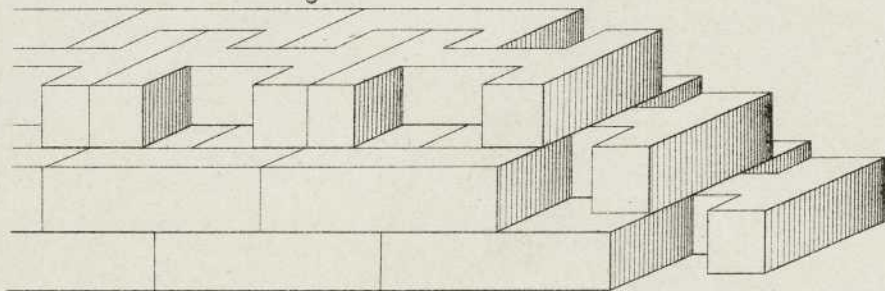


Fig. 260.

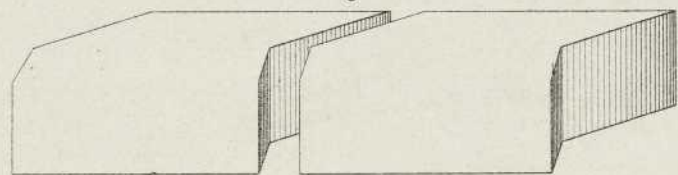


Fig. 261.

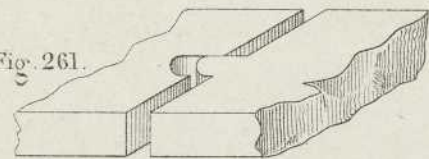


Fig. 262.

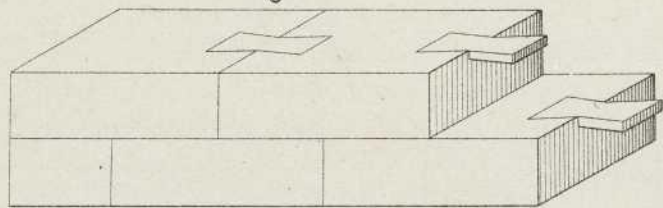


Fig. 263.

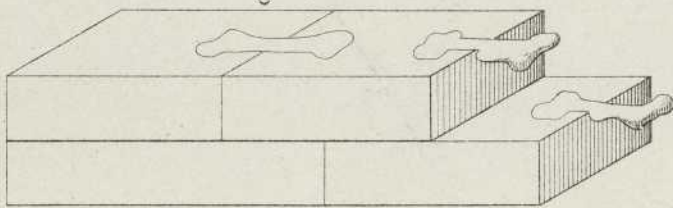


Fig. 264.

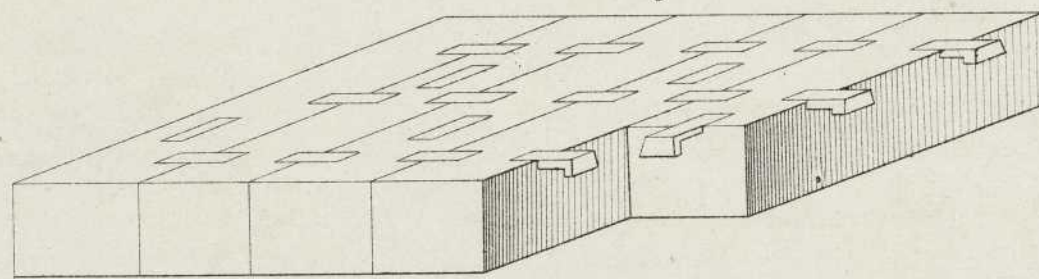


Fig. 265.

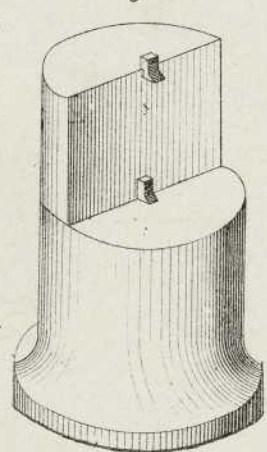


Fig. 266.

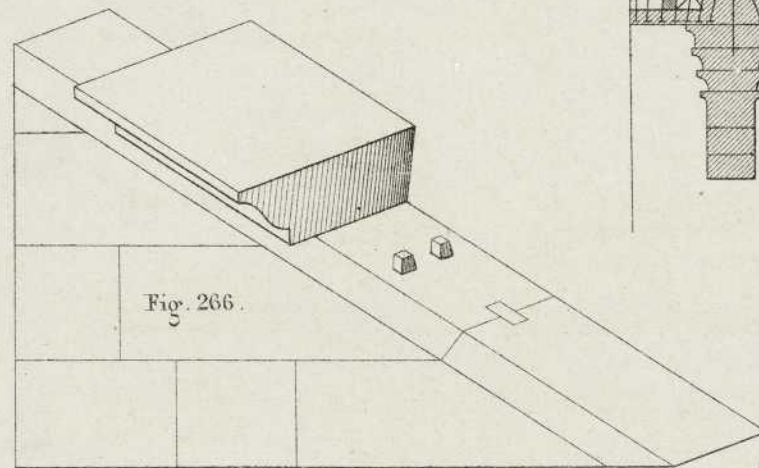


Fig. 271.

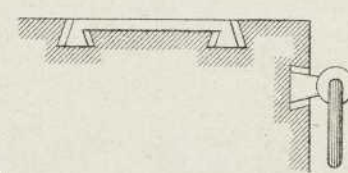


Fig. 267.

Fragment d'une des assises du phare d'Eddystone.

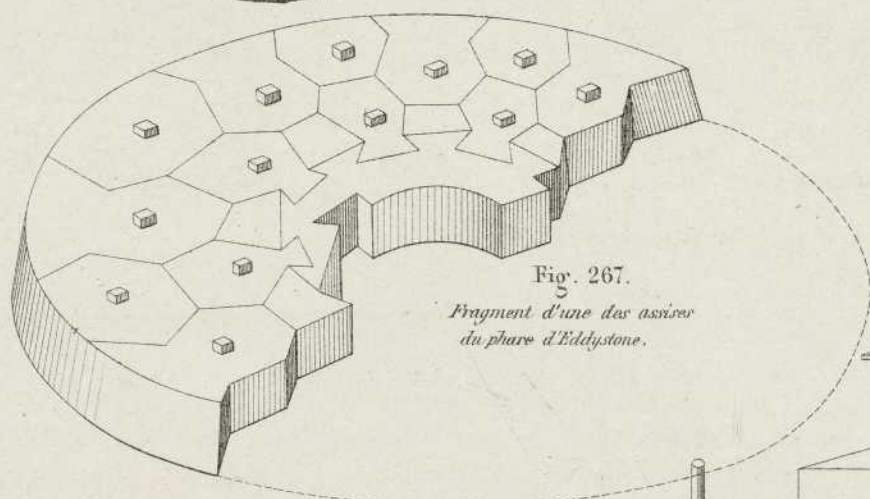


Fig. 268.

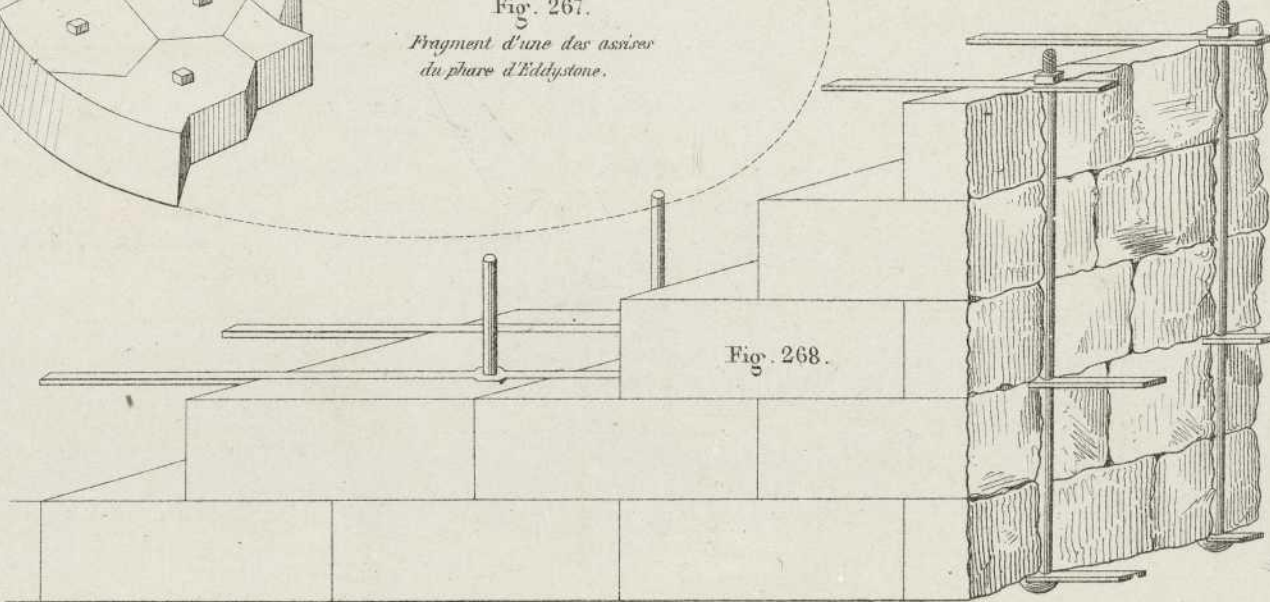


Fig. 269.

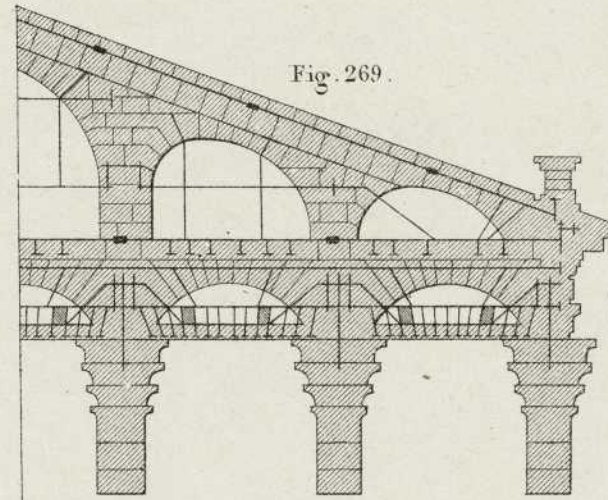


Fig. 273.

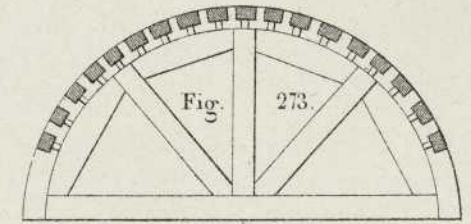


Fig. 274.

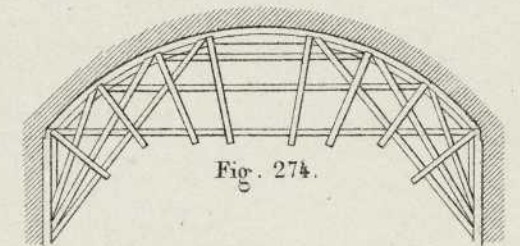


Fig. 270.

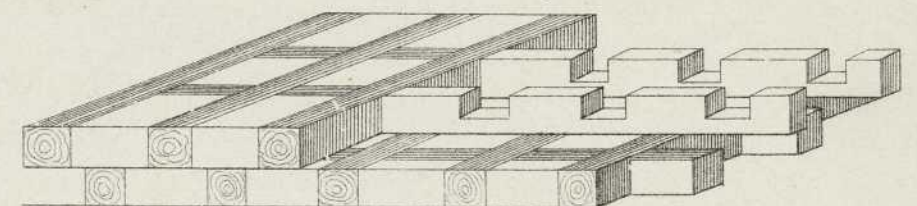
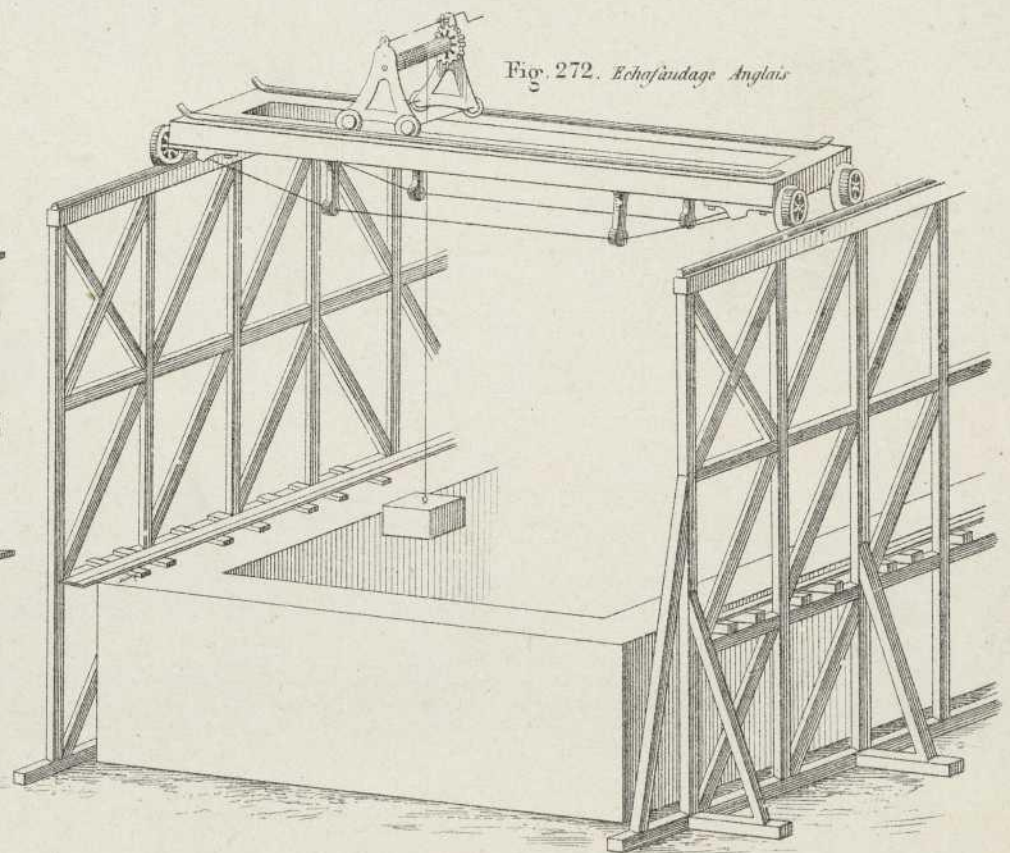
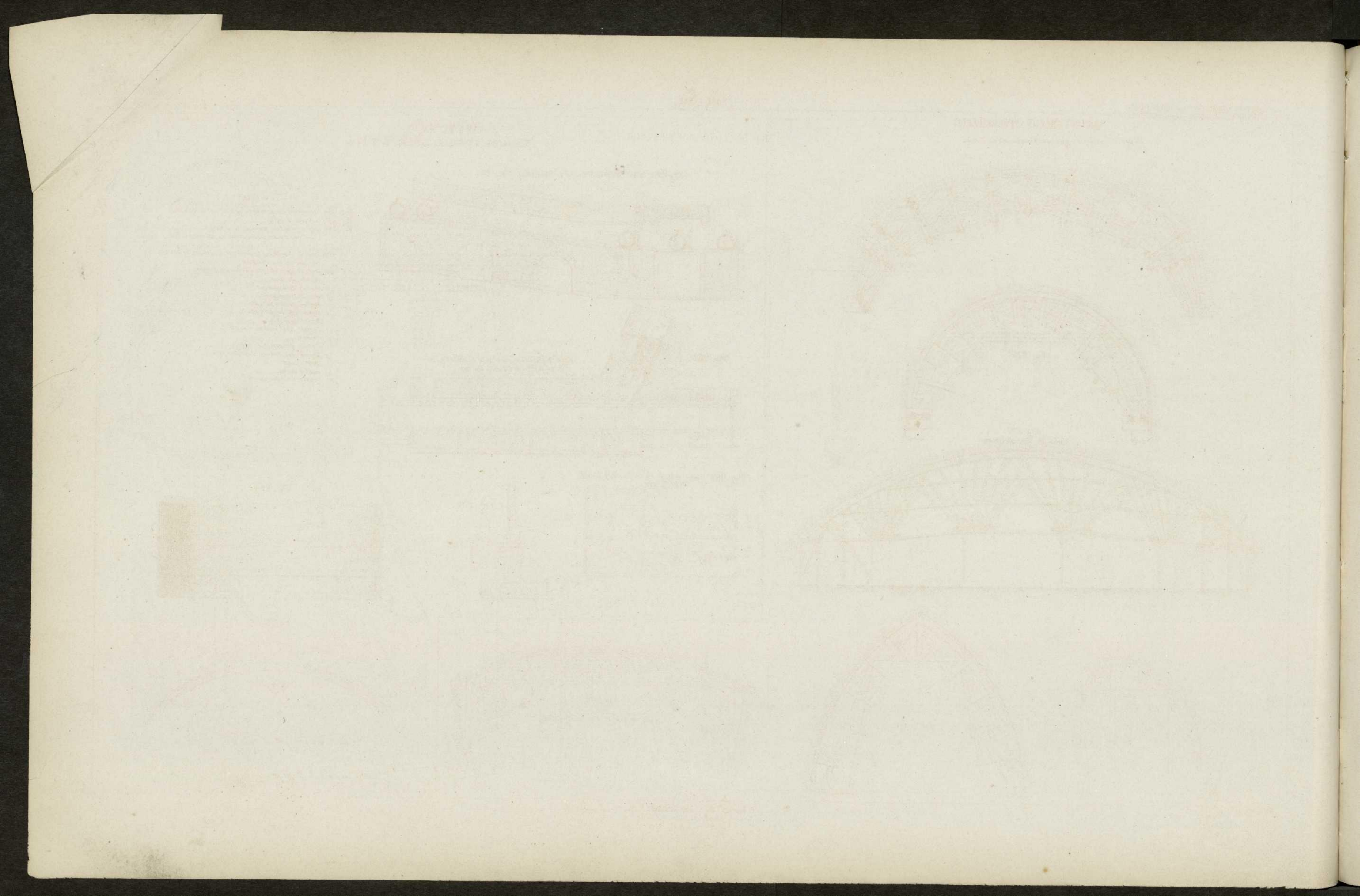


Fig. 272. Echafaudage Anglais.









ART DU MAÇON APPAREILLEUR

Fig. 275. Centre du Pont de Waterloo sur la Tamise

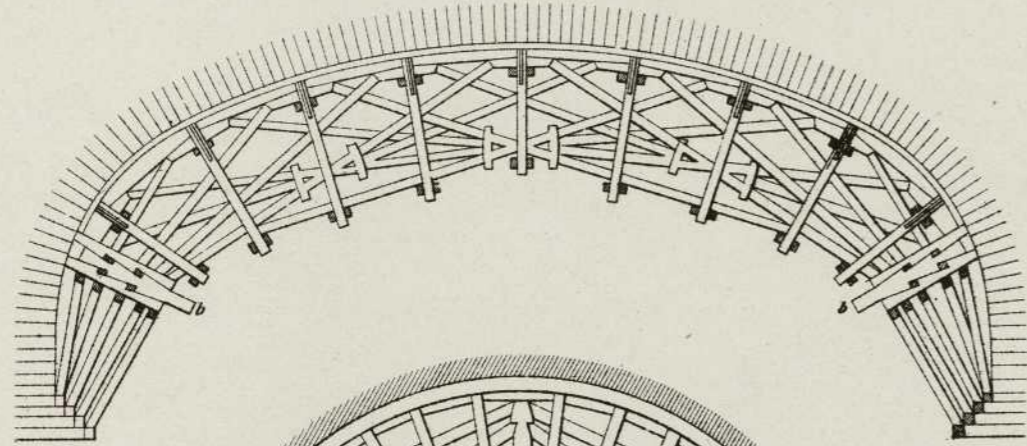


Fig. 276.

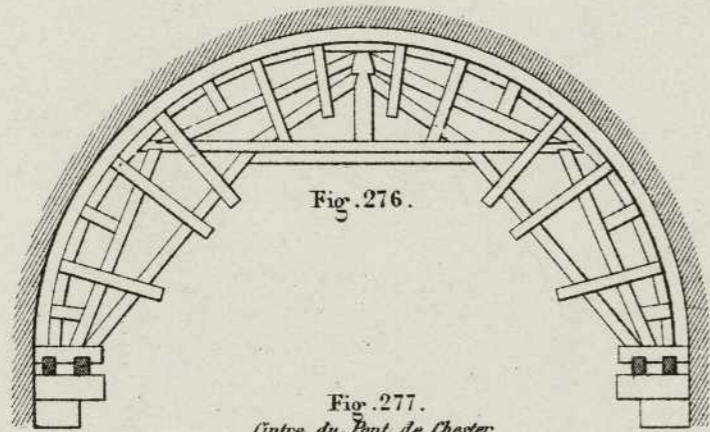


Fig. 277. Centre du Pont de Chester

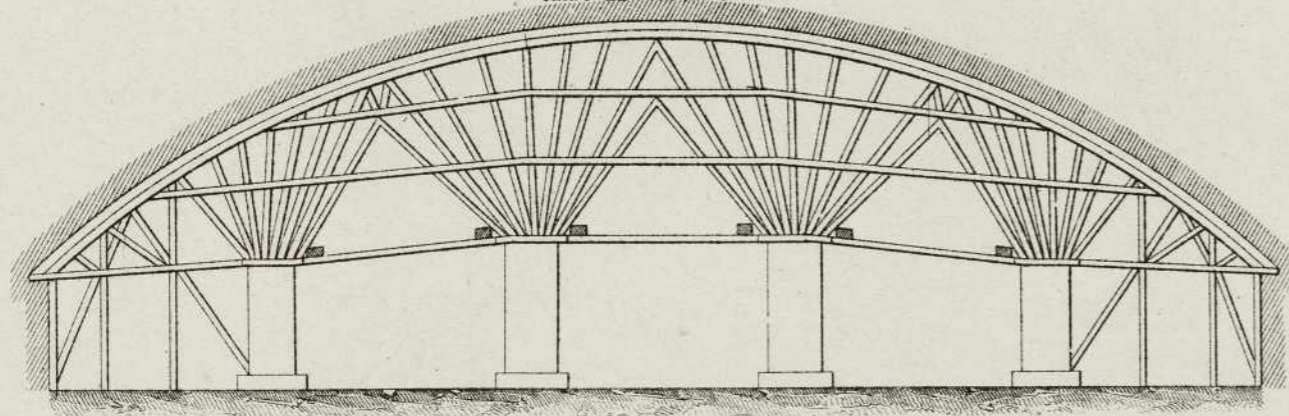


Fig. 278.

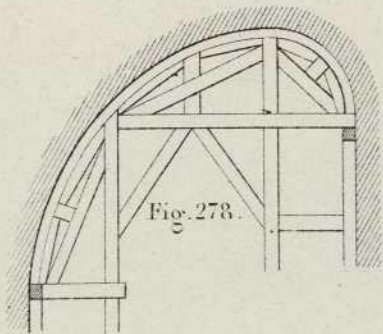
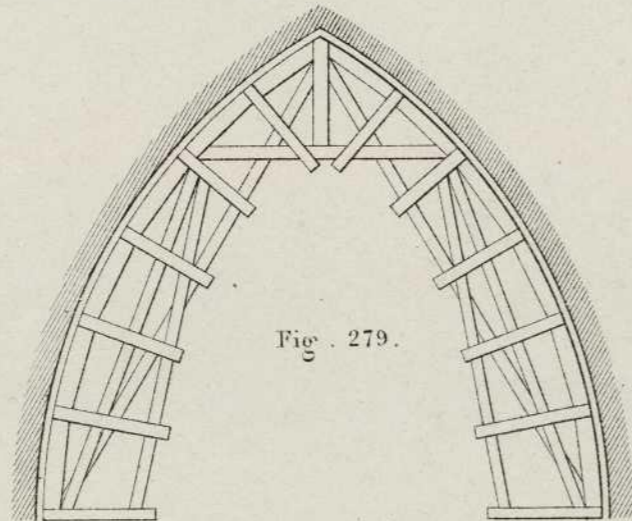


Fig. 279.



ART DU MAÇON  
Nouveau four à pouzzolane artificielle de M. Vicat.

Fig. 281. Coupe verticale prise sur la ligne CD de la Fig. 282.

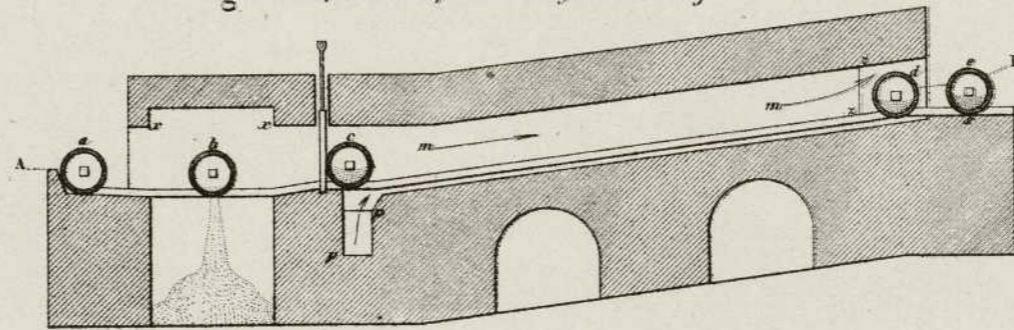


Fig. 282.

Coupe horizontale prise à la hauteur A. B. de la Fig. 281 et EF de la Fig. 285.

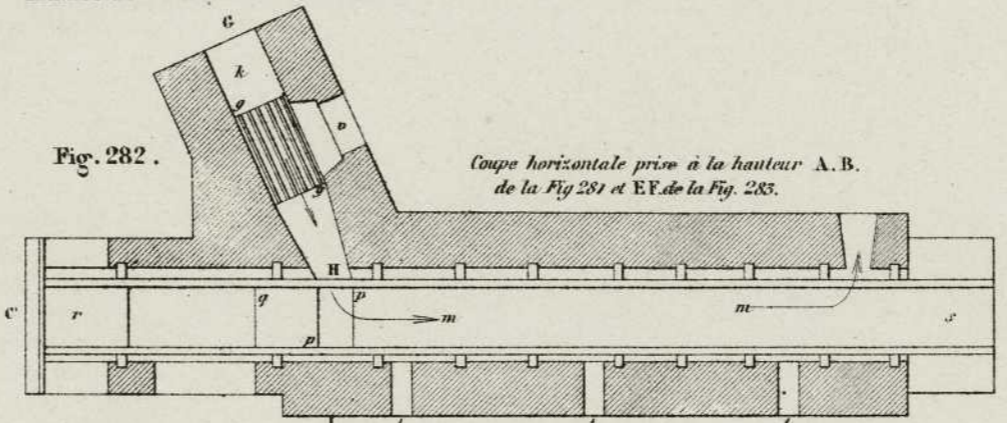


Fig. 283. Coupe verticale prise sur la ligne GHI de la Fig. 282.

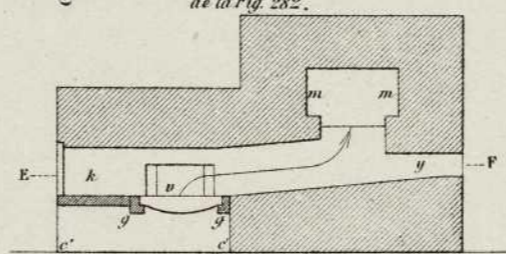


Fig. 286.

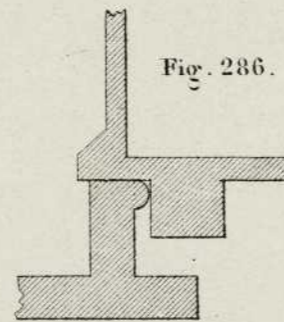


Fig. 284.

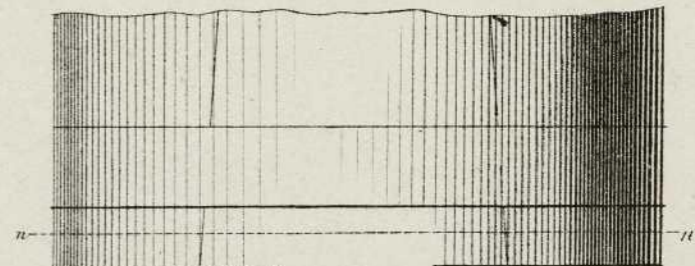
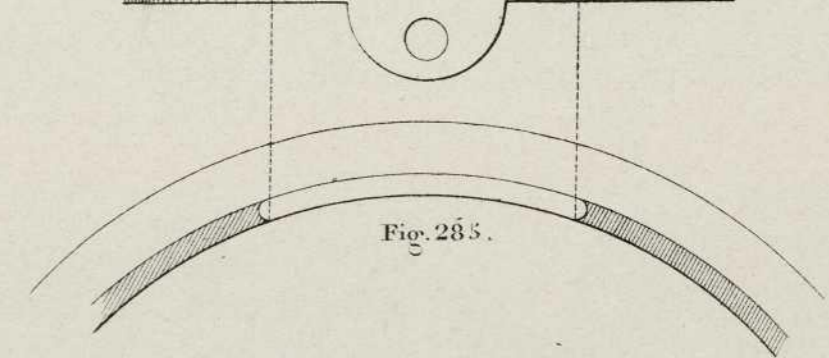


Fig. 285.



Echelle des Fig. 281, 282, et 283.



Echelle des Fig. 284, 285 et 286.

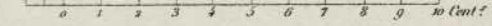
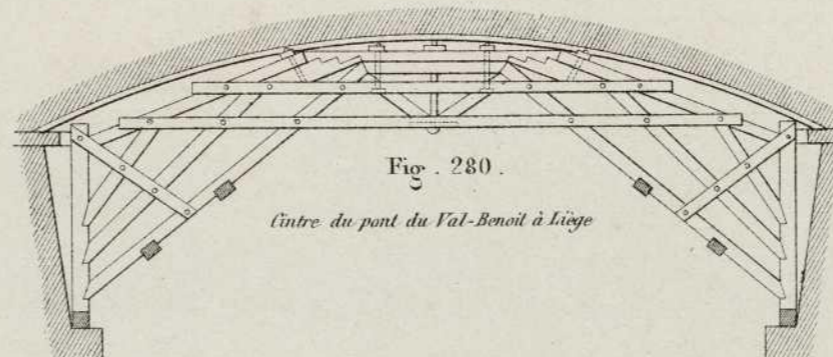


Fig. 280.

Centre du pont du Val-Benoit à Liège



LÉGENDE

- Fig. 281. Vue extérieure de la partie du cylindre par où s'introduit
- Fig. 285. la douille à oculaire
- Fig. 286. Coupe transversale intérieure sur n n
- Fig. 288. Coupe sur l'axe du cylindre partie qui repose sur le rail

- m m Canal de chauffe p p conduit par où arrivent les gaz brûlés z z
- issus par où ils s'échappent
- g g Grille du foyer q q réceptacle des pouzzolanes
- a a Cylindre déchargé
- b b idem en chargement
- c c idem en chargement
- d d Deuxième cylindre de la file
- e e Premier cylindre de la file
- o o Regard sur la grille
- t t t Regard sur le canal de chauffe
- c c c Coudrier
- k k Porte de chargement de la grille
- y y Regard pour débayer le canal inférieur
- r r Astet d'avant
- s s Astet d'après
- x x Chambre de déchargement

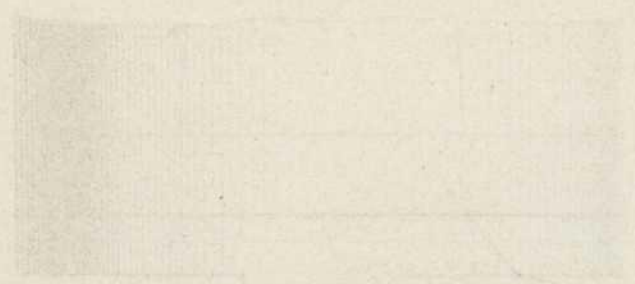


PL. 21

Section of the bridge

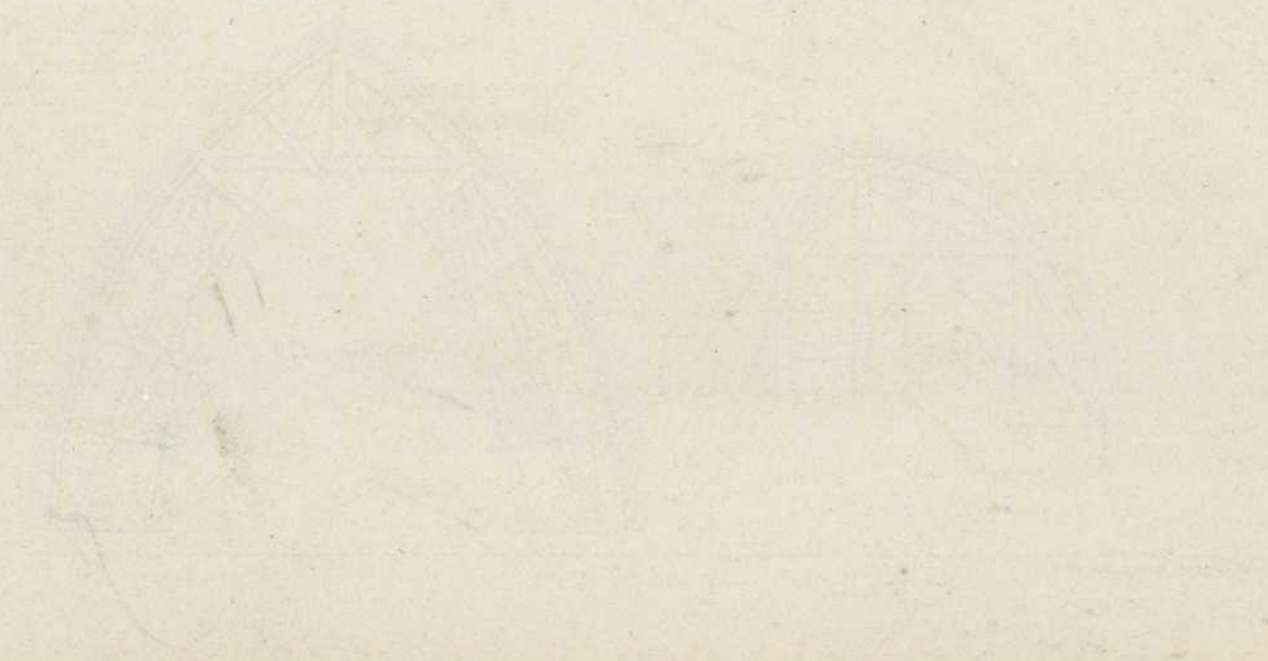
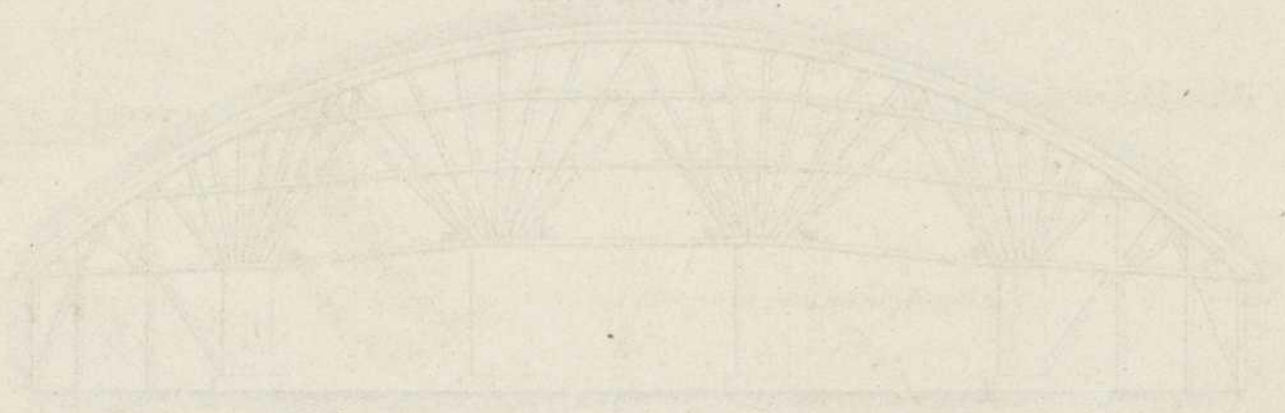
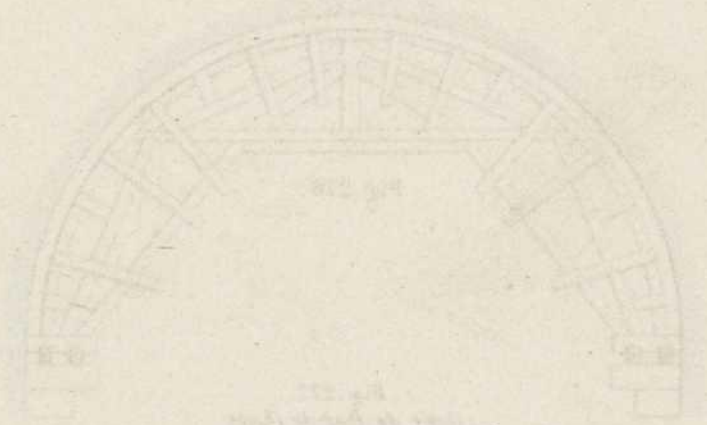


Vertical list of text annotations and labels on the left side of the page.



PL. 22

Section of the bridge





ART DU MAÇON.

Fabrication des Mortiers.

Maçonneries en Moellons

Fig. 287.

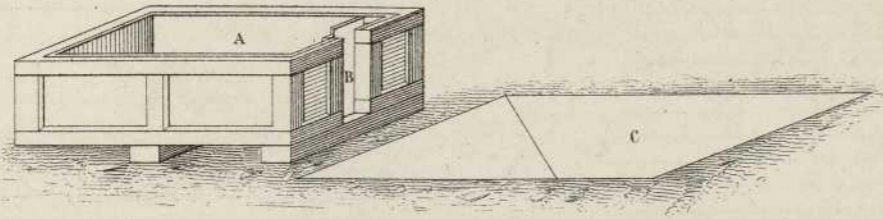


Fig. 288.

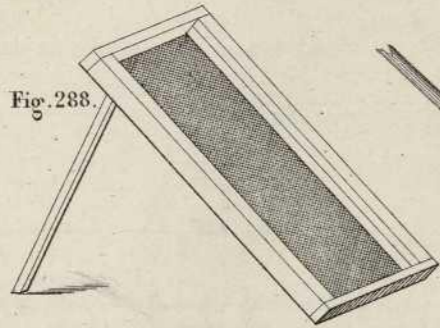


Fig. 289.

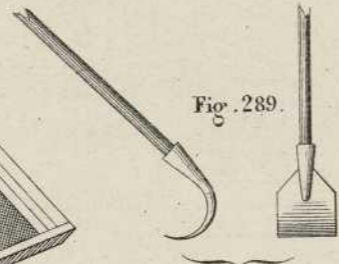


Fig. 291.

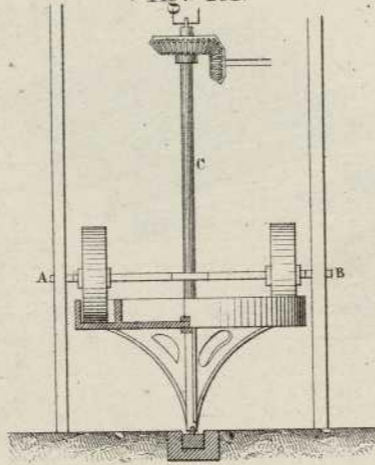


Fig. 292.

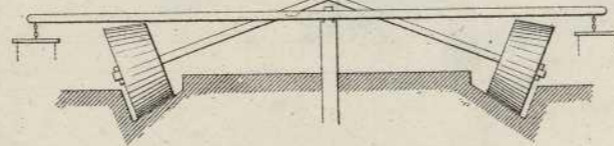


Fig. 293.

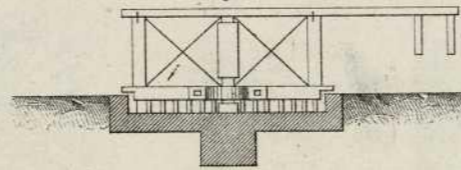


Fig. 290 bis

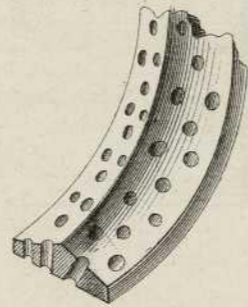
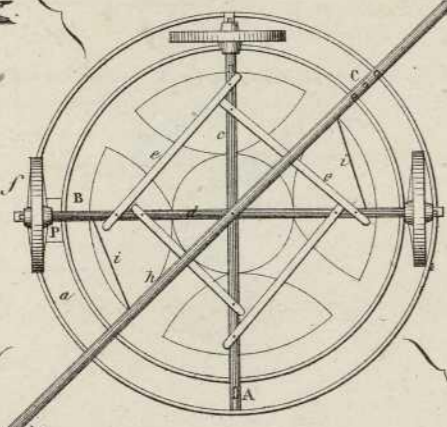
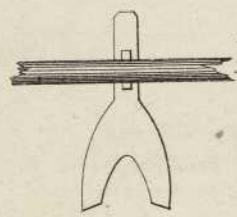


Fig. 290. Plan.



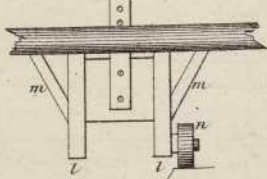
détail A.



détail B.



détail C.



Coupe

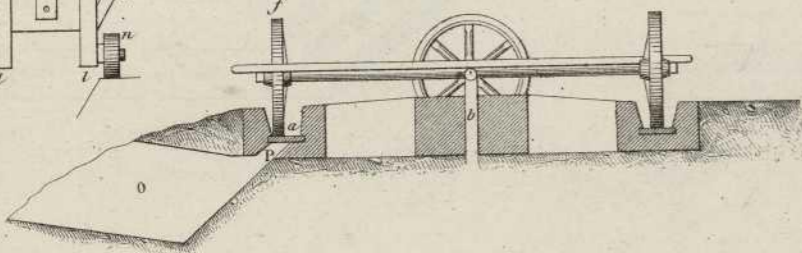


Fig. 294.

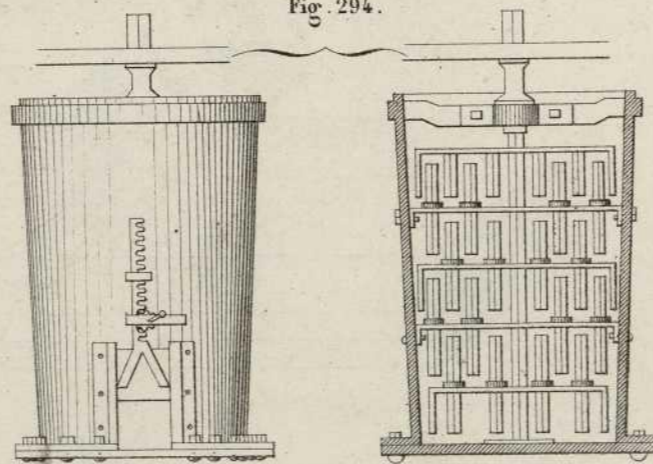


Fig. 295.

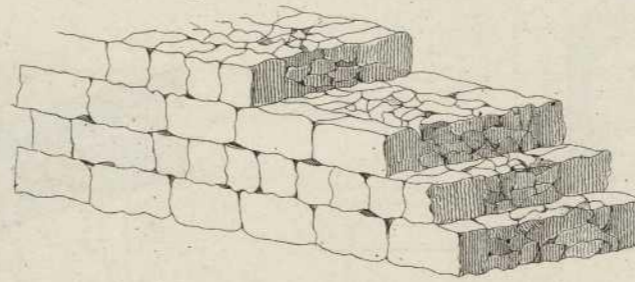


Fig. 296.

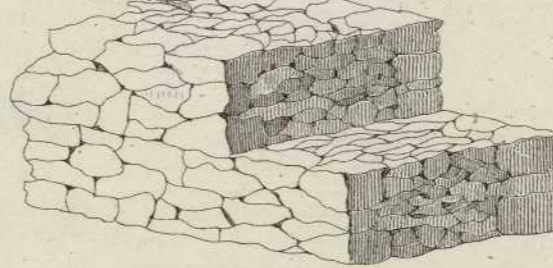


Fig. 297.

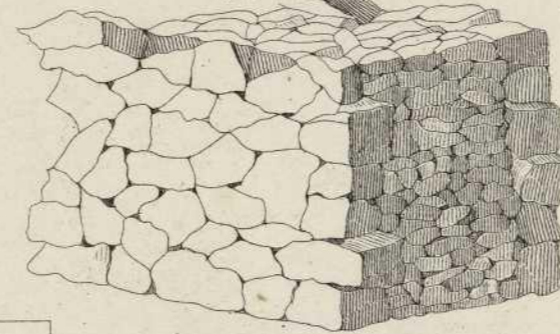


Fig. 298.

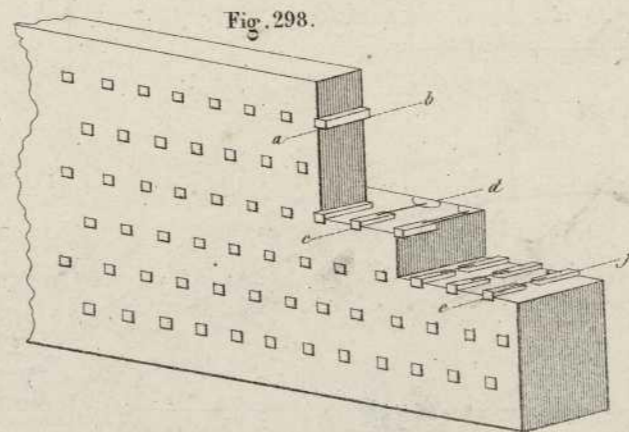
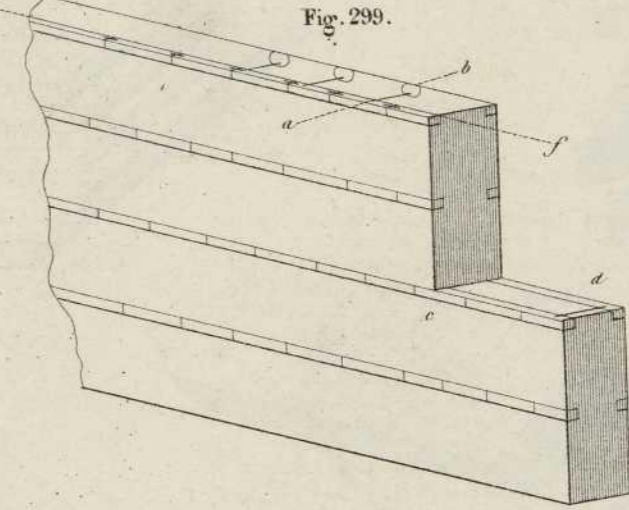
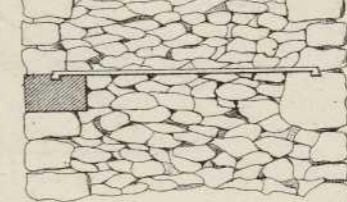


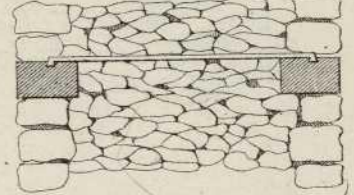
Fig. 299.



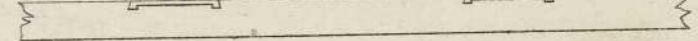
Coupe suivant a b.



Coupe suivant c d.



Coupe suivant e f.



Coupe suivant a b.



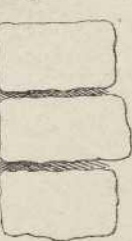
Coupe suivant c d.



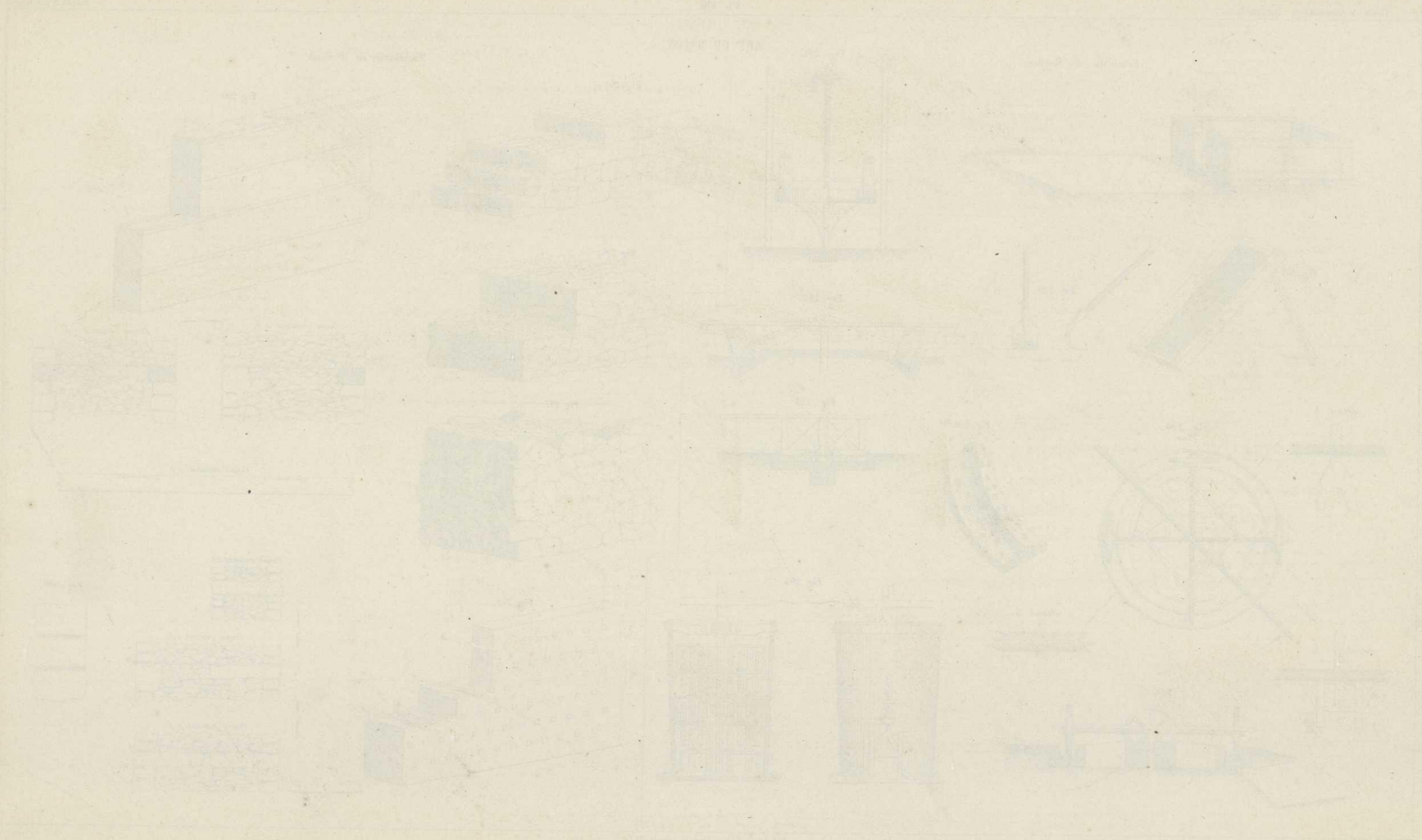
Coupe suivant e f.



Fig. 300.









ART DU MAÇON  
Maçonneries en briques.

Fig. 301.



Fig. 302.

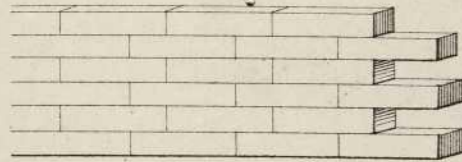


Fig. 303. *Appareil Anglais. (english bond)*

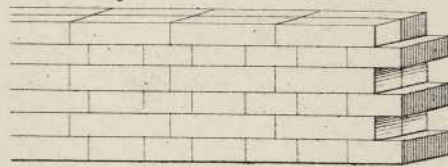


Fig. 304. *Appareil Anglais. (Flemish bond)*

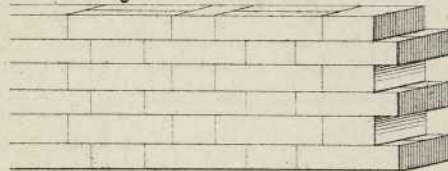


Fig. 305. *Appareil Belge. (Kruisverband)*

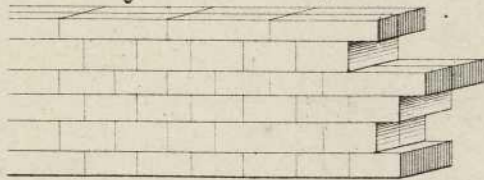


Fig. 306.

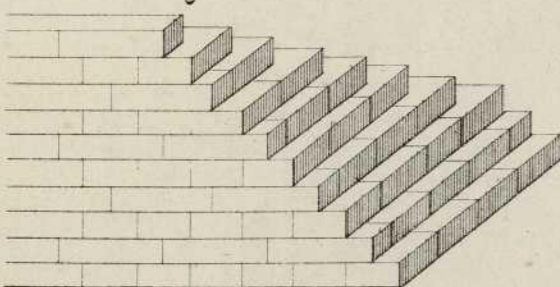


Fig. 307.

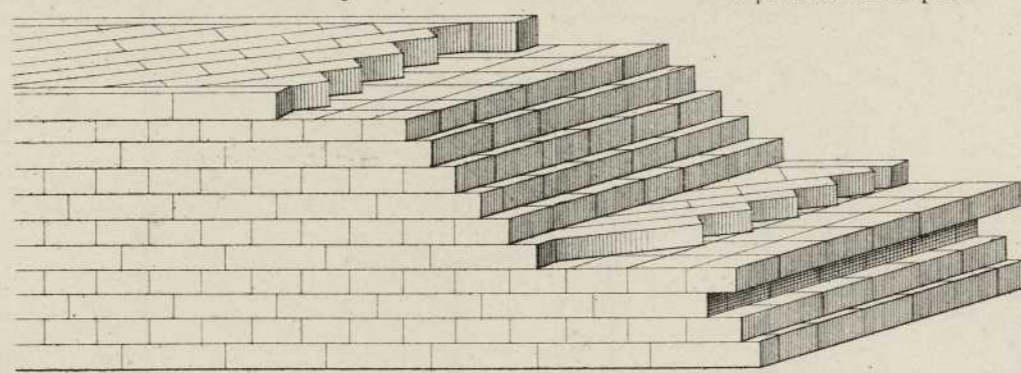


Fig. 308. *Appareil Français.*

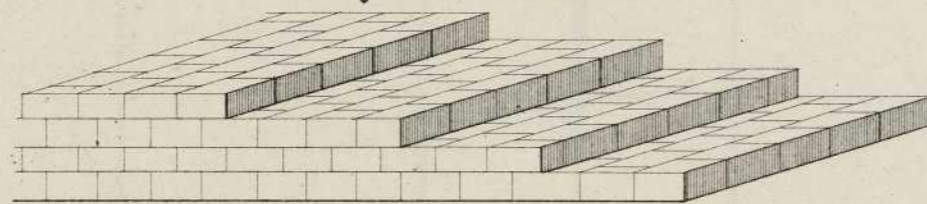


Fig. 309.

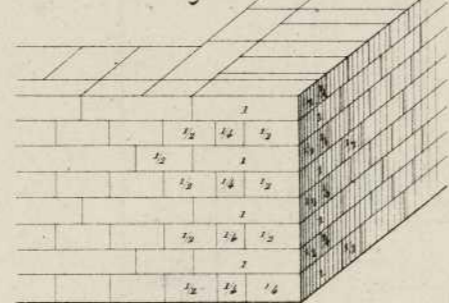


Fig. 310.

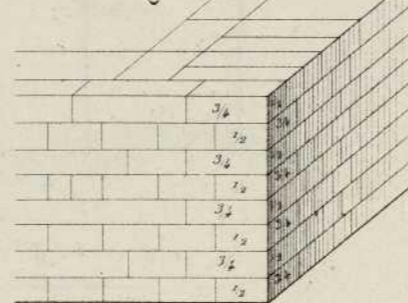


Fig. 311.

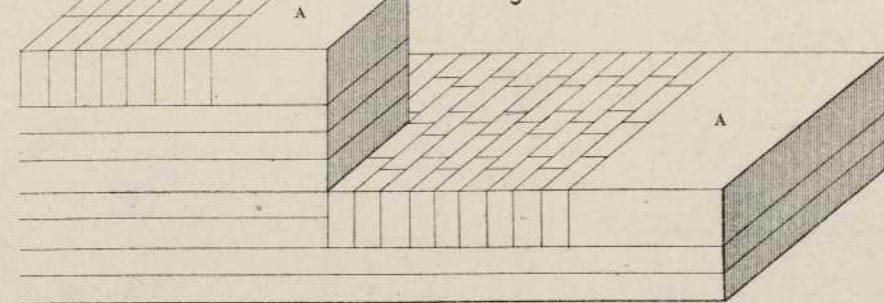


Fig. 312.

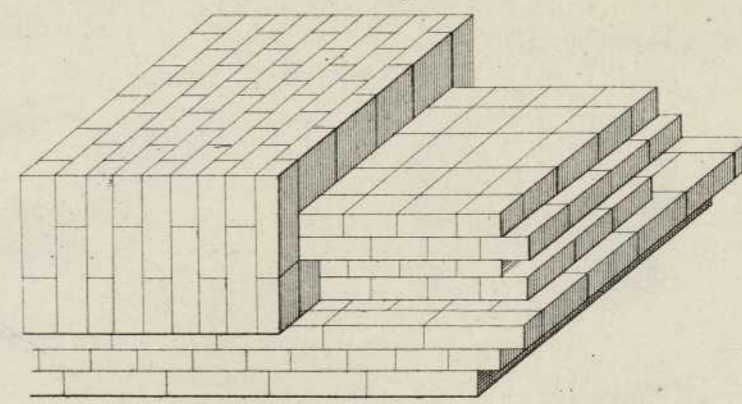


Fig. 313.

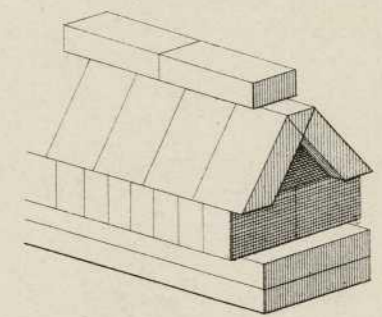


Fig. 315.

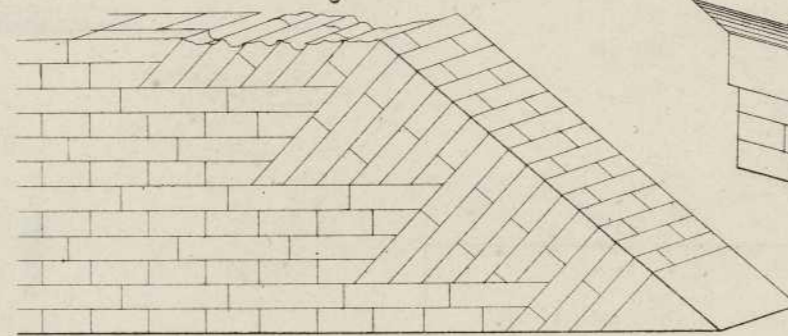


Fig. 314.

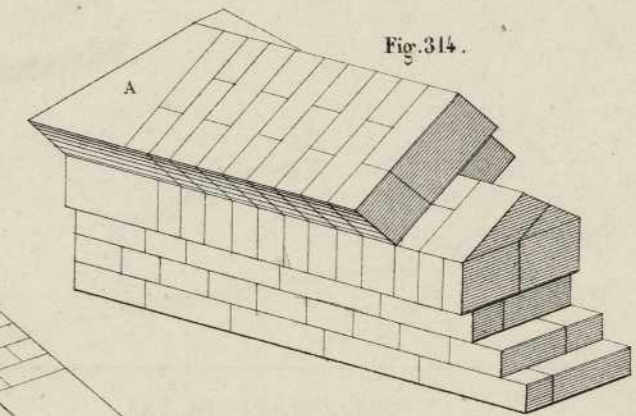


Fig. 316.

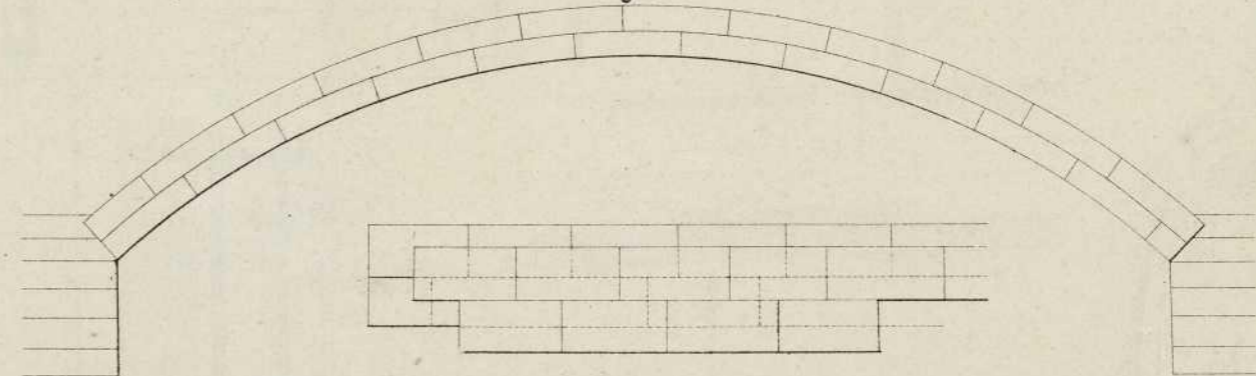
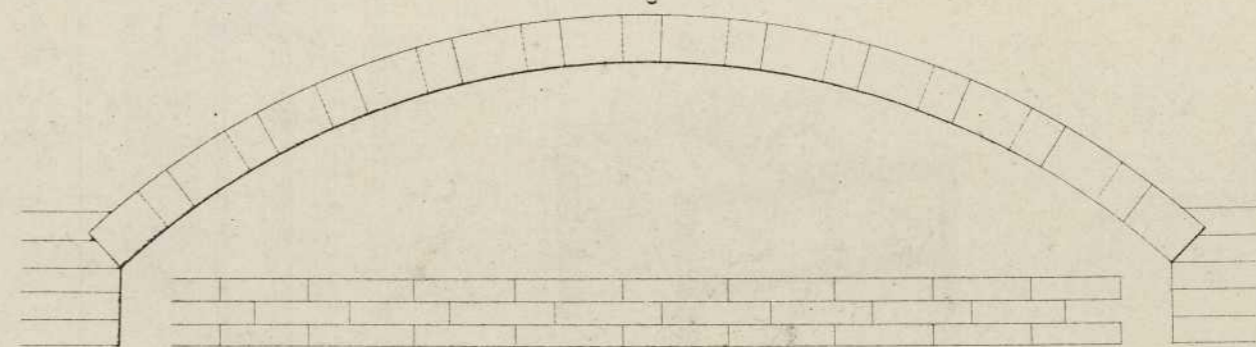
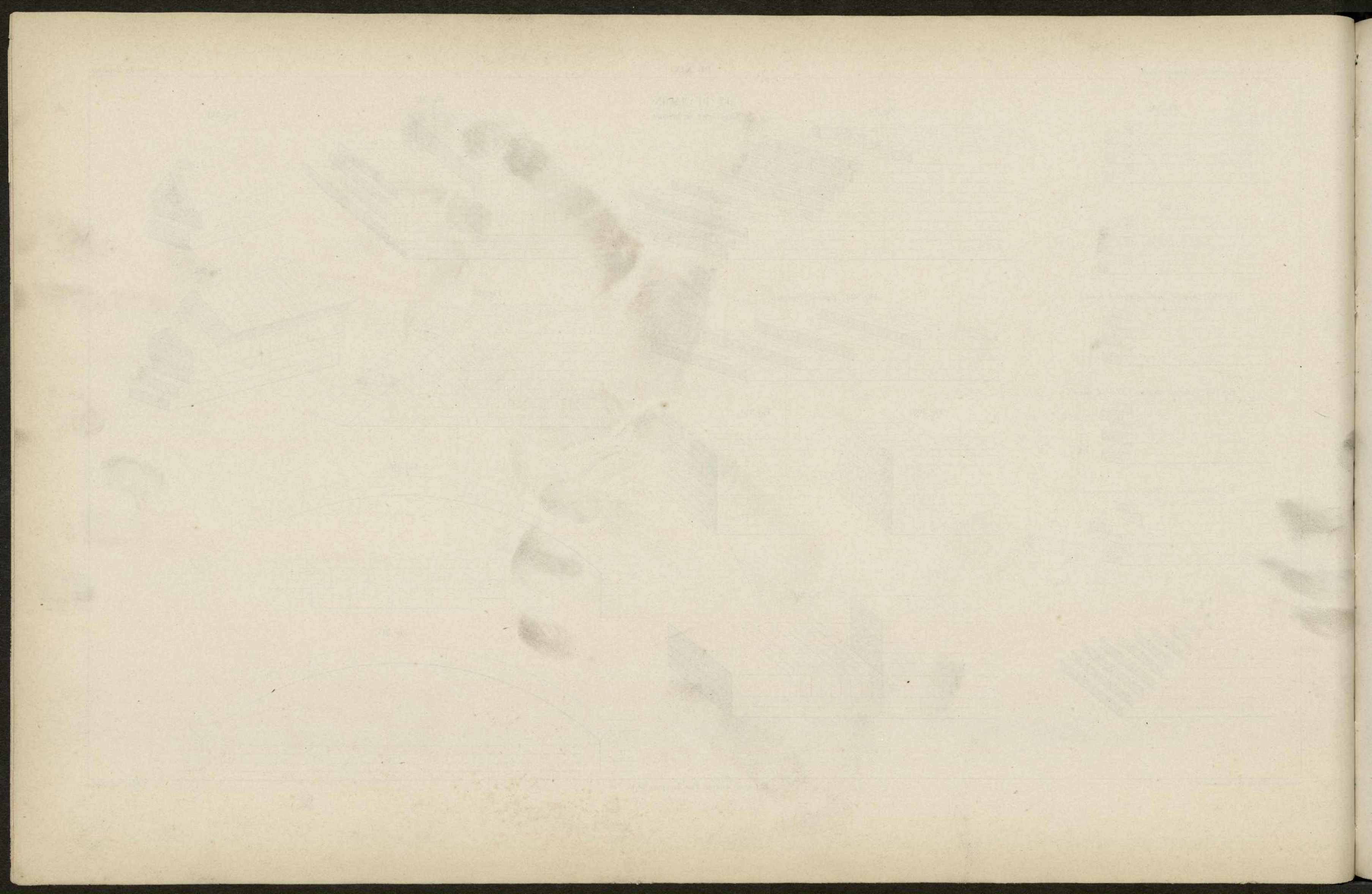


Fig. 317.









Appareil des voutes en briques.

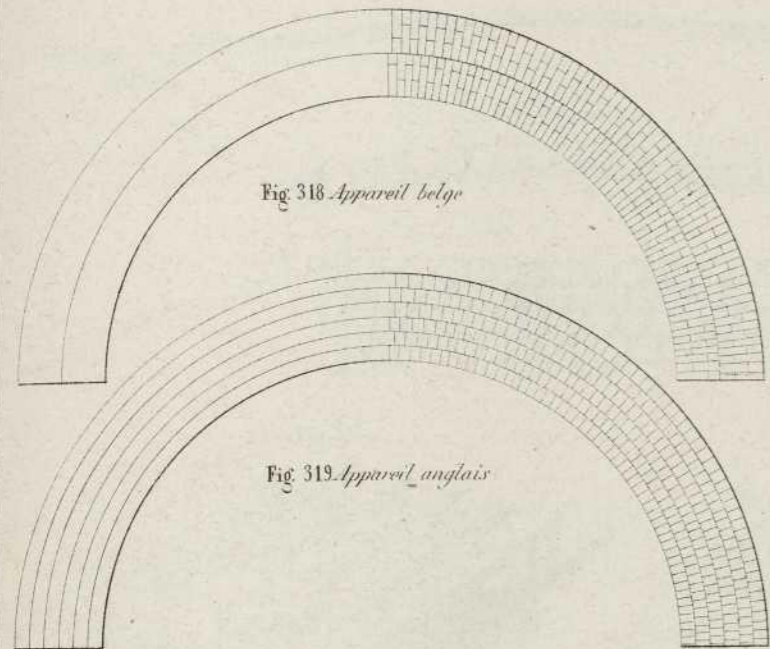


Fig. 318 Appareil belge

Fig. 319 Appareil anglais

Fig. 320

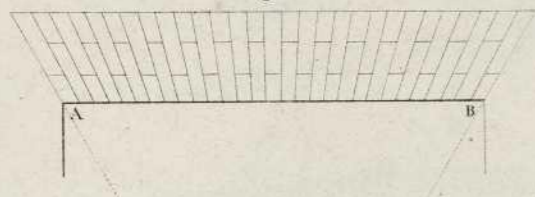
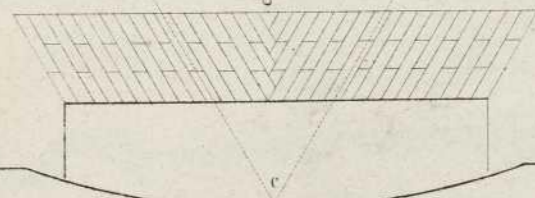


Fig. 321



Maçonnerie en Pisé et en Béton.

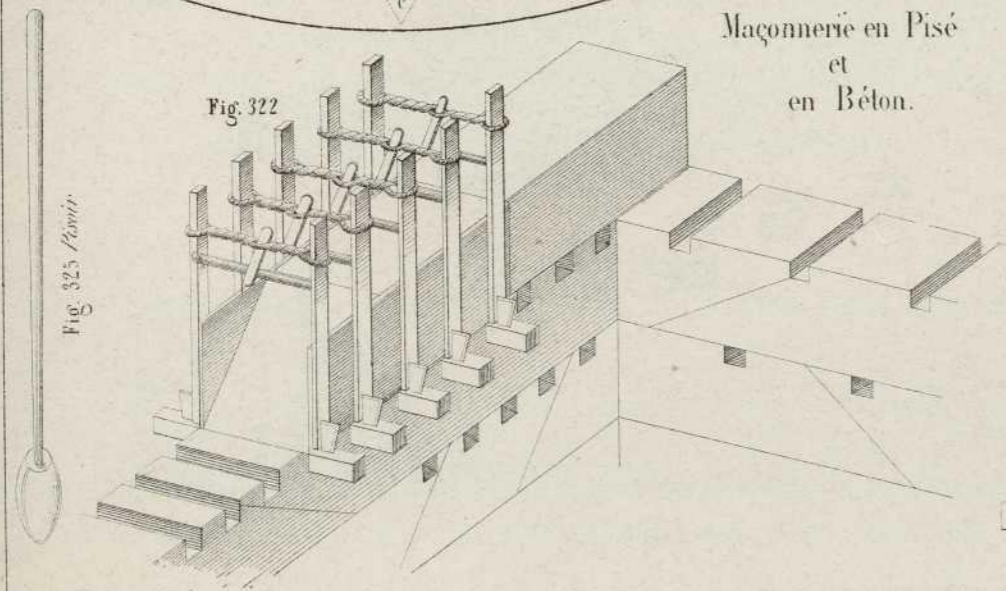


Fig. 322

Fig. 325 Manivelle

Fig. 326 Echafaudage de maçon.

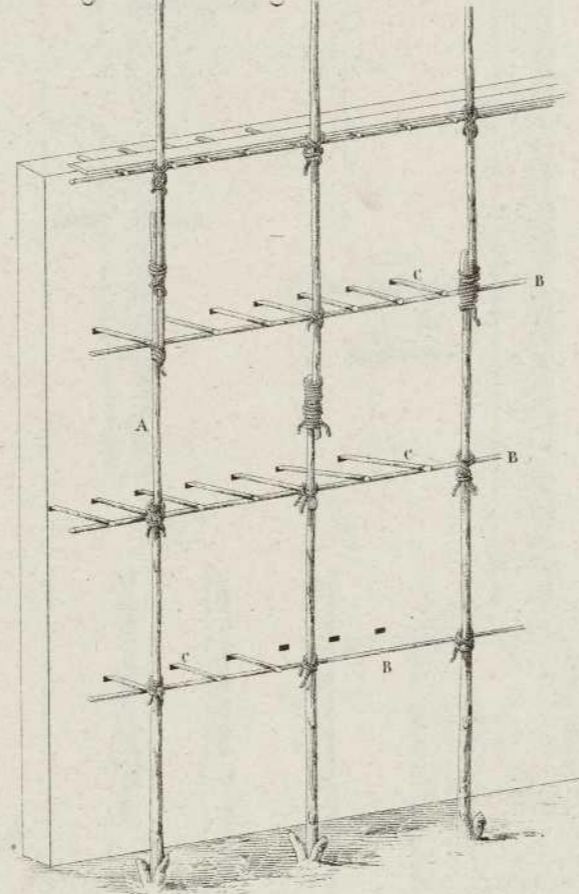


Fig. 323 Banche

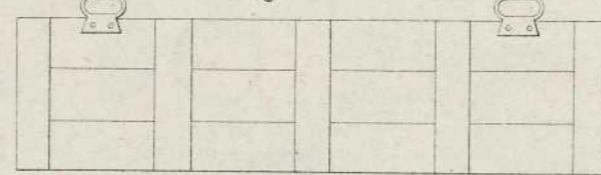


Fig. 324

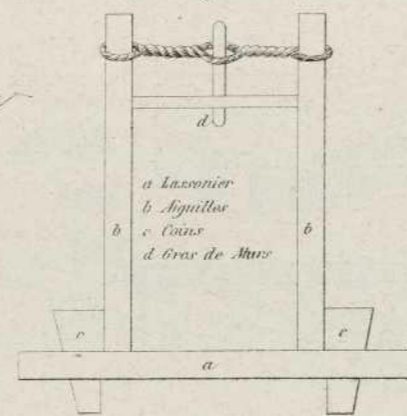
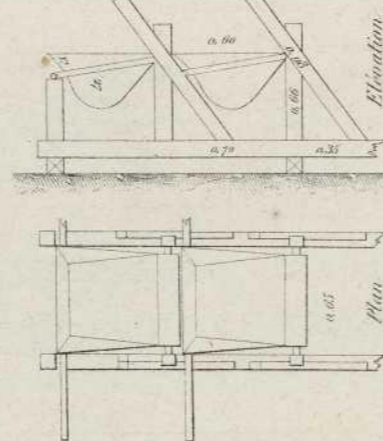


Fig. 325 bis

Machine à Coffres



ART DU MAÇON.

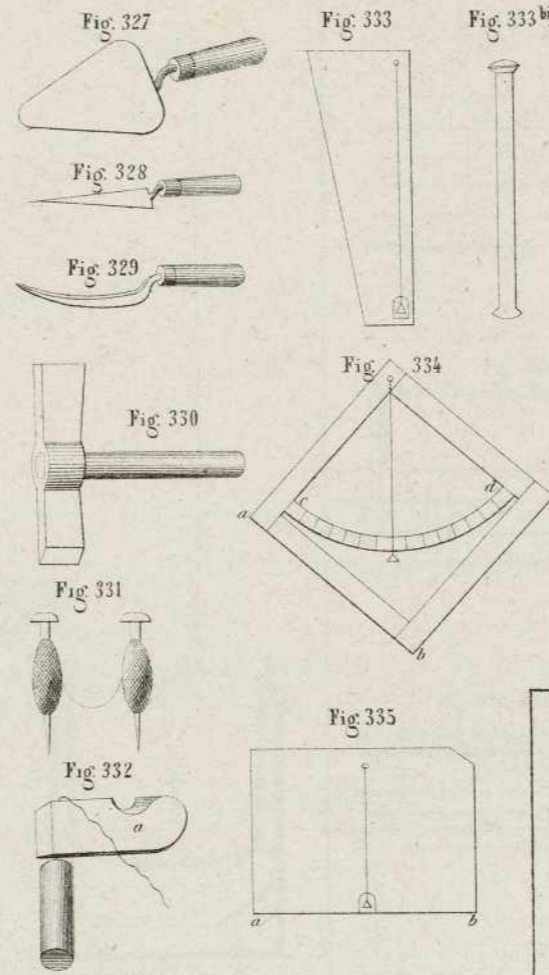


Fig. 327

Fig. 328

Fig. 329

Fig. 330

Fig. 331

Fig. 332

Fig. 333

Fig. 333 bis

Fig. 334

Fig. 335

Outils du maçon et du plafonneur.

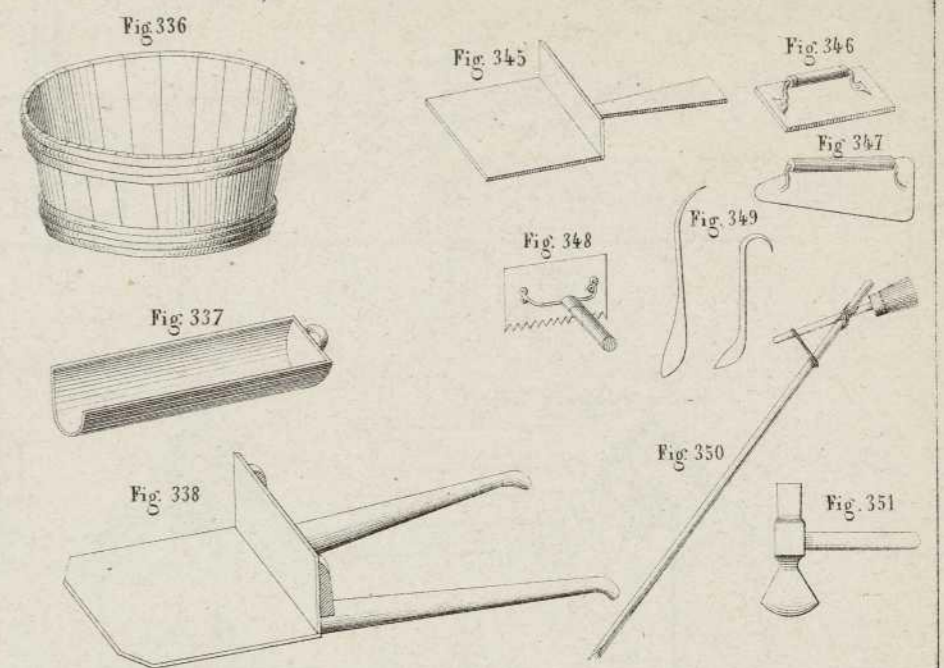


Fig. 336

Fig. 345

Fig. 346

Fig. 347

Fig. 348

Fig. 349

Fig. 350

Fig. 351

ART DU PLAFONNEUR.

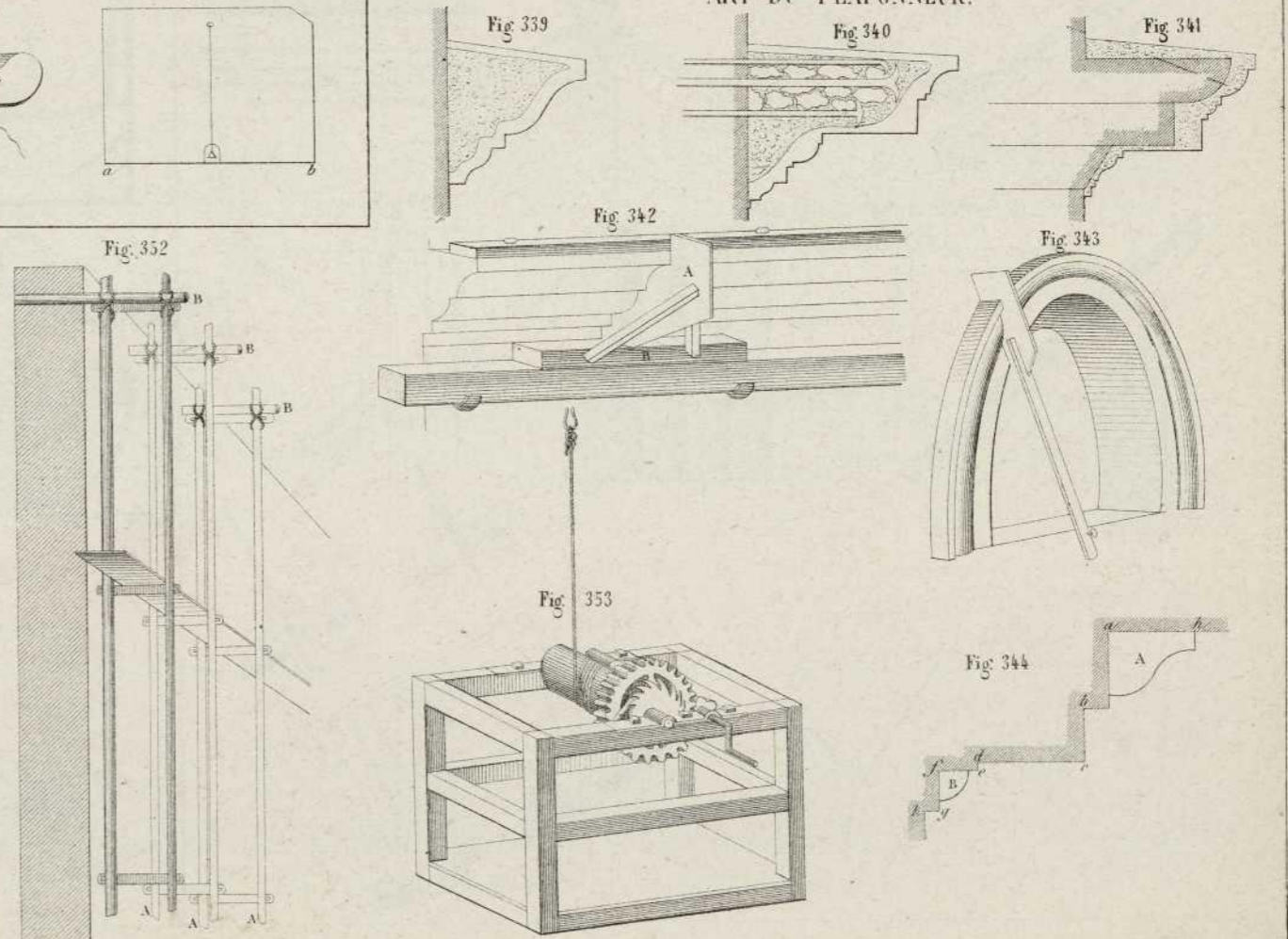


Fig. 339

Fig. 340

Fig. 341

Fig. 342

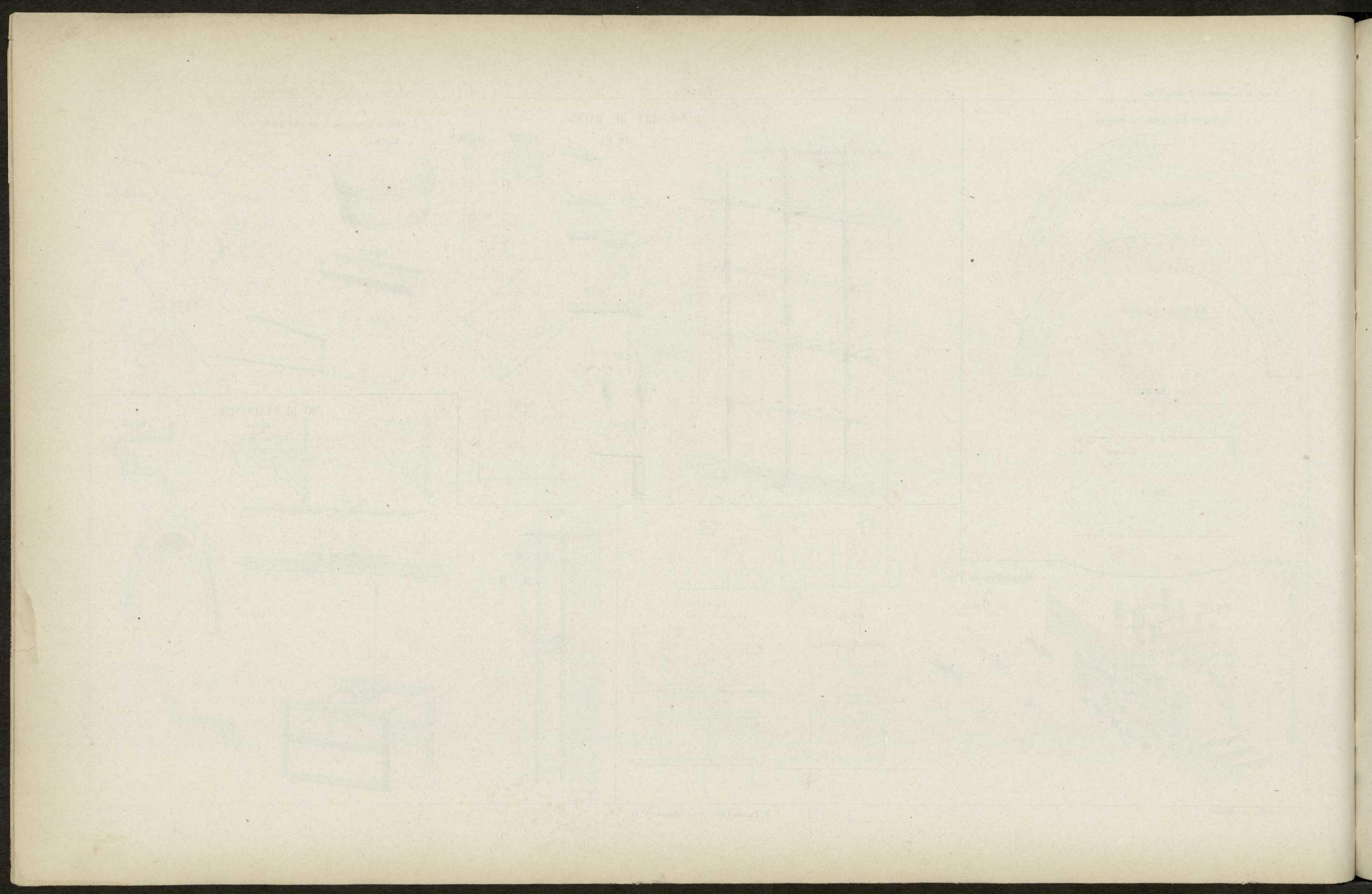
Fig. 343

Fig. 344

Fig. 352

Fig. 353



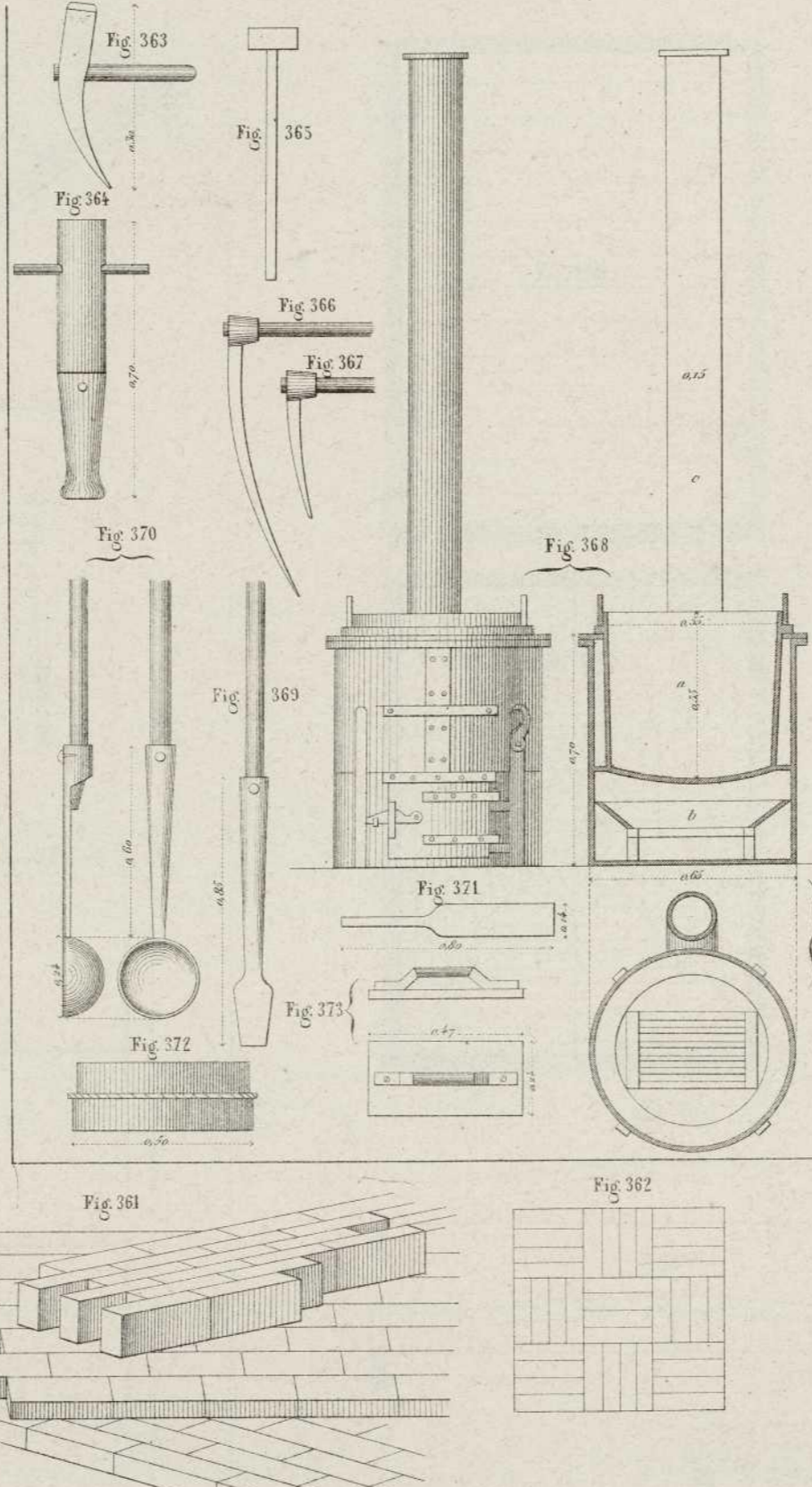
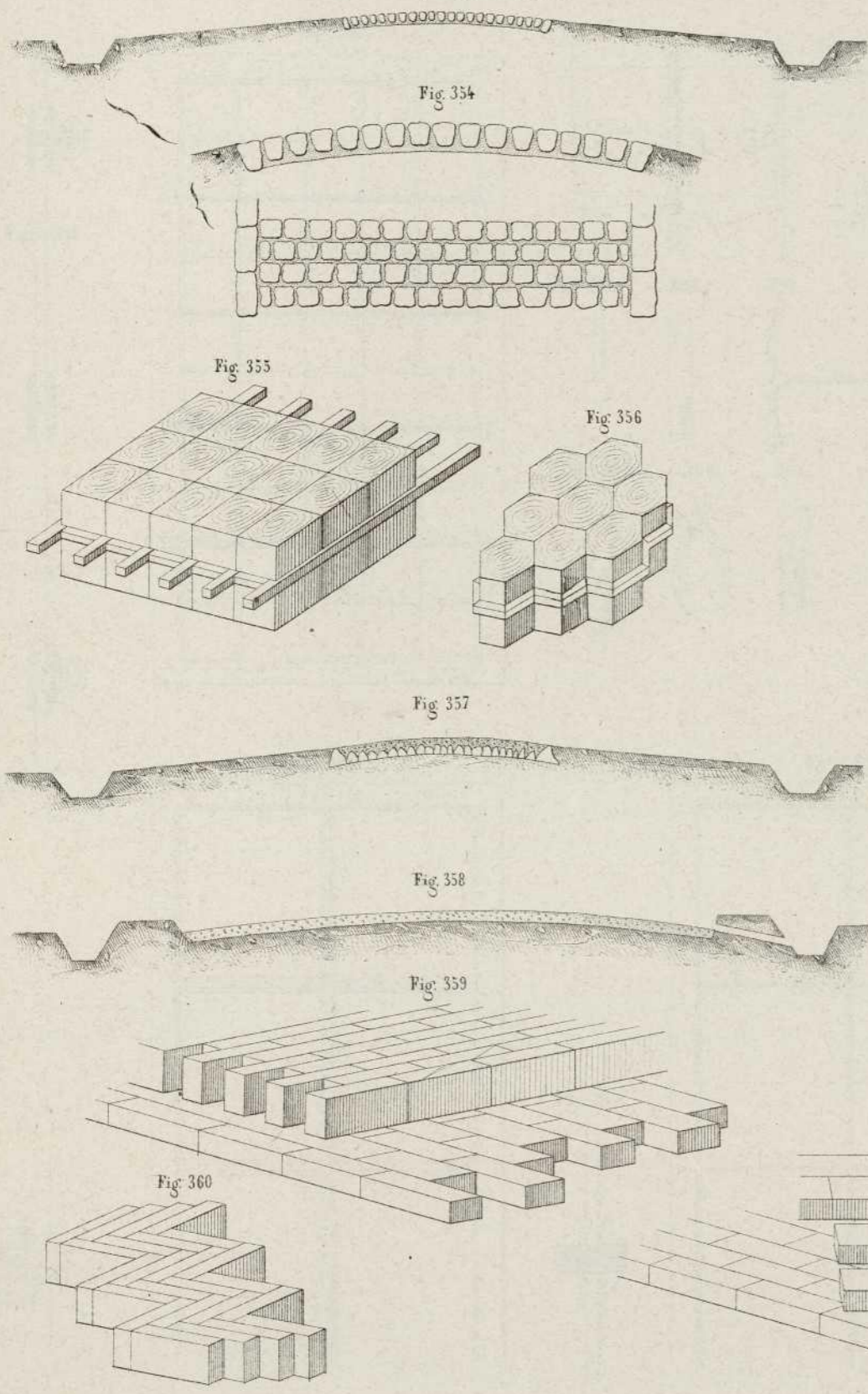




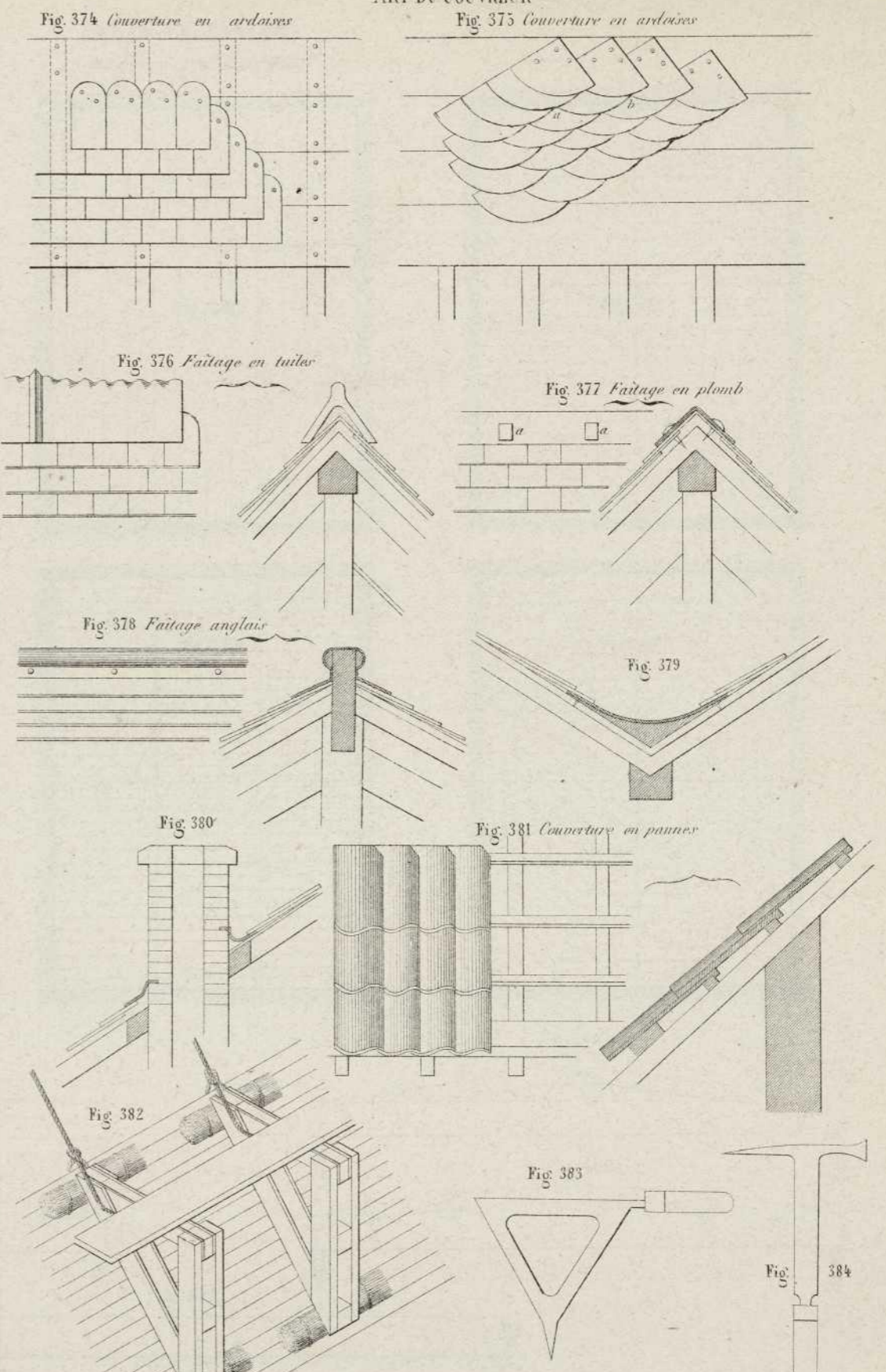
ART DU PAVEUR ET DU CARRELEUR.

Diverses espèces de pavages et d'aires.

Outils du paveur et du carreleur.



ART DU COUVREUR



Conçu par Edouard Buisson, architecte.

Paris Imp. Mouton



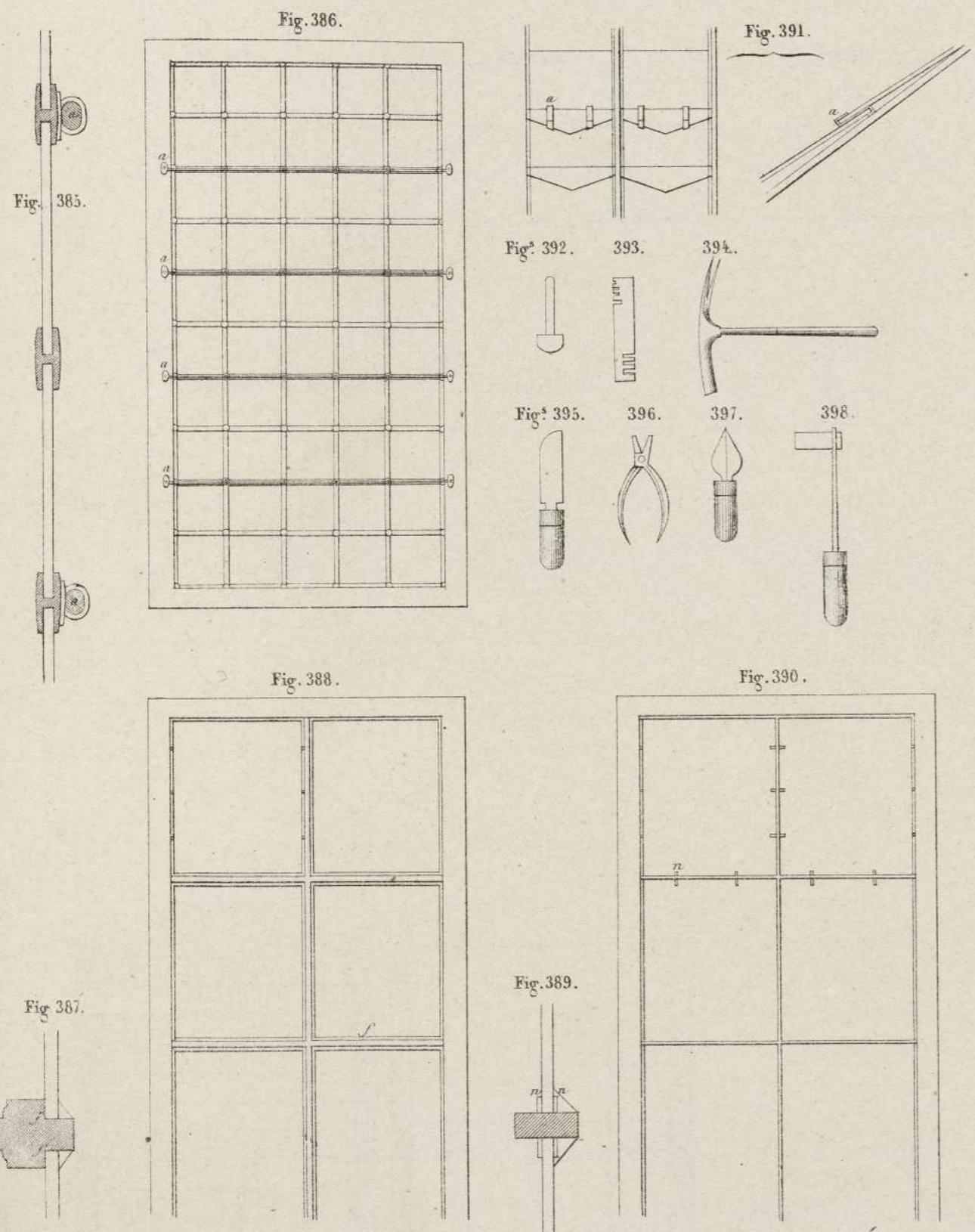
ART. DE SÉRIE ET DE SÉRIER

Tableau de la Série

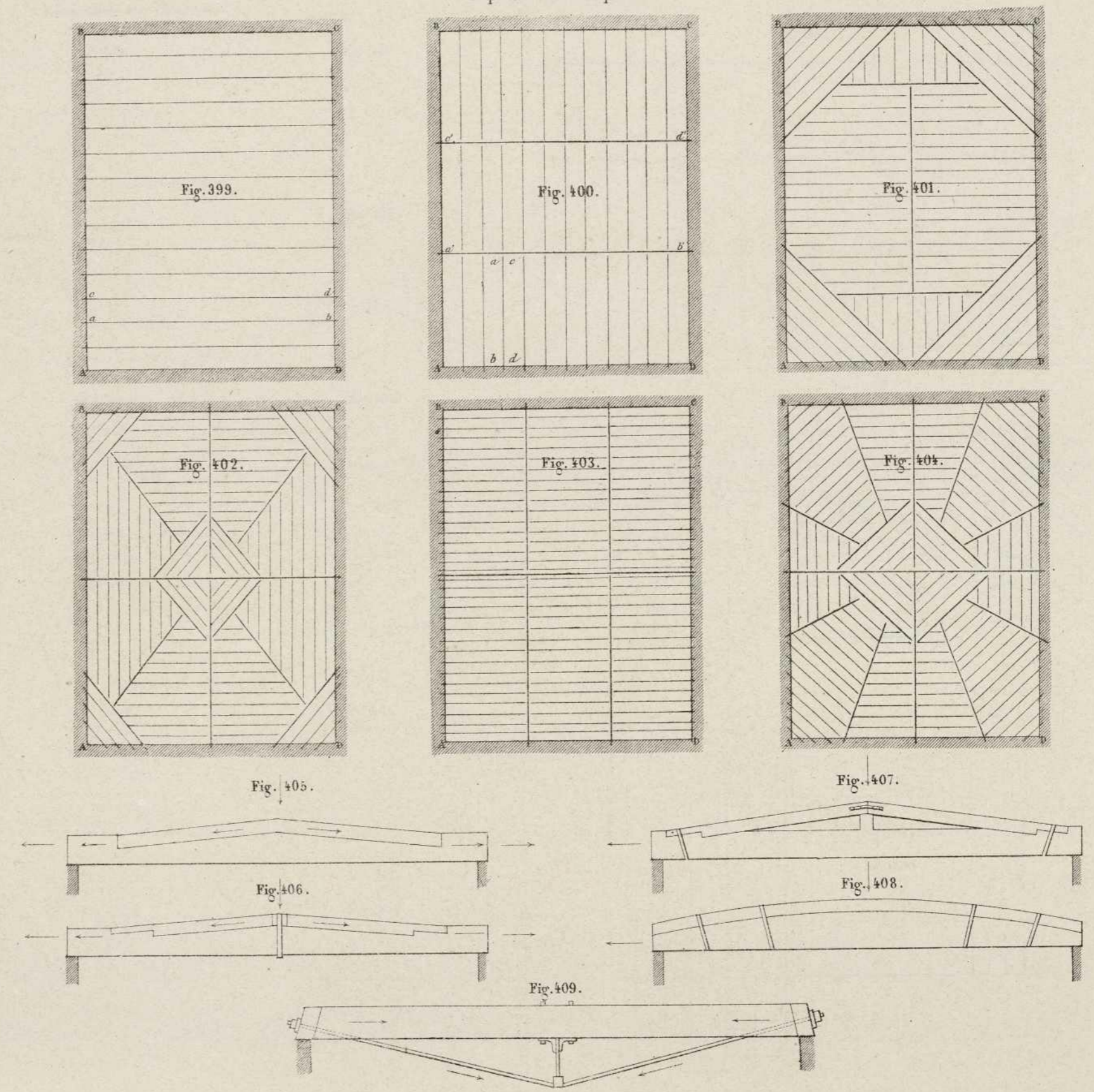
Série	Sériér	Sériér	Sériér	Sériér	Sériér
Série 1	Sériér 1	Sériér 1	Sériér 1	Sériér 1	Sériér 1
Série 2	Sériér 2	Sériér 2	Sériér 2	Sériér 2	Sériér 2
Série 3	Sériér 3	Sériér 3	Sériér 3	Sériér 3	Sériér 3
Série 4	Sériér 4	Sériér 4	Sériér 4	Sériér 4	Sériér 4
Série 5	Sériér 5	Sériér 5	Sériér 5	Sériér 5	Sériér 5
Série 6	Sériér 6	Sériér 6	Sériér 6	Sériér 6	Sériér 6
Série 7	Sériér 7	Sériér 7	Sériér 7	Sériér 7	Sériér 7



ART DU VITRIER.



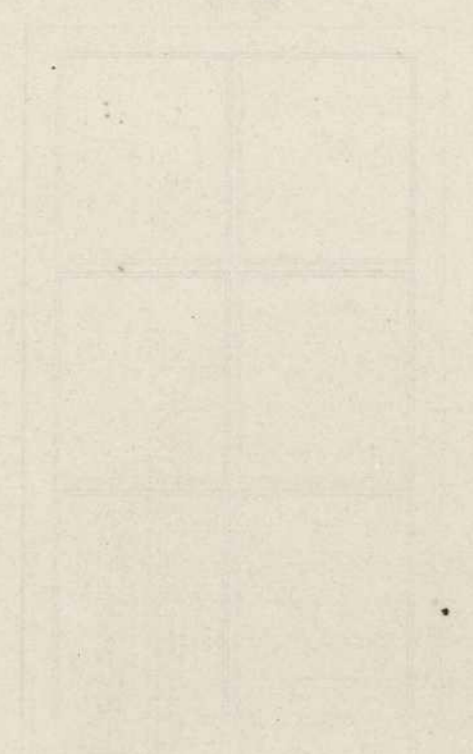
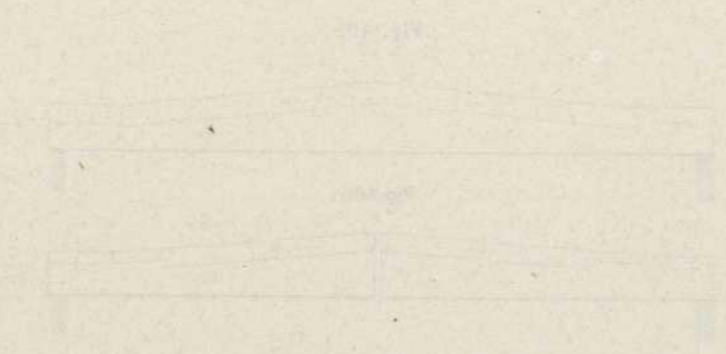
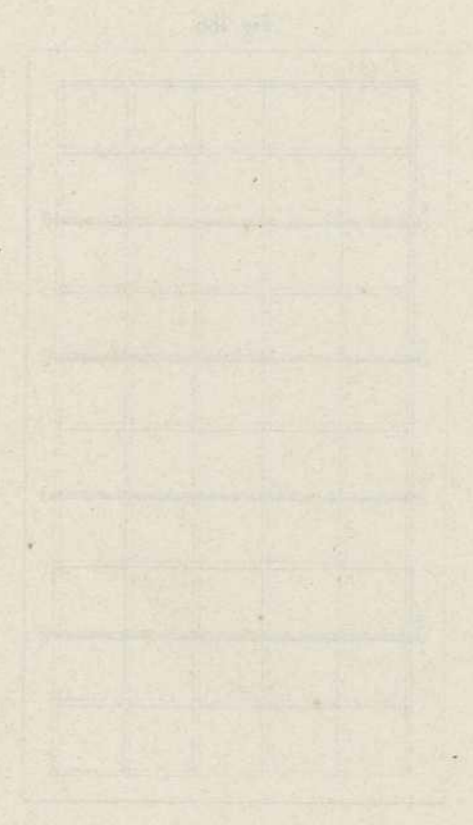
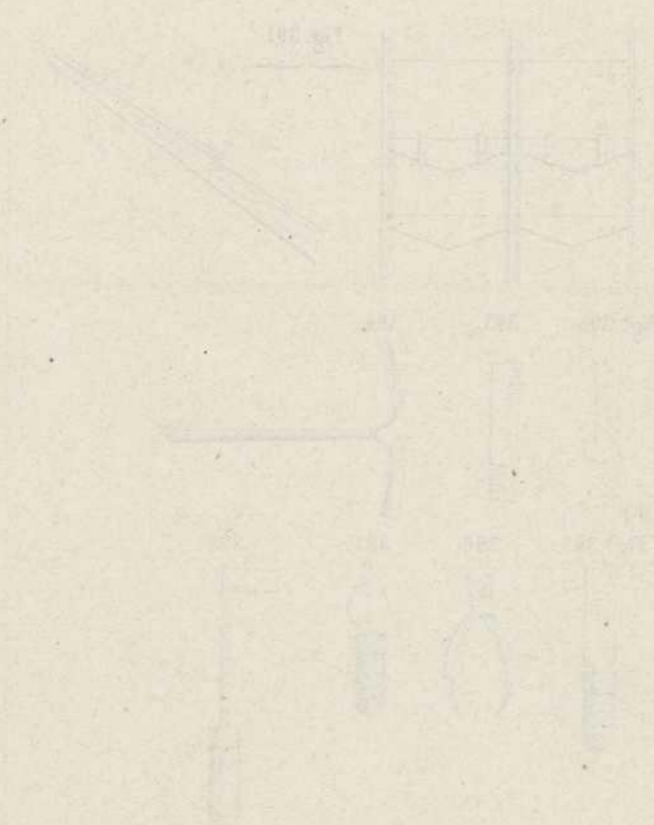
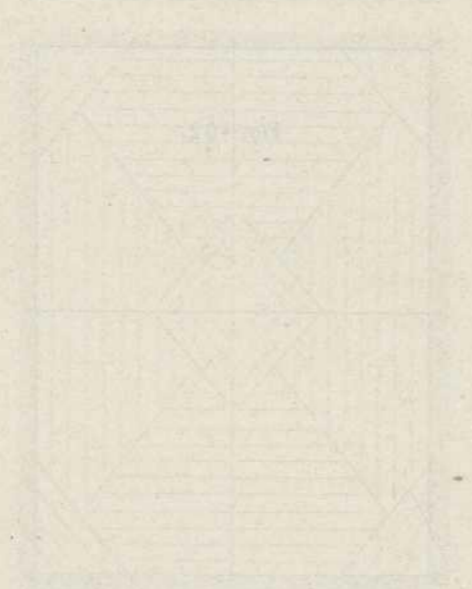
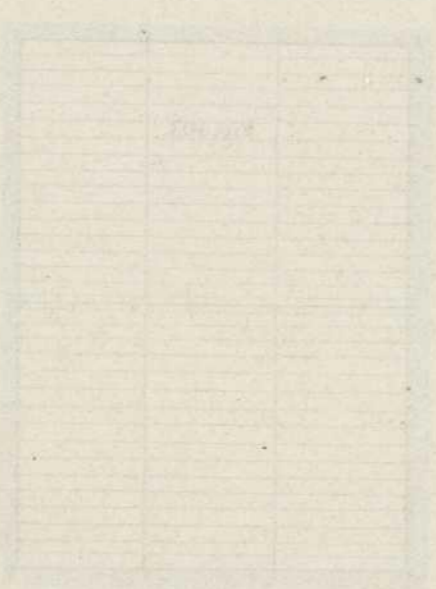
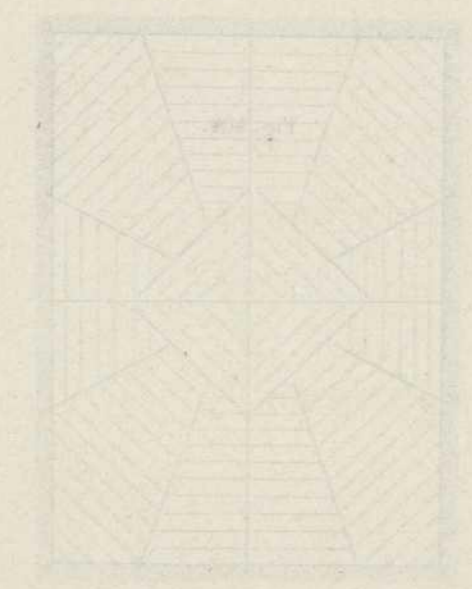
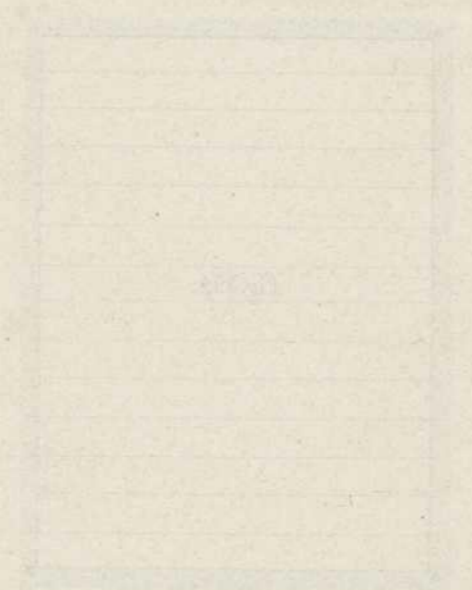
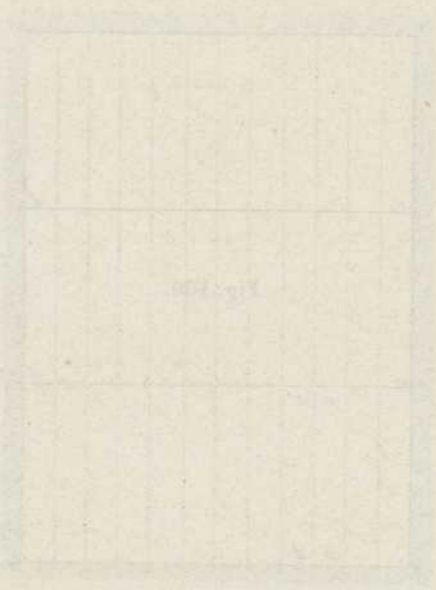
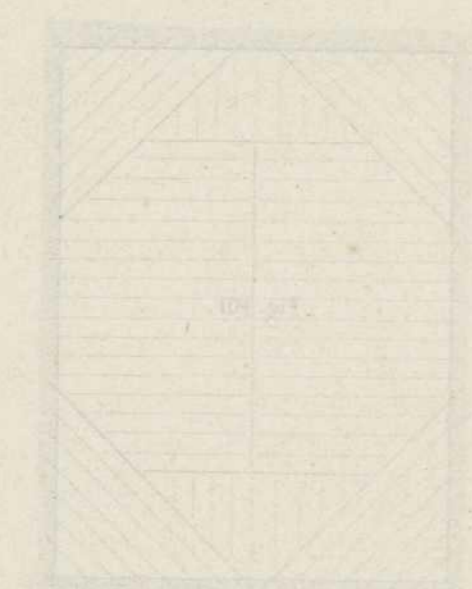
ART DU CHARPENTIER.  
Composition des Charpentes.





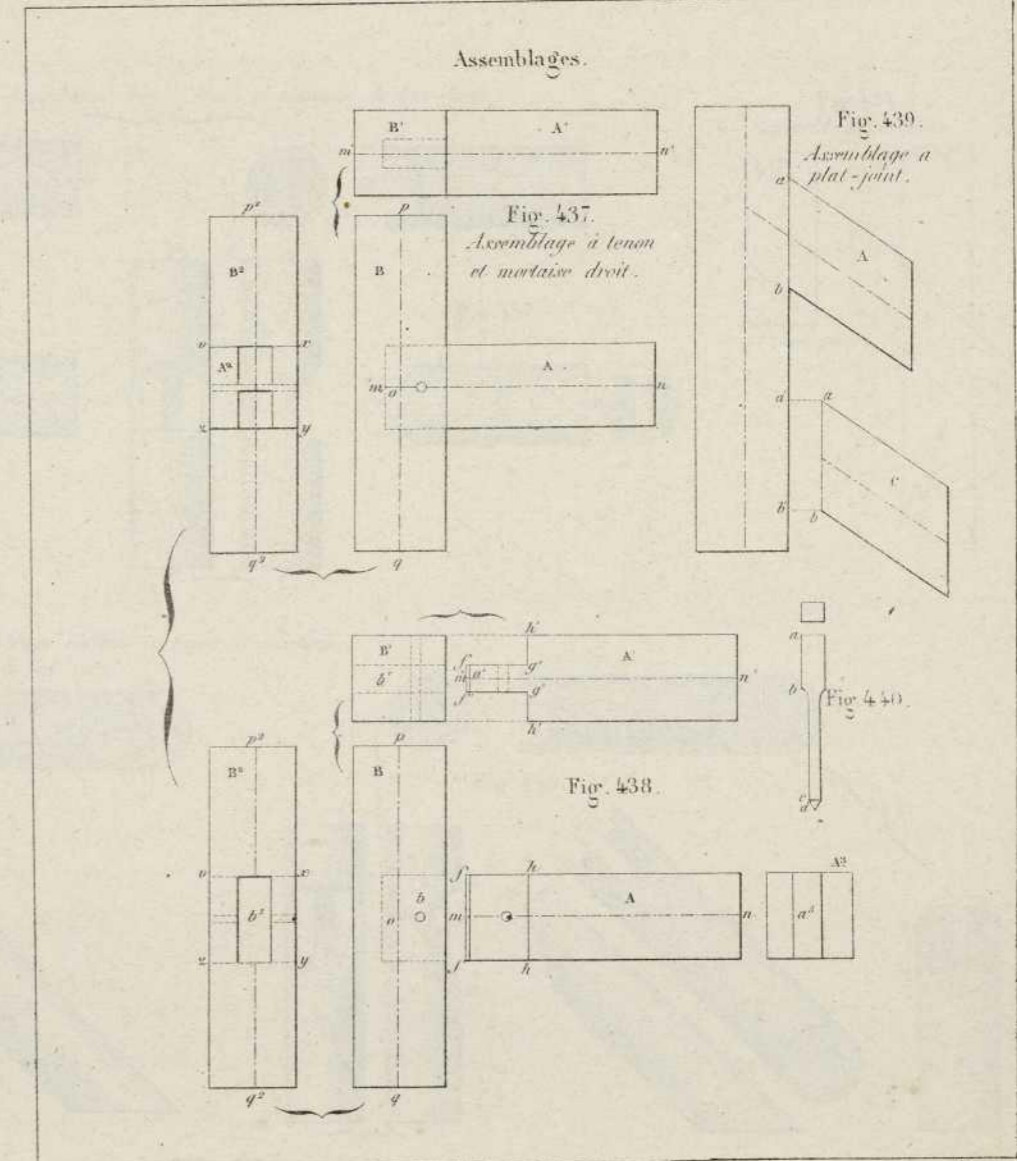
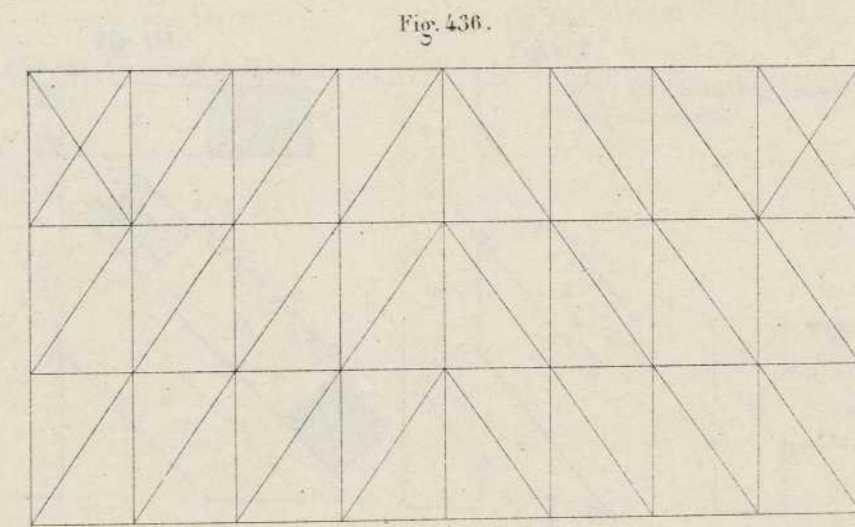
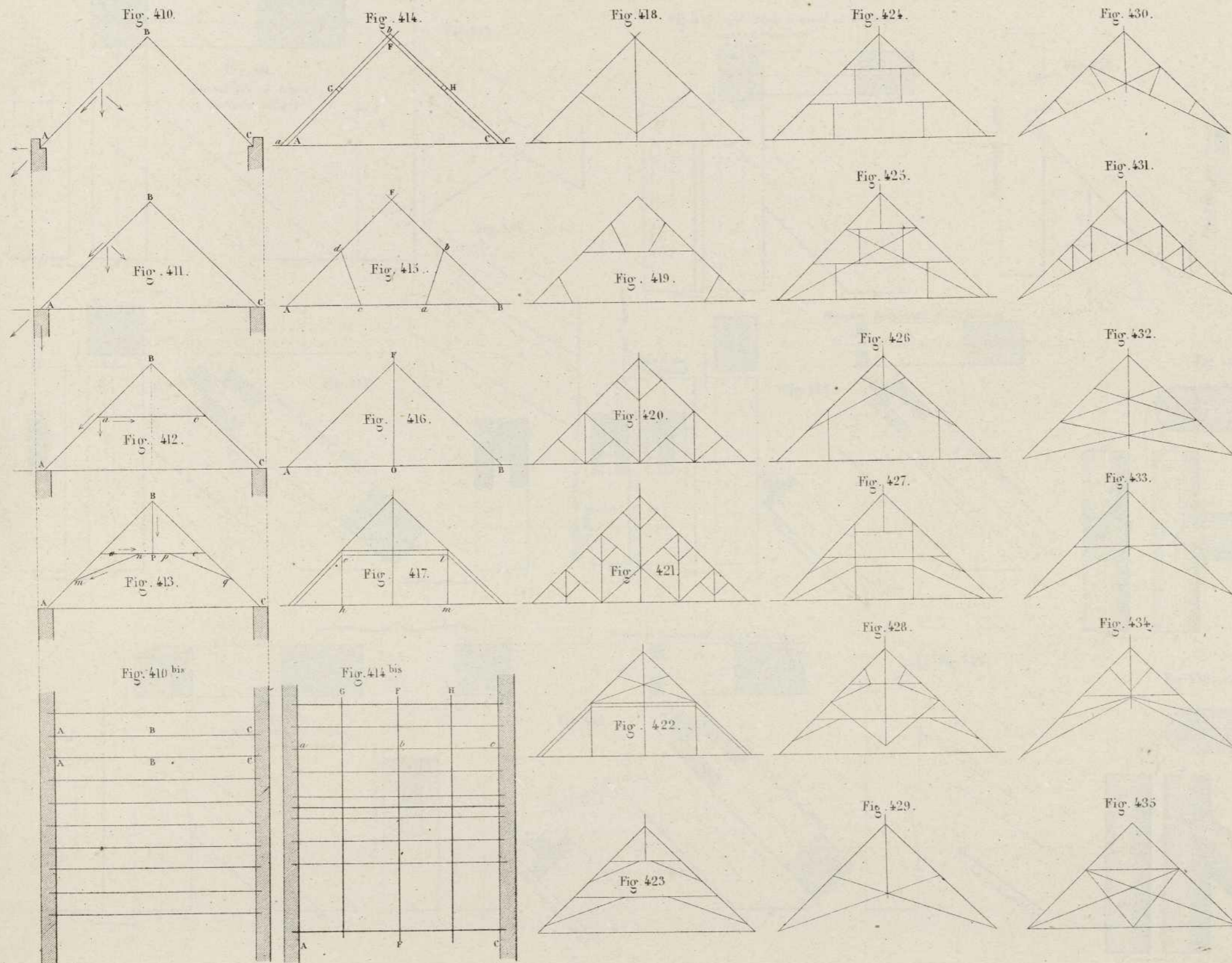
ART DE VINCENZI  
Composition des Grilles

ART DE VINCENZI





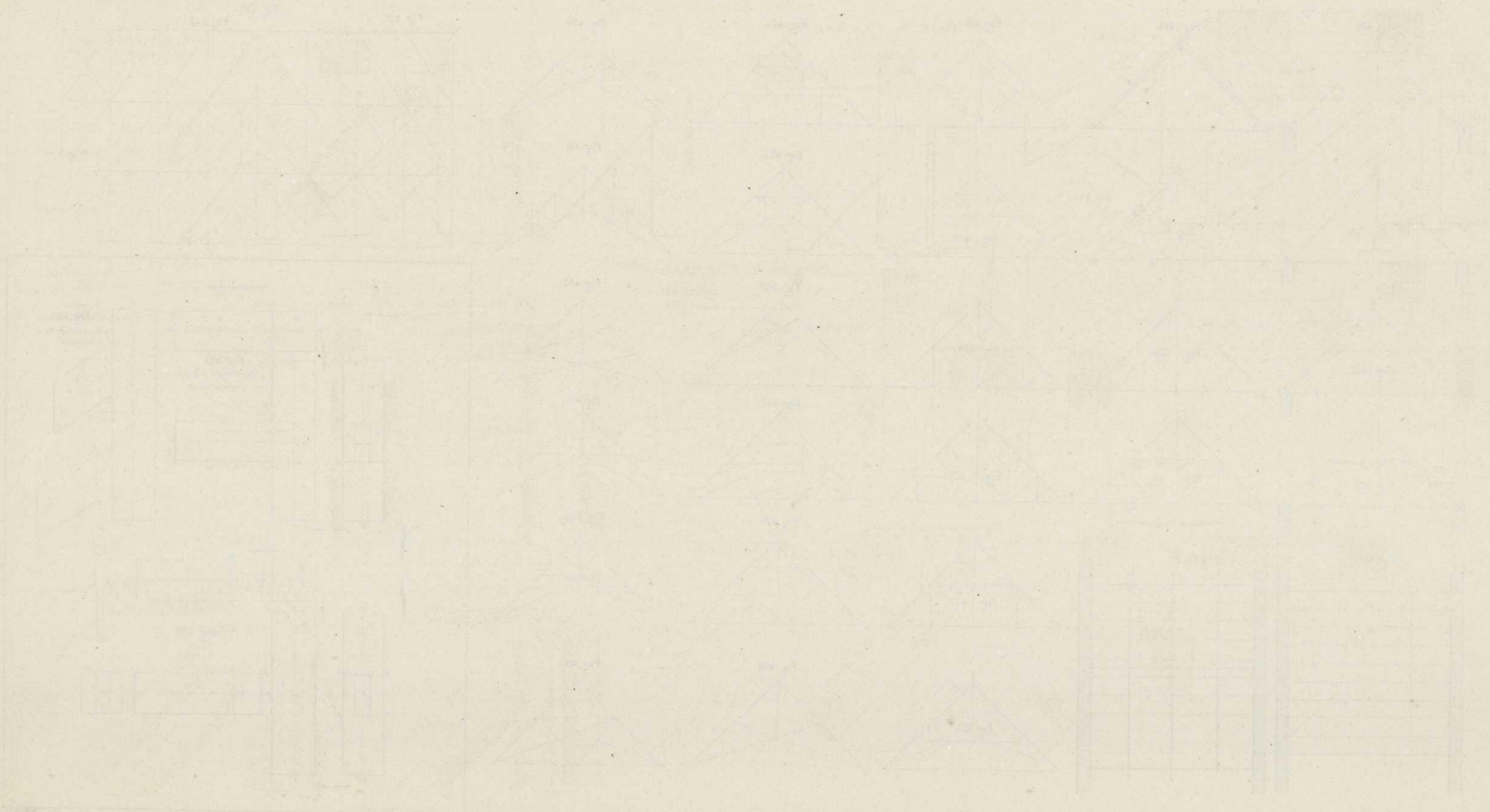
ART DU CHARPENTIER.  
Composition des Charpentes.



Gravé par Erhard, Rue Bonaparte 42.



THE TEMPLE OF  
PHILADELPHIA





ART DU CHARPENTIER  
Assemblages.

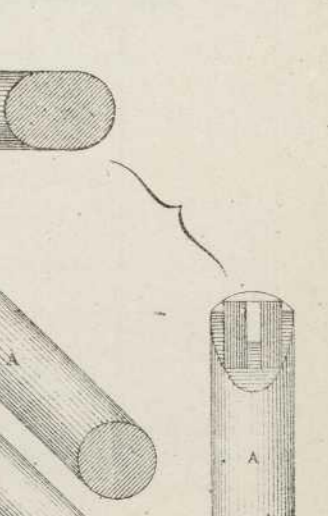
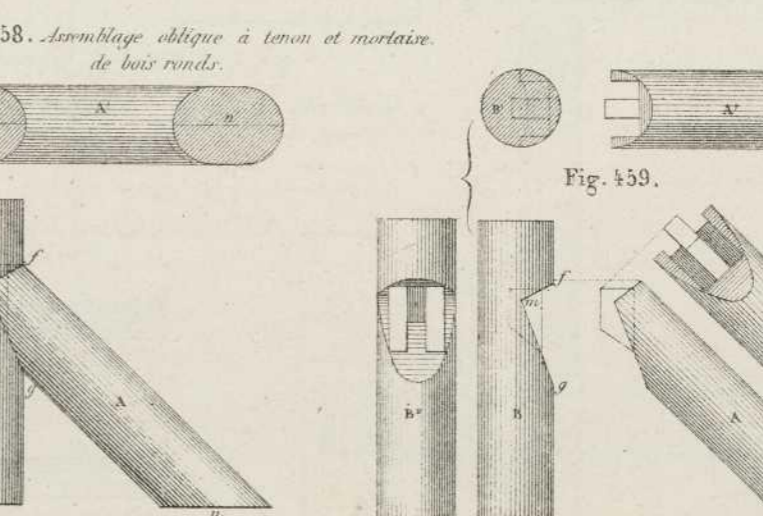
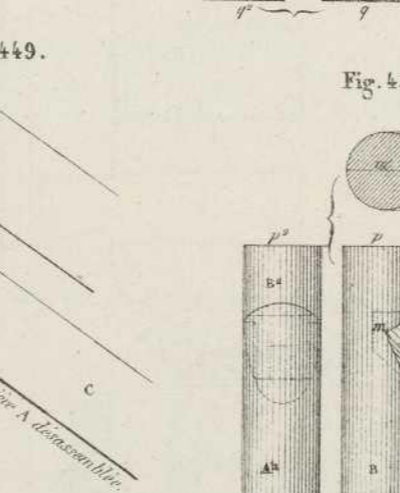
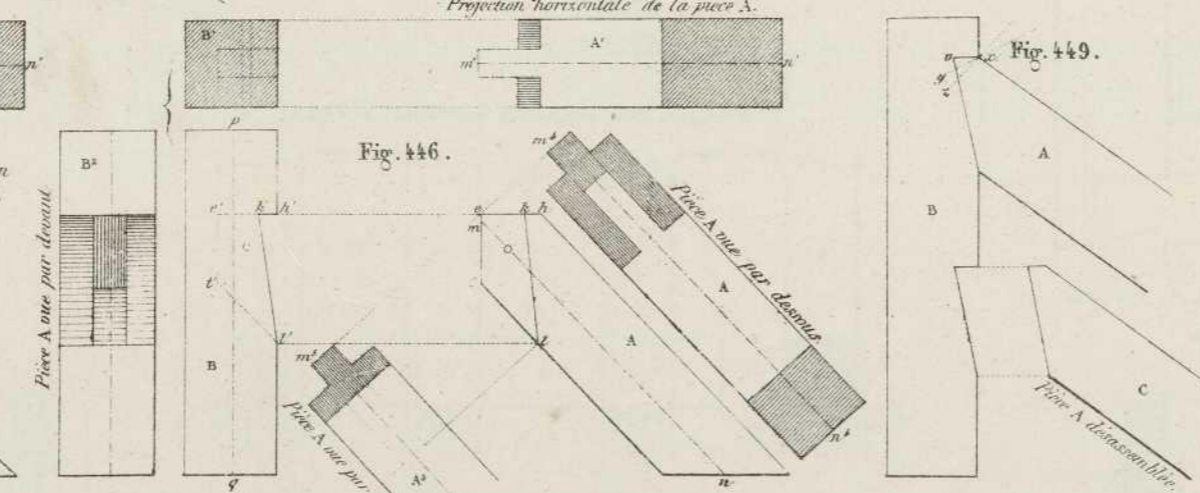
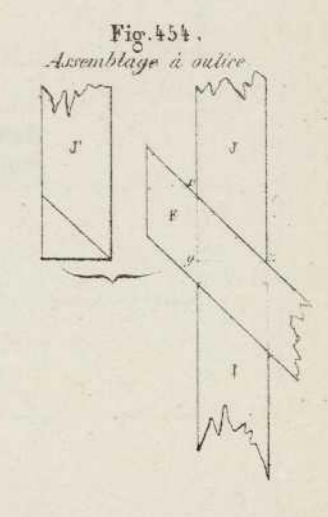
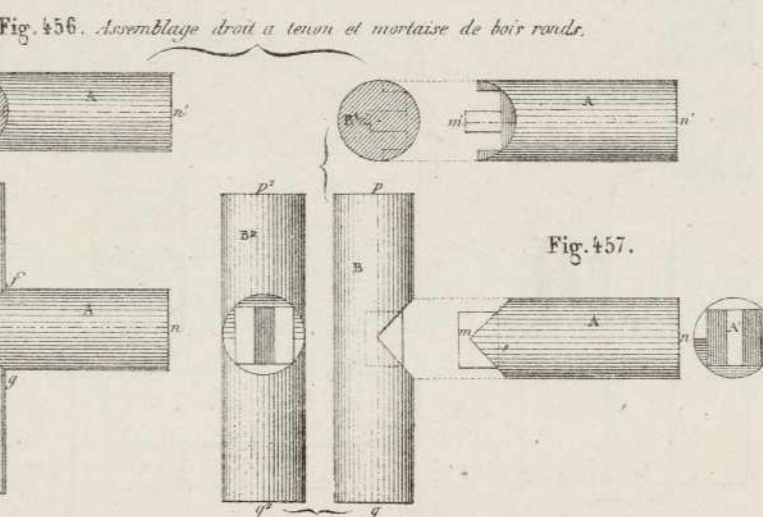
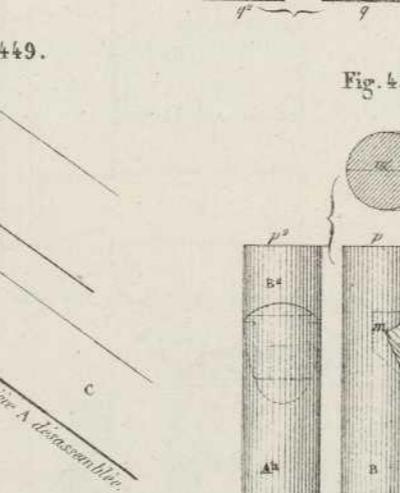
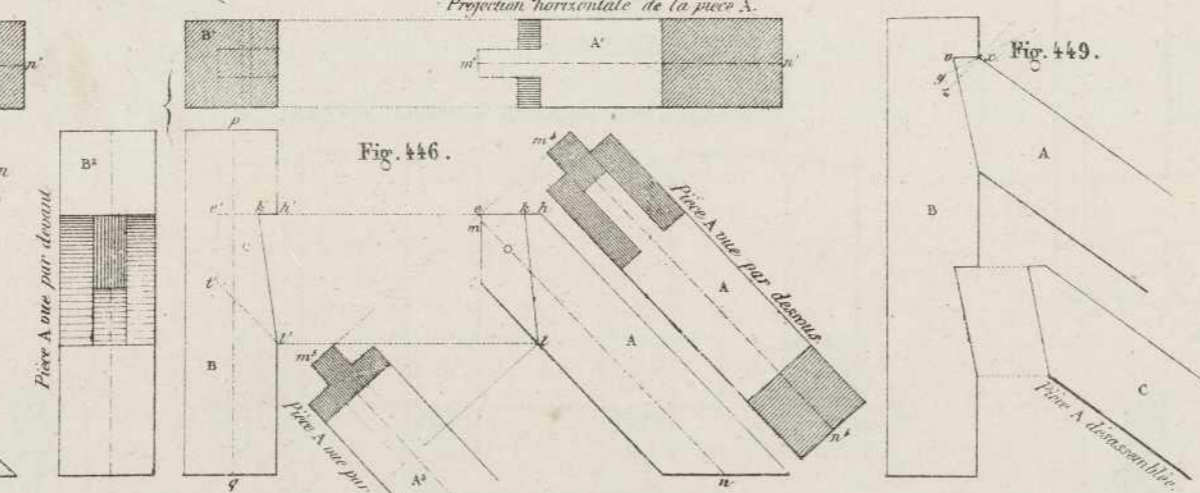
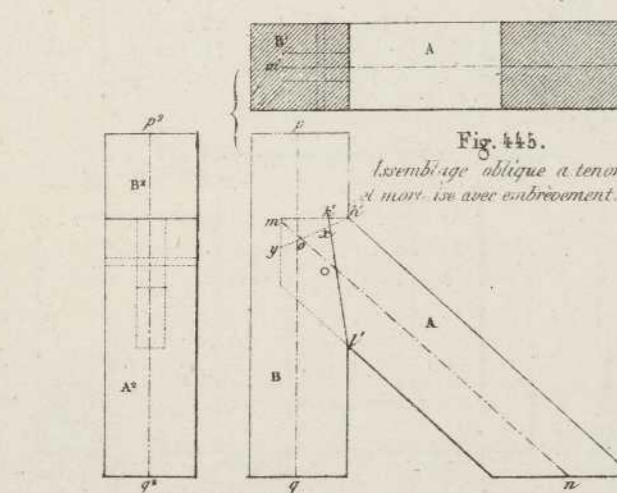
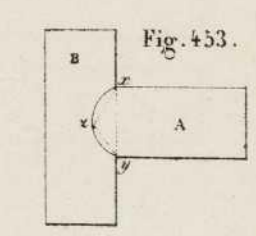
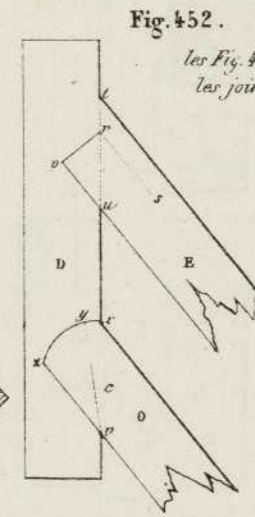
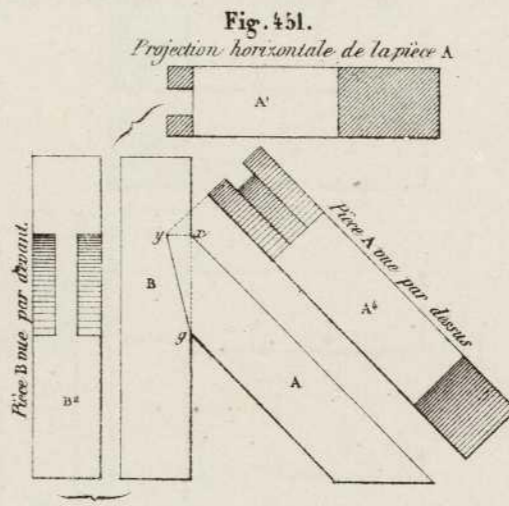
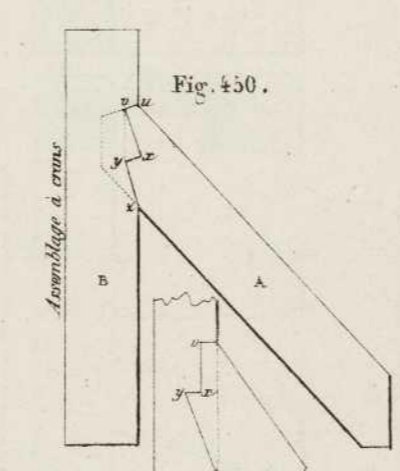
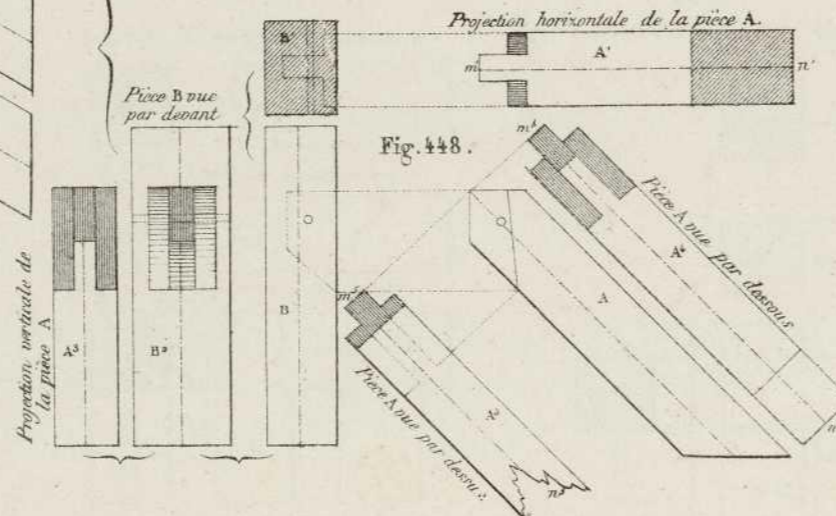
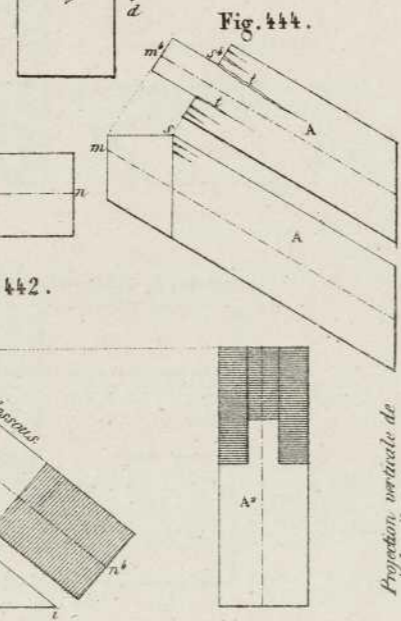
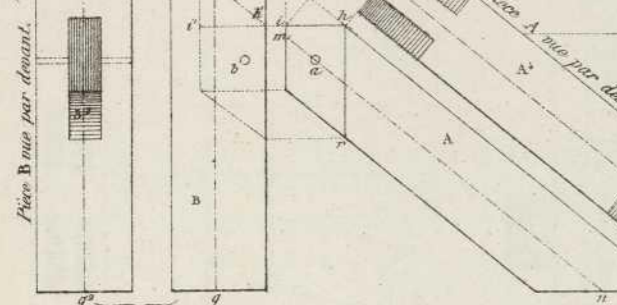
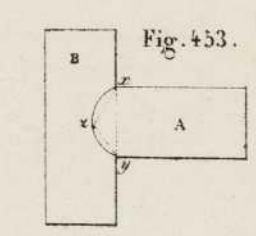
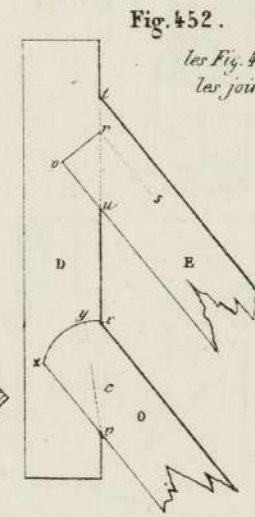
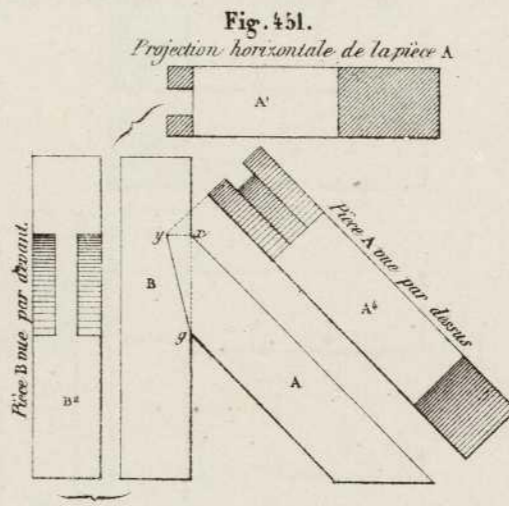
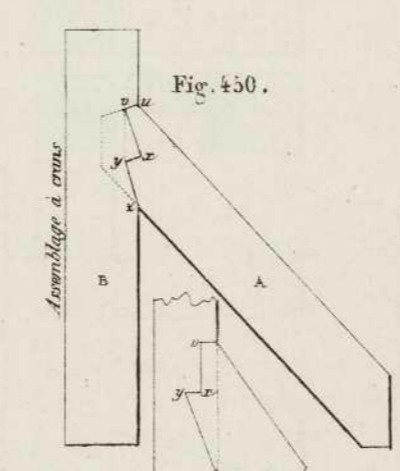
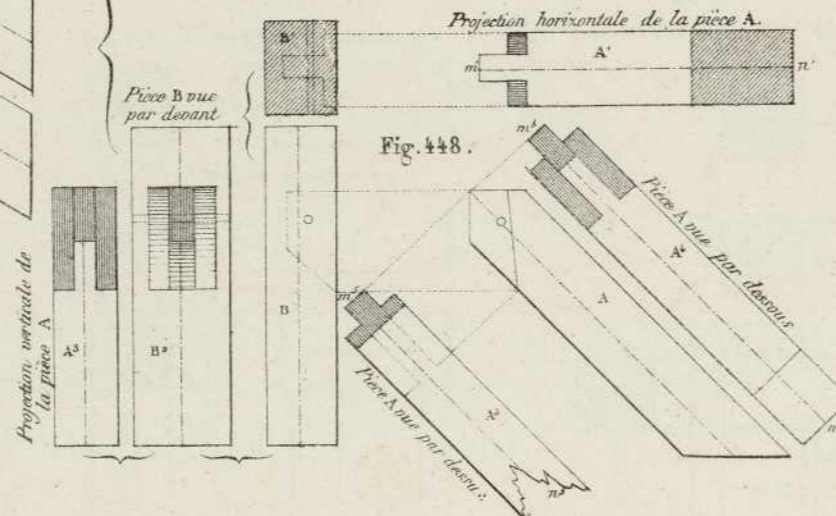
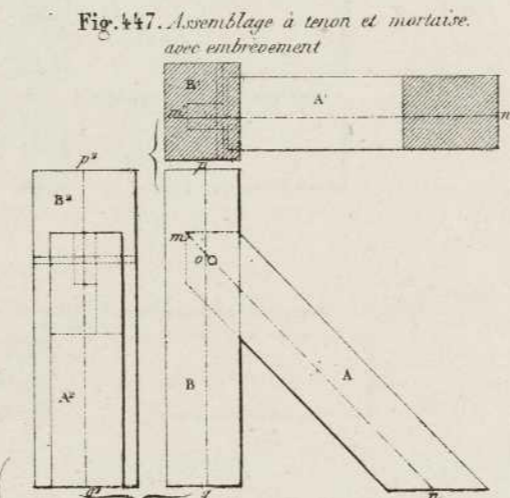
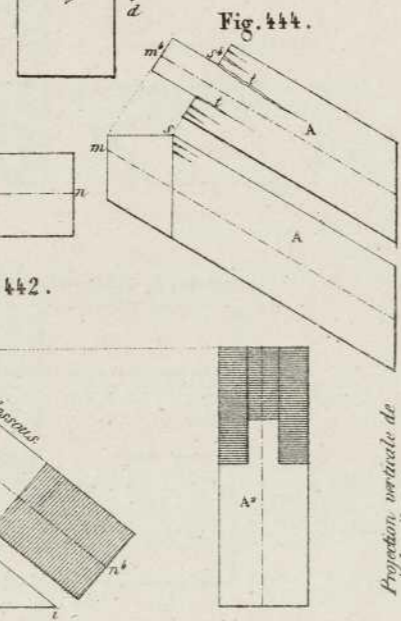
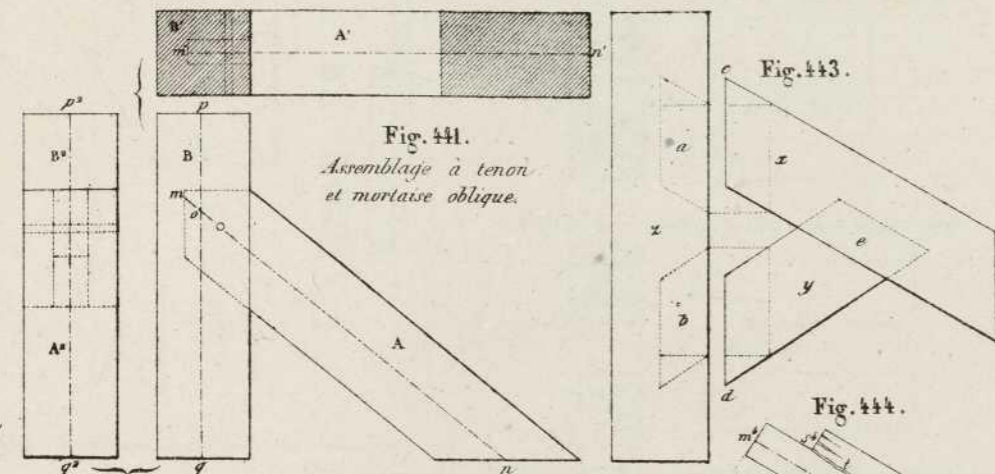
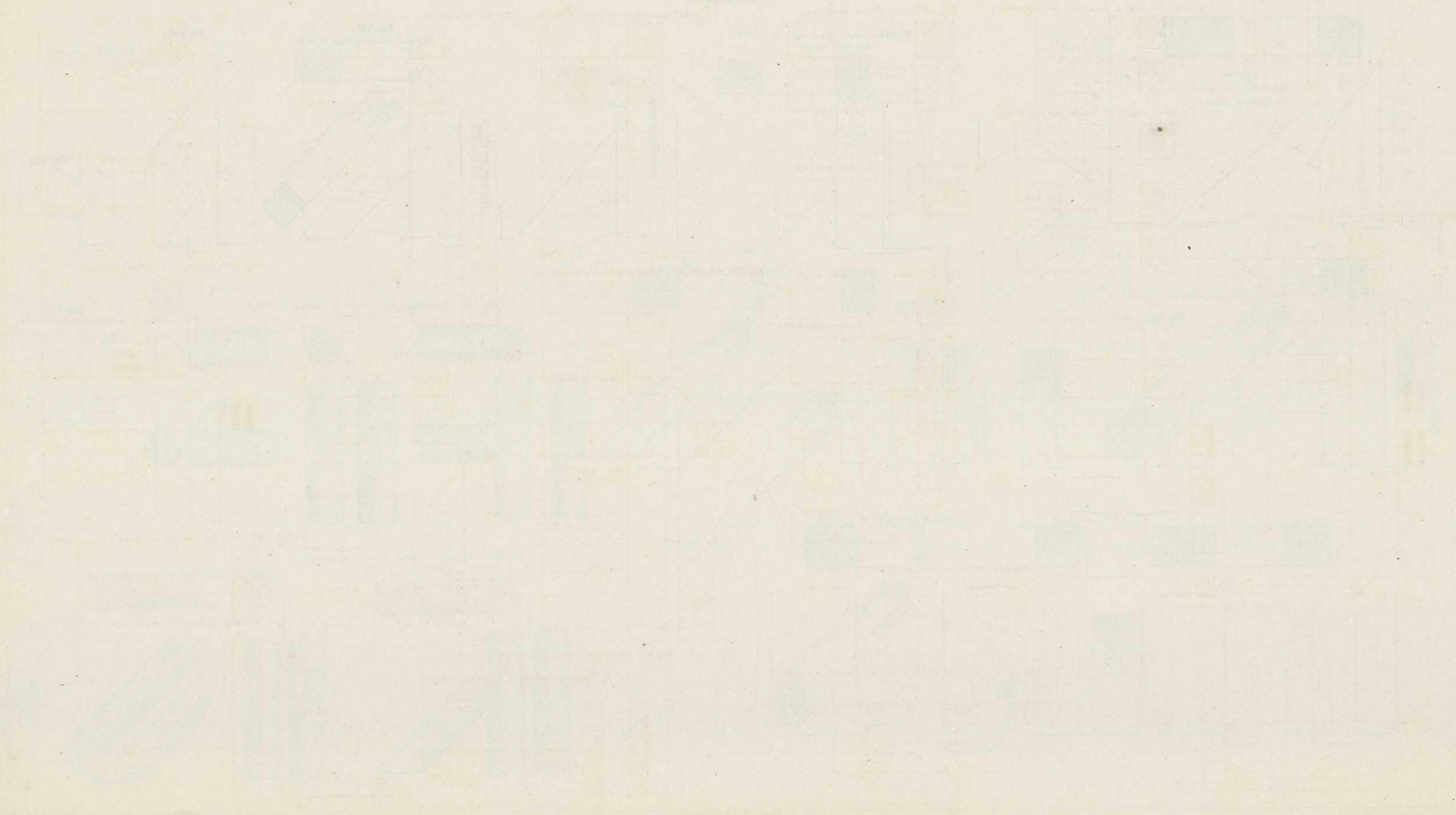




PLATE I





ART DU CHARPENTIER

Assemblages.

Fig. 455. Assemblage à outice avec emboîtement.

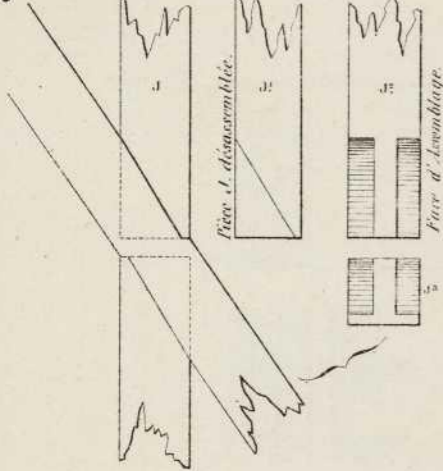


Fig. 462. Assemblage à tenon avec renfort en chaperon.

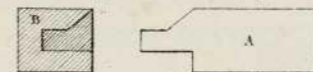


Fig. 464. Assemblage à tenon avec renfort carré.

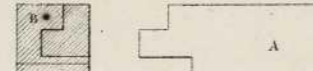


Fig. 465.

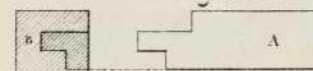


Fig. 466. Assemblage avec tenon à chaperon et renfort.

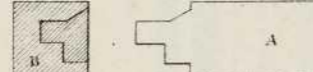


Fig. 461. Assemblage à paume.

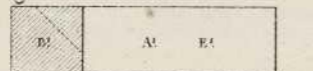


Fig. 467. Assemblage à double repos.

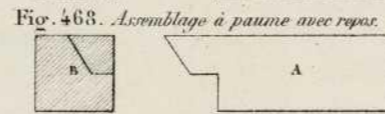
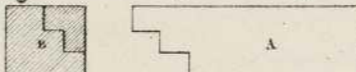


Fig. 469. Assemblage à double paume avec repos.

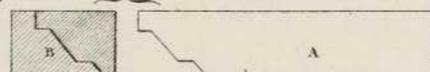


Fig. 470. Assemblage à entaille carrée.

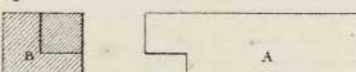


Fig. 471. Assemblage à mors d'âne.



Fig. 472. Assemblages à tenons en biseau.

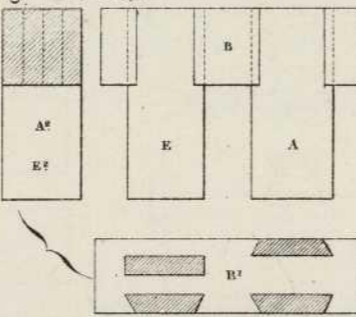


Fig. 474. Assemblages à tenons passants et apparents.

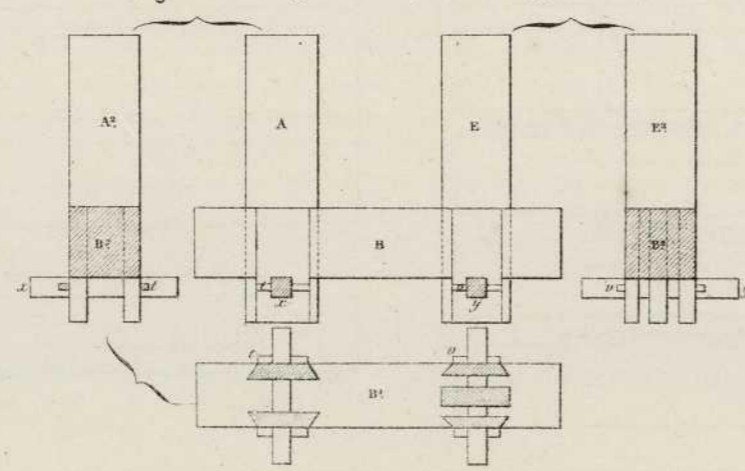


Fig. 477. Assemblages en queue d'hironde.

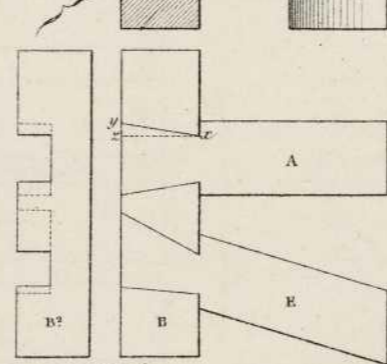
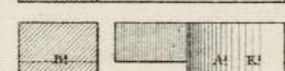
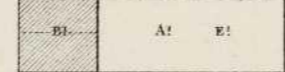


Fig. 478. Assemblages en queue d'hironde à recouvrement.

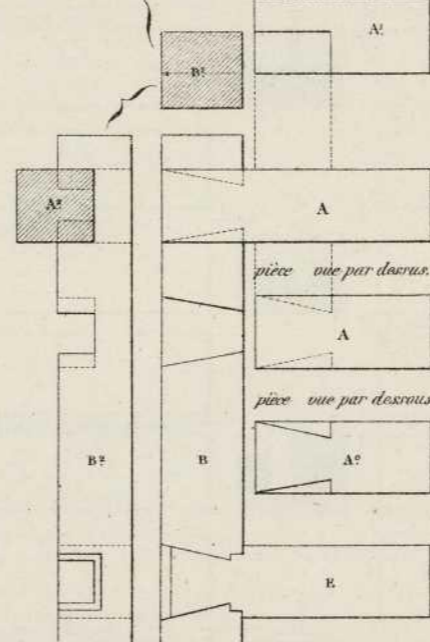
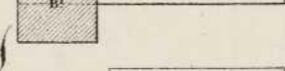
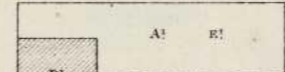


Fig. 479. Assemblages à queue d'hironde à clef.

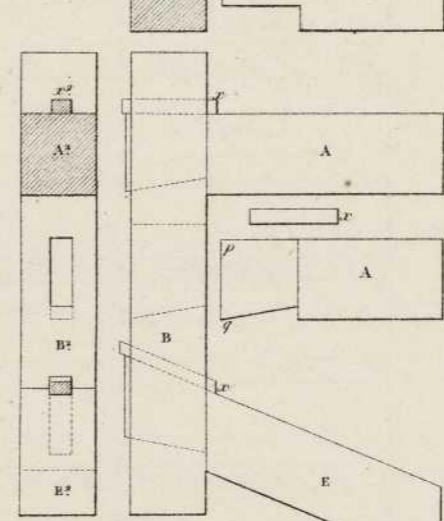
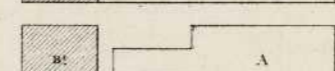
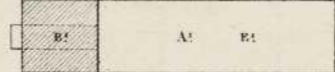


Fig. 480. Assemblages par simple entaille à mi-bois.

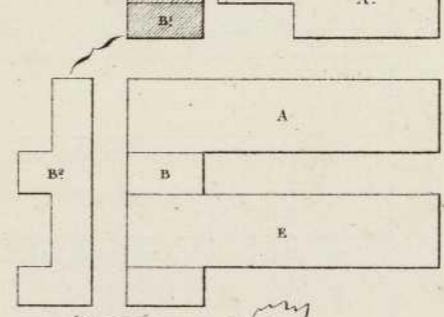
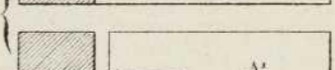
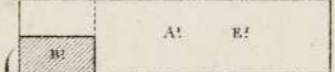


Fig. 476. Assemblages au moyen de courbes.

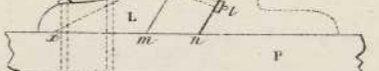


Fig. 475. Assemblage à tenons et mortaise sur l'arête.

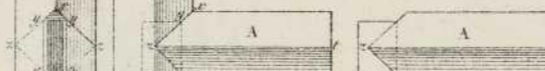
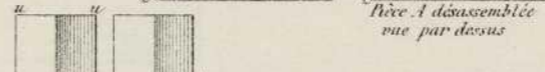


Fig. 481. Assemblages à onglets.

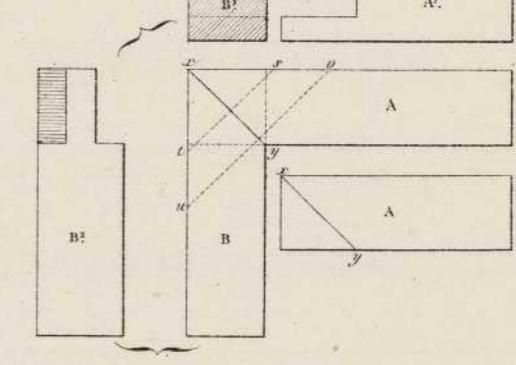
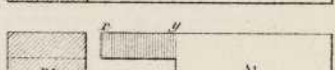
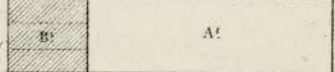


Fig. 482. Assemblage à onglets avec tenons.

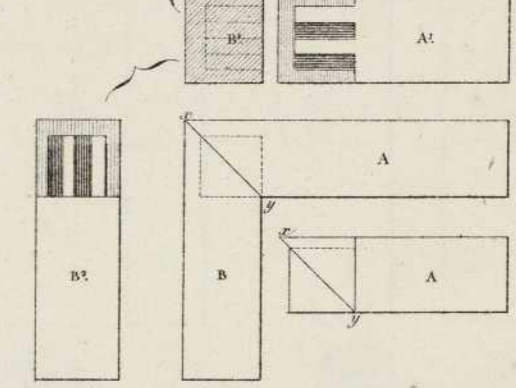
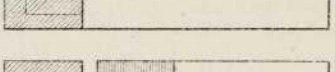
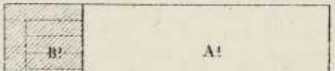
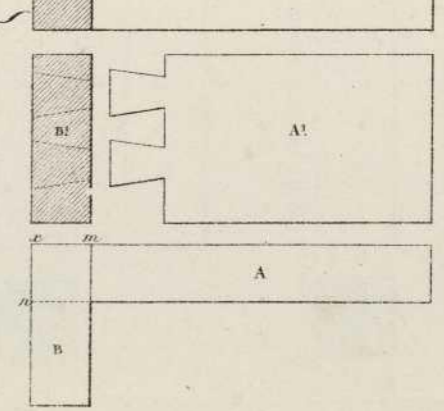
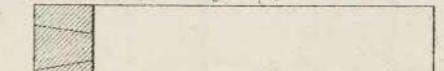
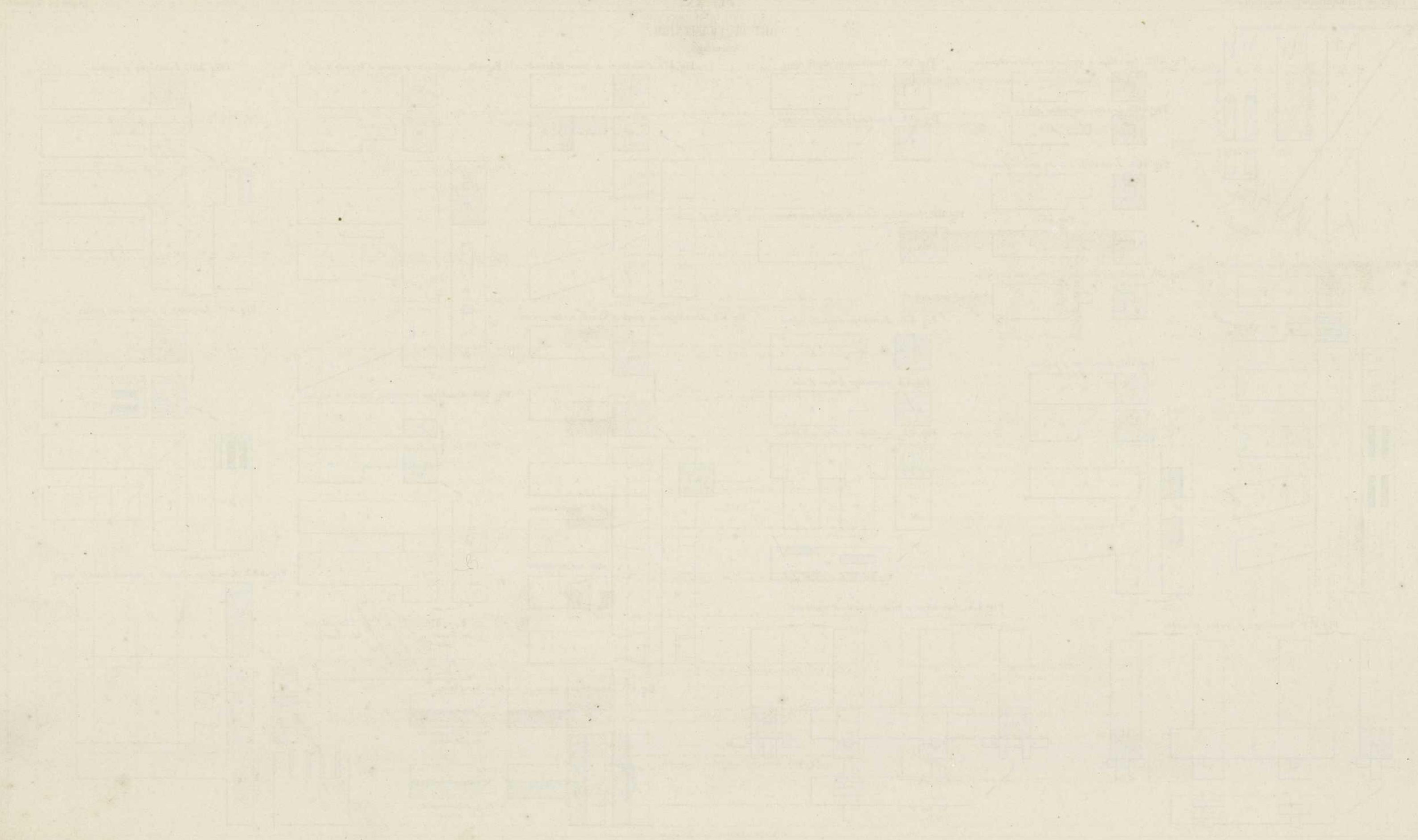


Fig. 483. Assemblage d'angle à queue d'hironde simple.









ART DU CHARPENTIER.  
Assemblages.

Fig. 484. Assemblage d'angle à queue d'hironde à recour.

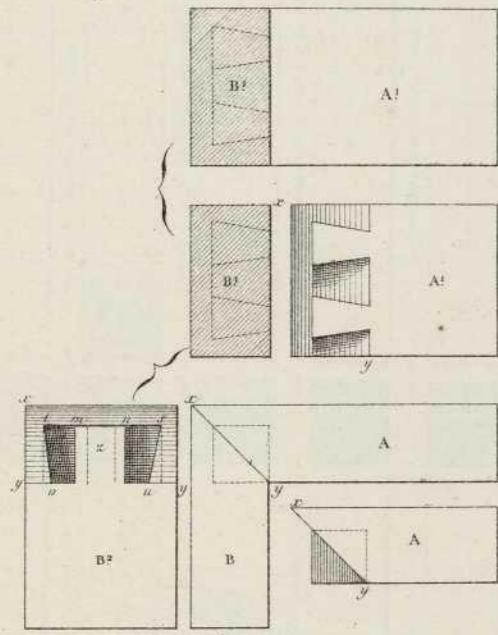


Fig. 486. Assemblage à tenon avec recour en angle double.

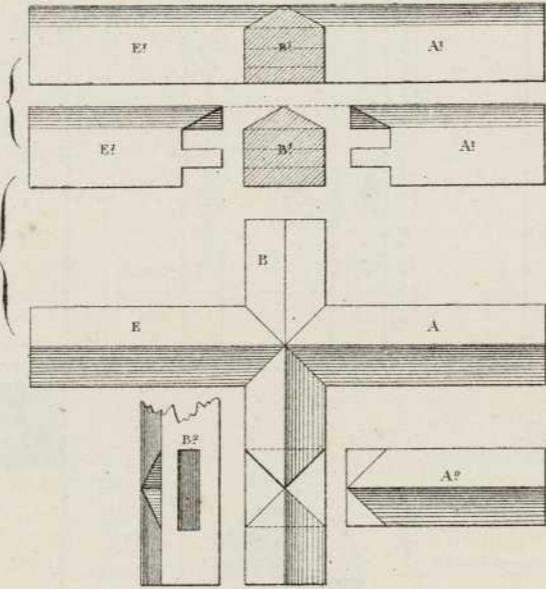


Fig. 490. Enture à mi-bois avec tenons d'about.

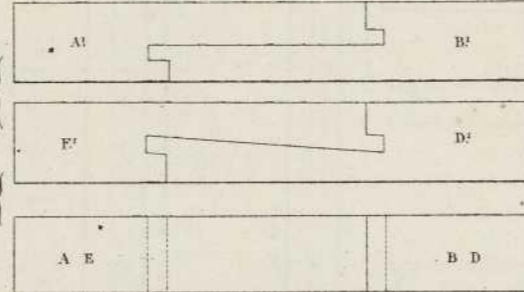


Fig. 491. Enture à mi-bois avec abouts en coupe.

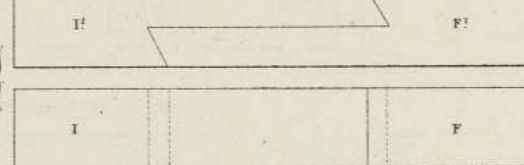


Fig. 492. Enture à mi-bois avec abouts carrés et tenons.

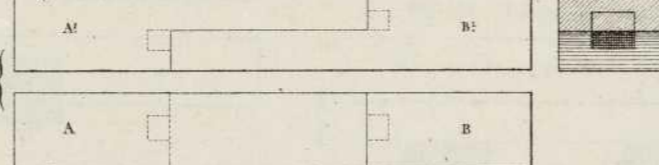


Fig. 493. idem avec abouts en coupe et brisés.

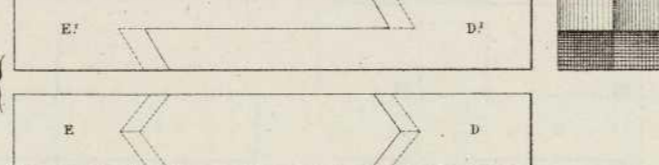


Fig. 494. idem avec rainures et languettes intérieures.

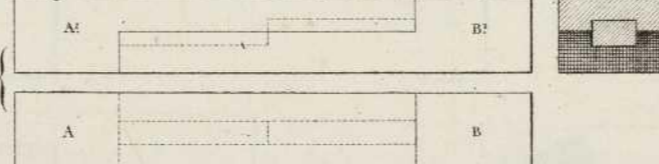


Fig. 495. Enture en fausses coupes avec tenons inverses, abouts en coupe et brisés.

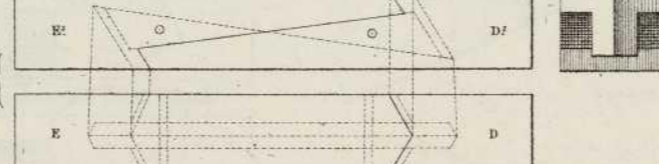


Fig. 496. Enture à coalisre en queue d'hironde.

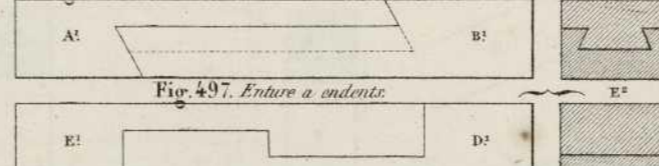


Fig. 497. Enture à endents.

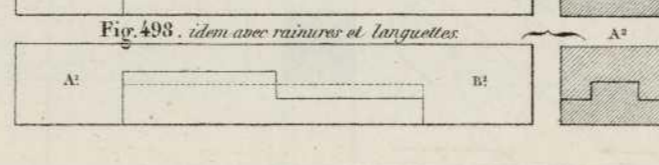


Fig. 498. idem avec rainures et languettes.

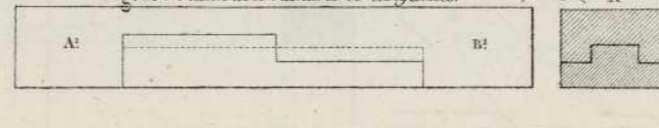


Fig. 500. Enture à endents en queue d'hironde avec coupes brisées.

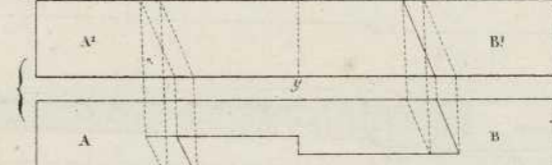


Fig. 501. Trait de Jupiter simple.

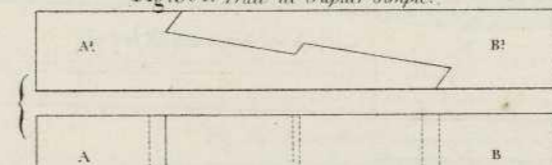


Fig. 502. Trait de Jupiter avec clef.

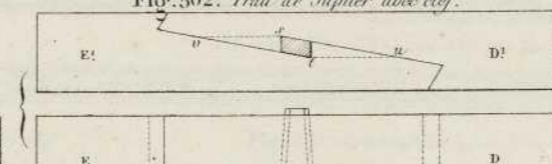


Fig. 503. idem avec abouts en coupe et brisés.

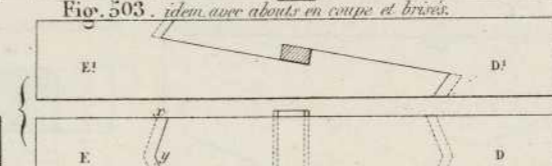


Fig. 504. à joints droits.

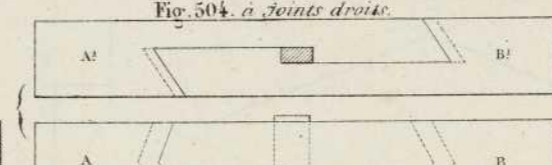


Fig. 505. idem avec tenons rainurés, languettes et clef.

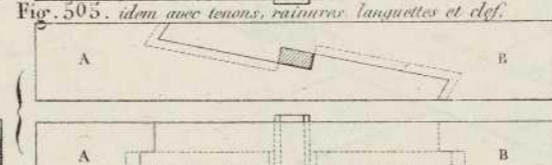


Fig. 506. idem à triple entaille et trois clefs.

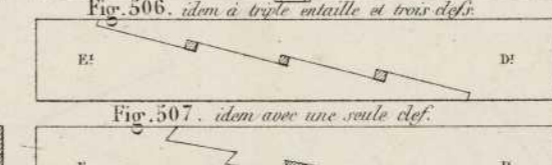


Fig. 507. idem avec une seule clef.

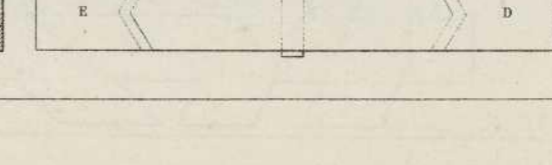
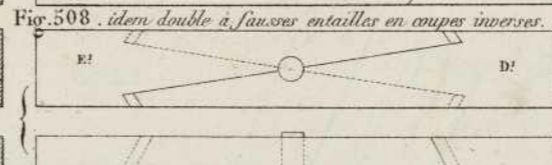


Fig. 508. idem double à fausses entailles en coupes inverses.

Fig. 509. Trait de Jupiter avec coupes droites et clef en queue d'hironde.

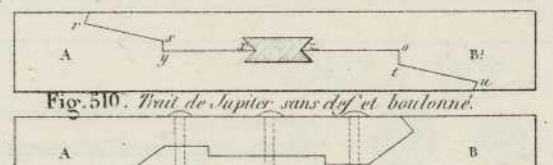


Fig. 510. Trait de Jupiter sans clef et boulonné.



Fig. 511. idem à joint droit avec une seule clef.

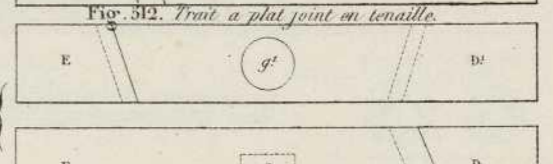


Fig. 512. Trait à plat joint ou tenaille.

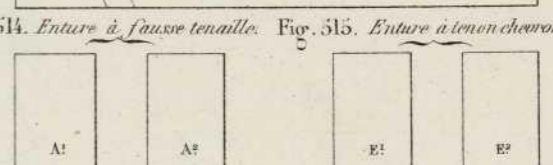


Fig. 514. Enture à fausse tenaille. Fig. 515. Enture à tenon chevronné.

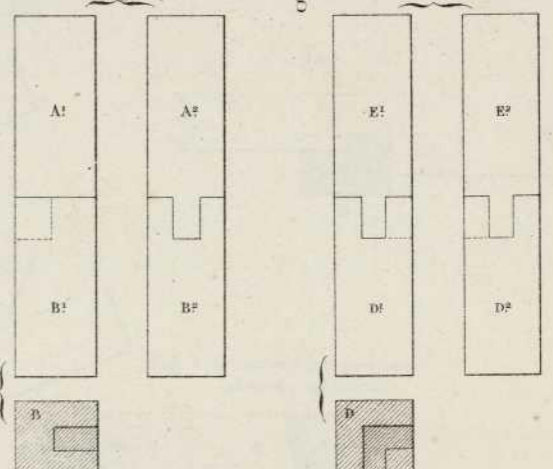


Fig. 516. Enture à tenons à croix.

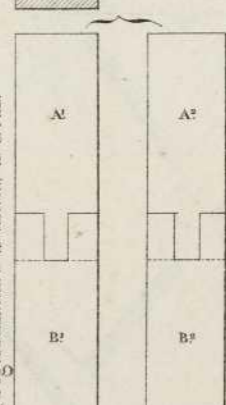
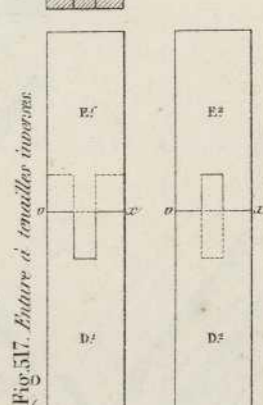


Fig. 517. Enture à tenailles inverses.





ARTZTUNGEN




ART DU CHARPENTIER

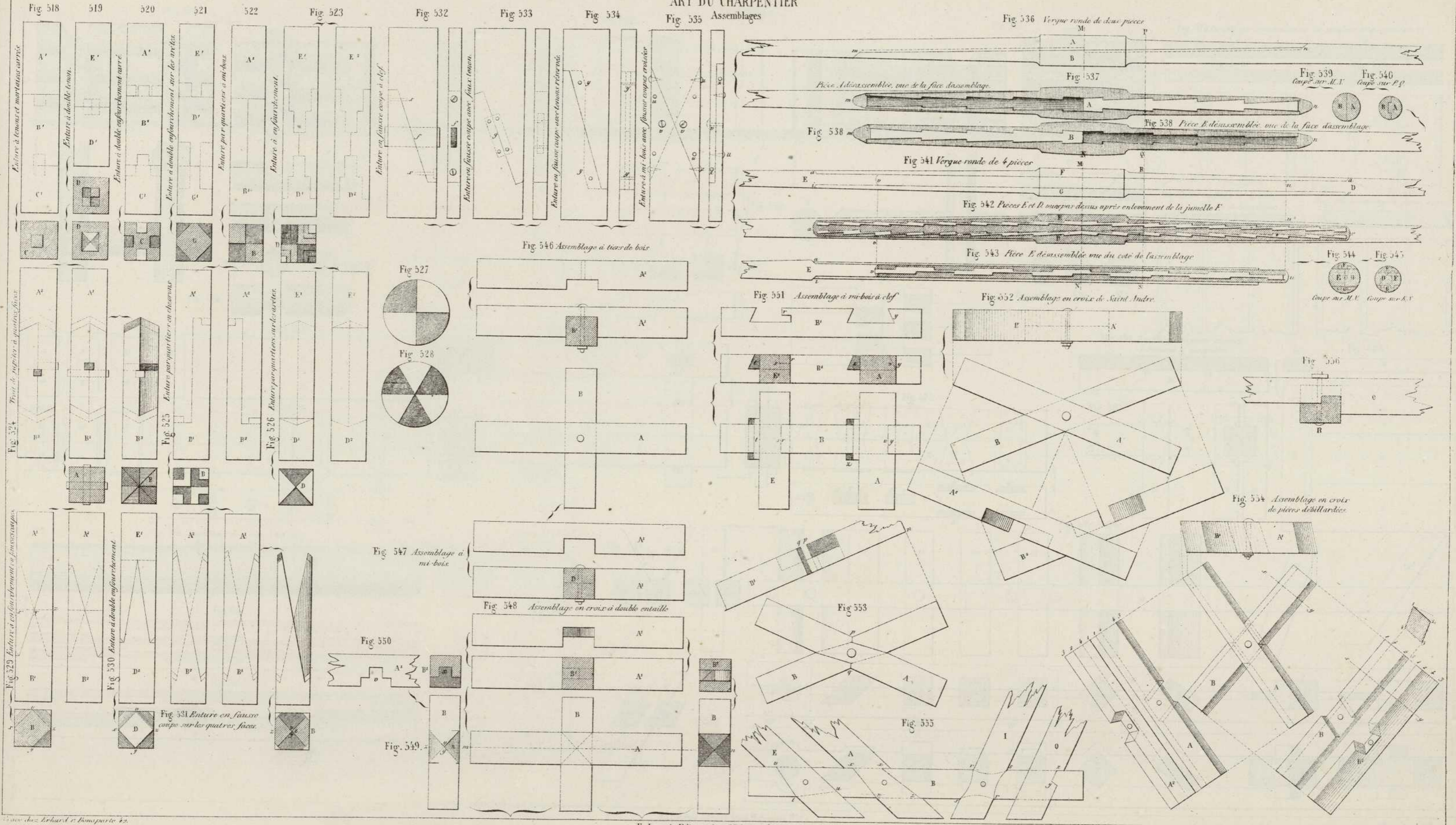


Fig. 518 Enture à tenon et mortaise carrée.

Fig. 519 Enture à double tenon.

Fig. 520 Enture à double enfourchement carré.

Fig. 521 Enture à double enfourchement sur les arêtes.

Fig. 522 Enture par quarts à mi-bois.

Fig. 523 Enture à enfourchement.

Fig. 524 Enture en fausse coupe à clef.

Fig. 525 Enture en fausse coupe avec faux tenon.

Fig. 526 Enture en fausse coupe avec faux tenon reborné.

Fig. 527 Enture à mi-bois avec fausses coupes croisées.

Fig. 528 Enture à mi-bois avec fausses coupes croisées.

Fig. 529 Enture à enfourchement à travers bois.

Fig. 530 Enture à double enfourchement.

Fig. 531 Enture en fausse coupe sur les quatre faces.

Fig. 532 Assemblage à tiers de bois.

Fig. 533 Assemblage à mi-bois à clef.

Fig. 534 Assemblage en croix de Saint André.

Fig. 535 Assemblage en croix de pièces débillardées.

Fig. 536 Verge ronde de deux pièces.

Fig. 537 Pièce A démontée, vue de la face d'assemblage.

Fig. 538 Pièce B démontée, vue de la face d'assemblage.

Fig. 539 Coupe sur M.N.

Fig. 540 Coupe sur P.Q.

Fig. 541 Verge ronde de 4 pièces.

Fig. 542 Pièces E et D coupées dessus après enlèvement de la jumelle F.

Fig. 543 Pièce E démontée, vue du côté de l'assemblage.

Fig. 544 Coupe sur M.N.

Fig. 545 Coupe sur A.V.

Fig. 546 Assemblage à mi-bois.

Fig. 547 Assemblage à mi-bois.

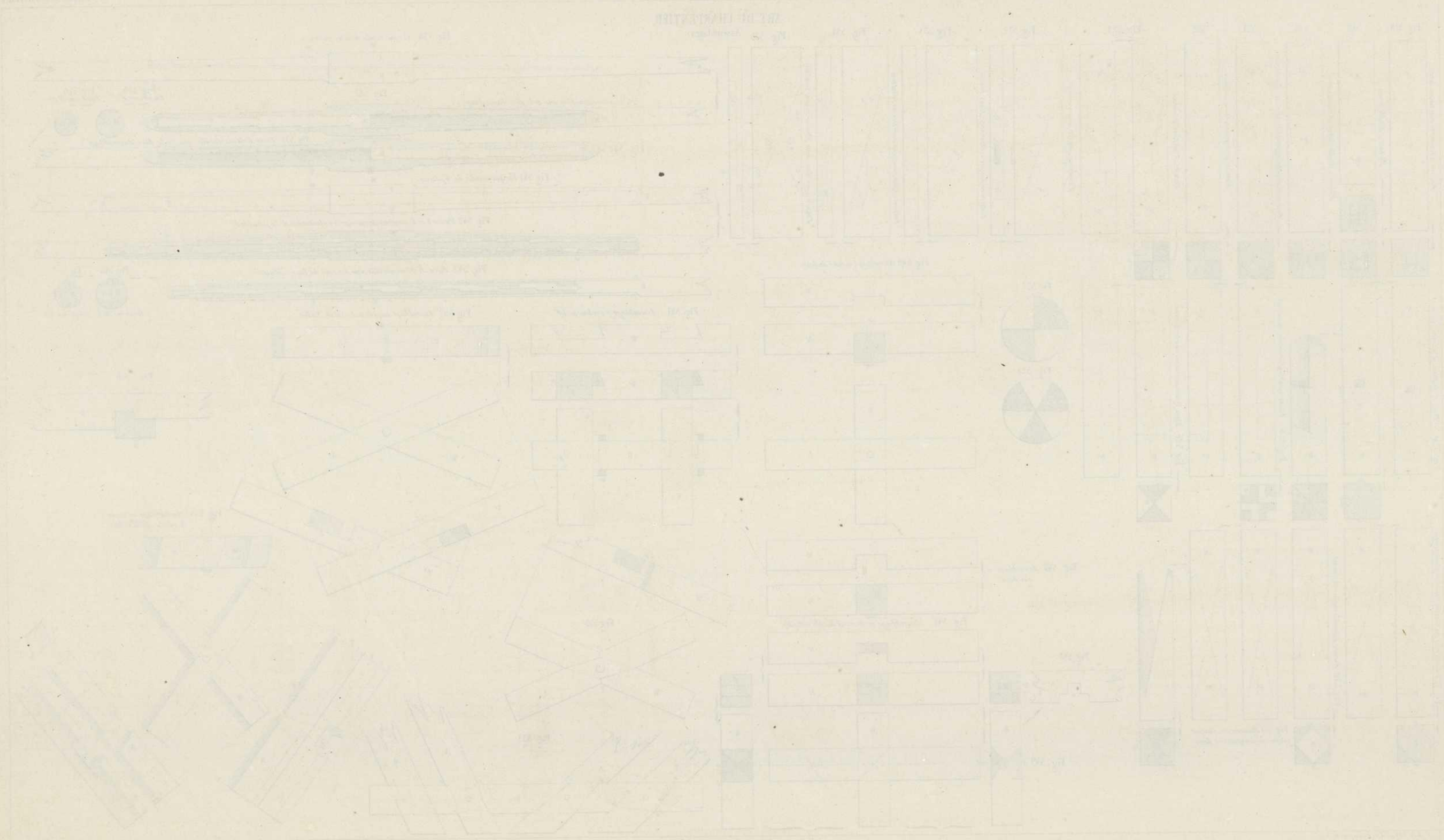
Fig. 548 Assemblage en croix à double entaille.

Fig. 549 Assemblage en croix à double entaille.

Paris chez Leclercq et Compagnie 1822.



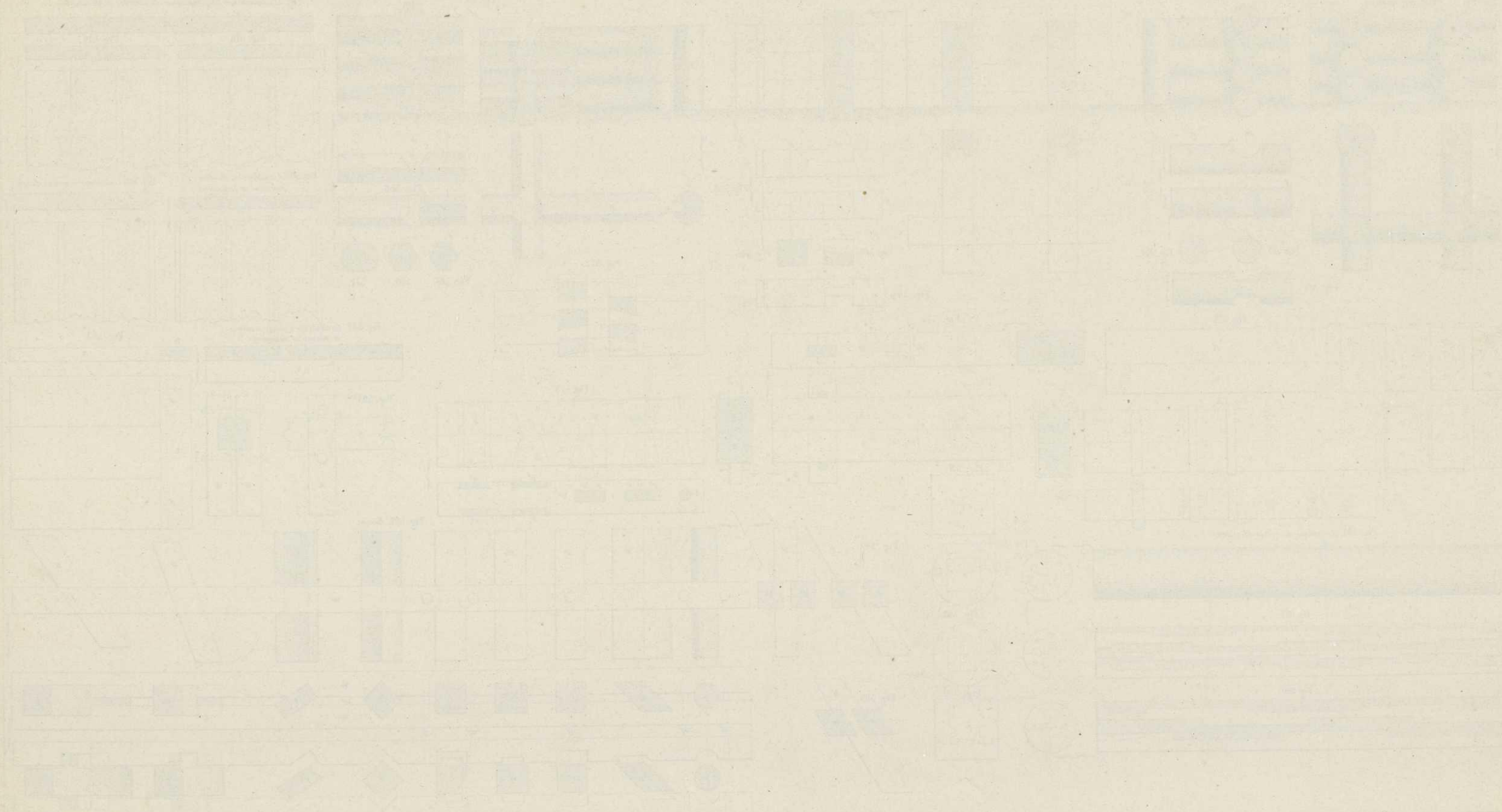
THE GREAT TEMPLE









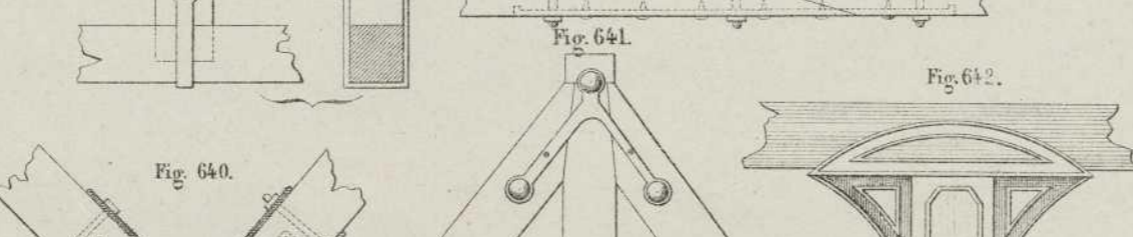
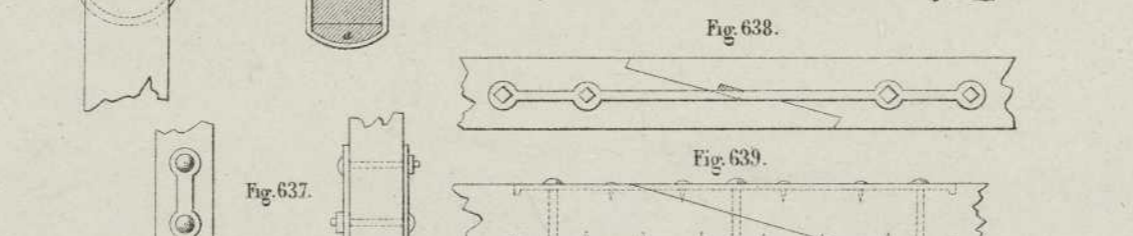
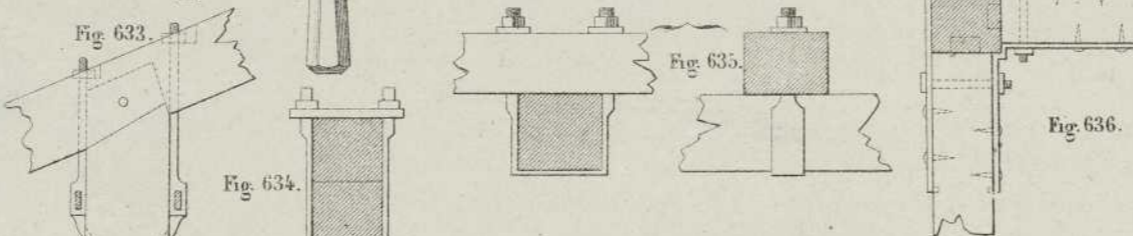
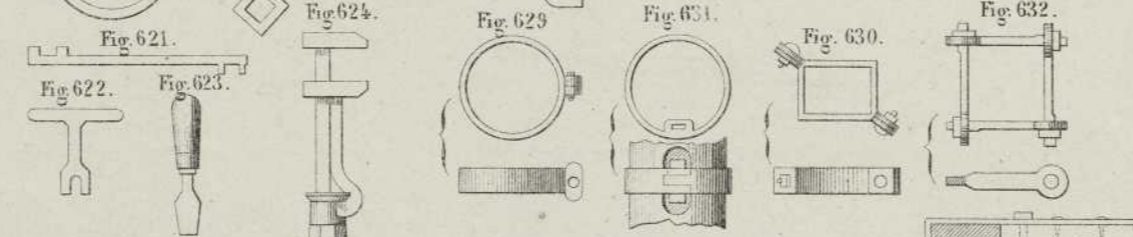
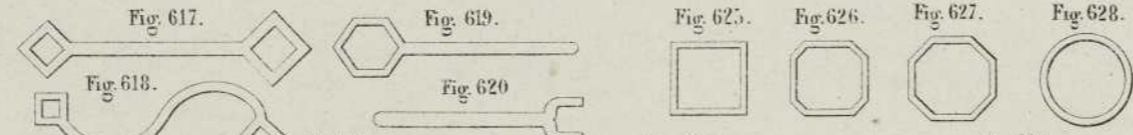
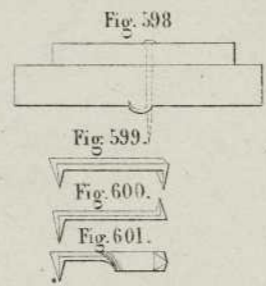
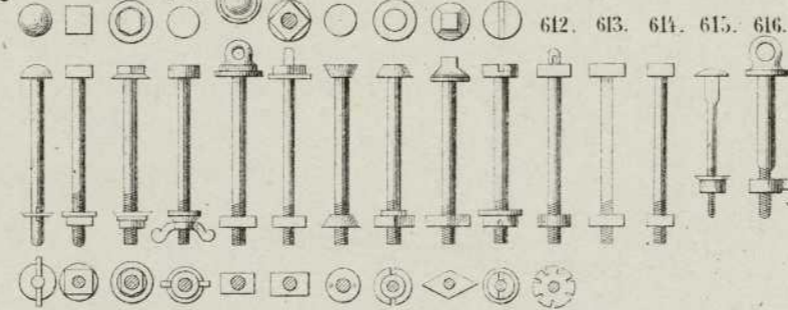




ART DU CHARPENTIER.

Emploi du fer dans les Charpentes.

Fig<sup>s</sup> 602. 603. 604. 605. 606. 607. 608. 609. 610. 611.



Assemblages.

Fig. 594.

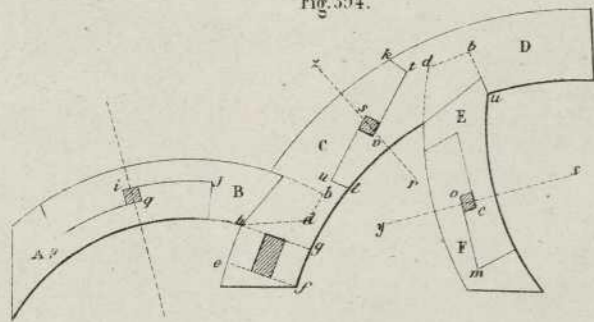


Fig. 595.

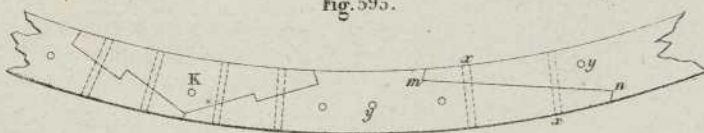


Fig. 596.

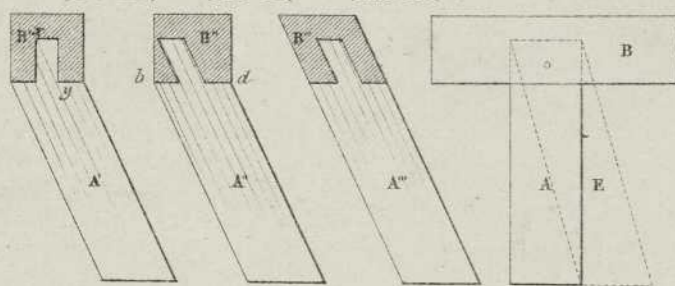
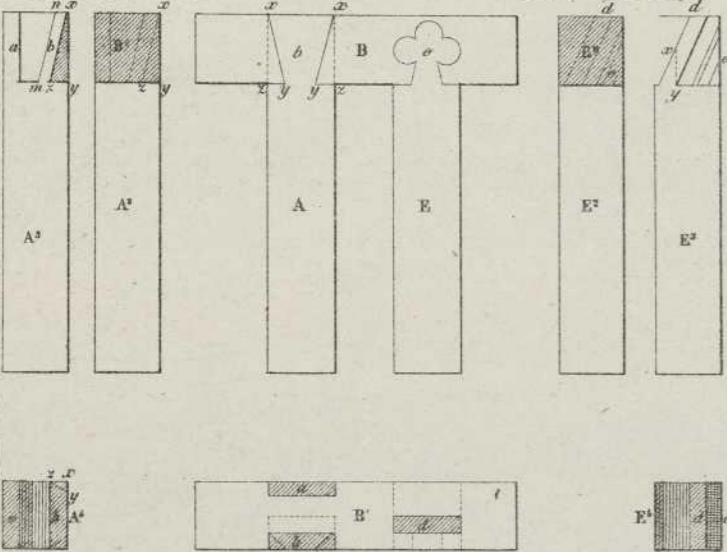


Fig. 597.



Courbure des bois

Fig. 645.

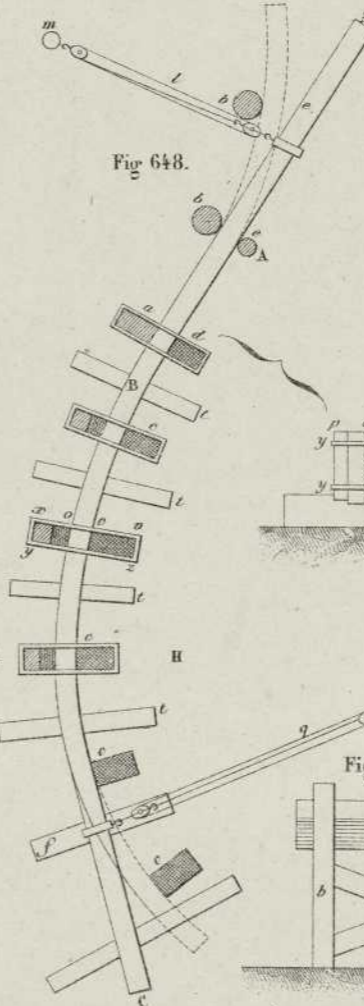
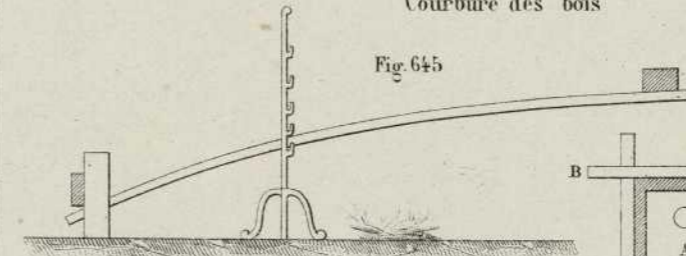


Fig. 648.

Fig. 649.

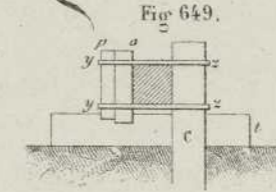


Fig. 651.

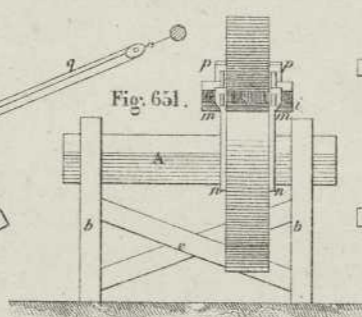


Fig. 650.

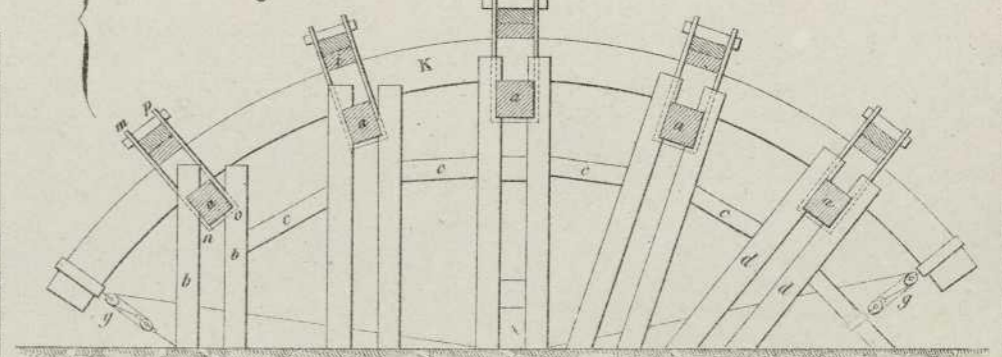


Fig. 647.

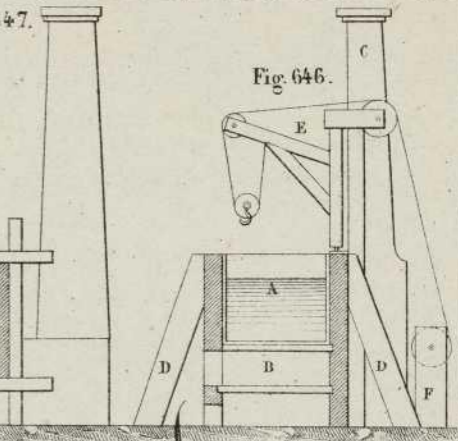
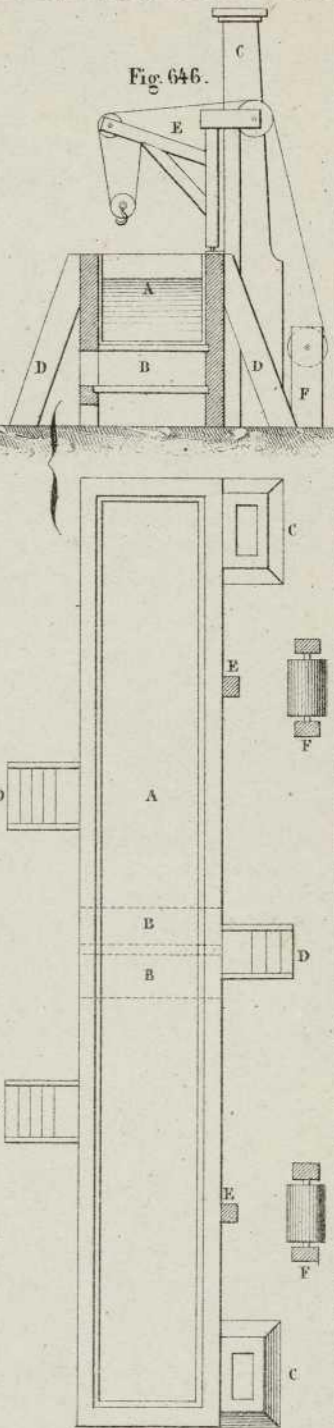
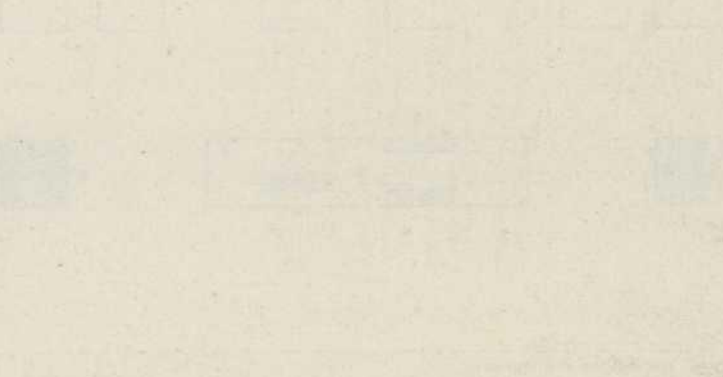
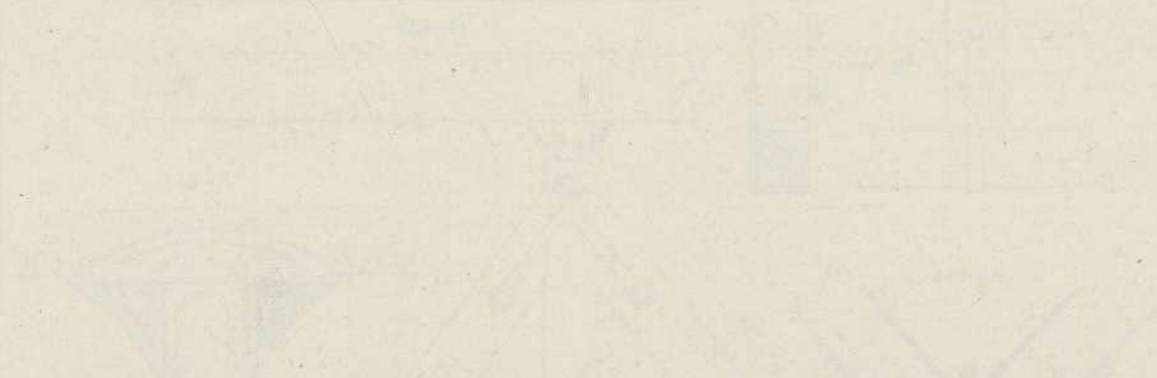
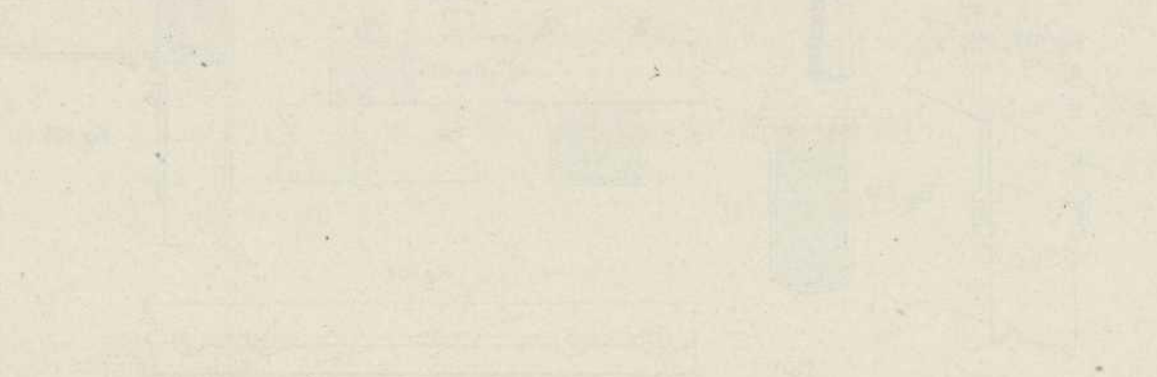
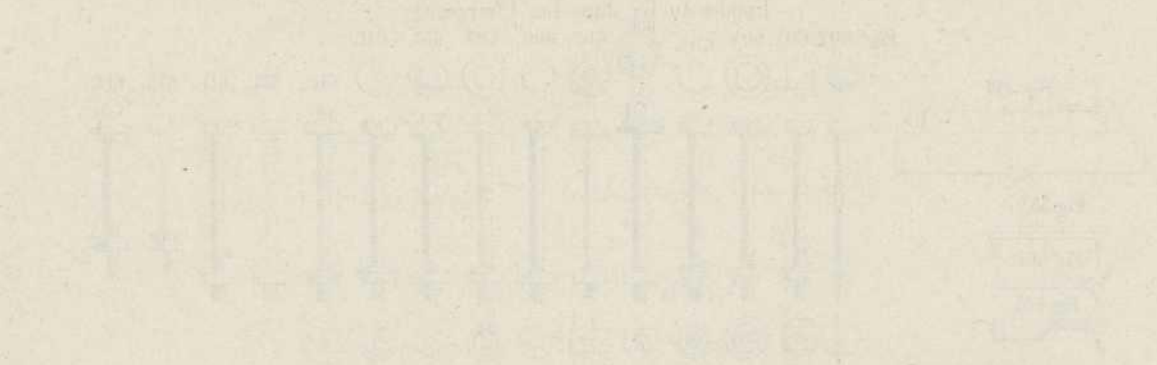


Fig. 646.



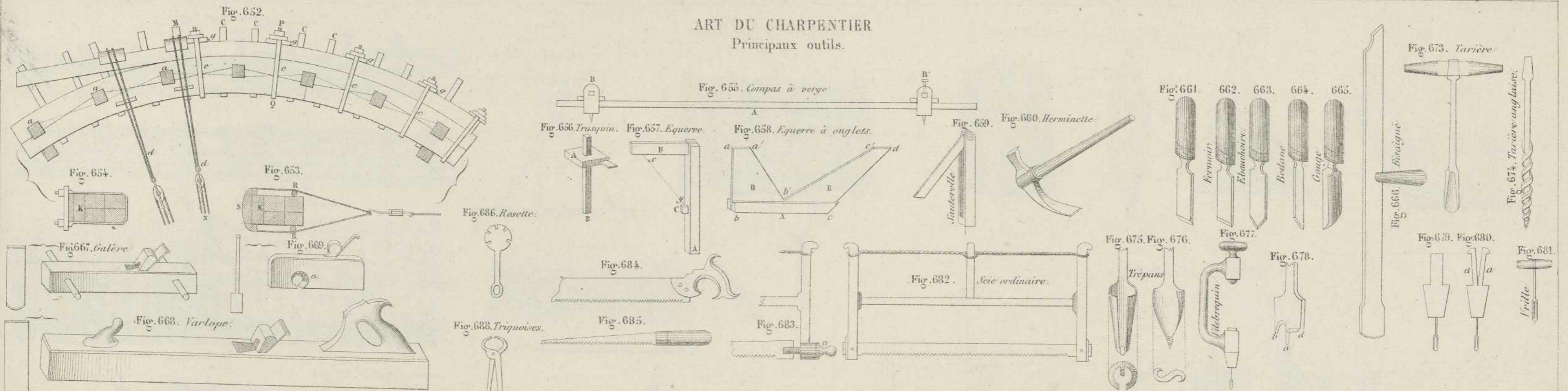


STANDARD

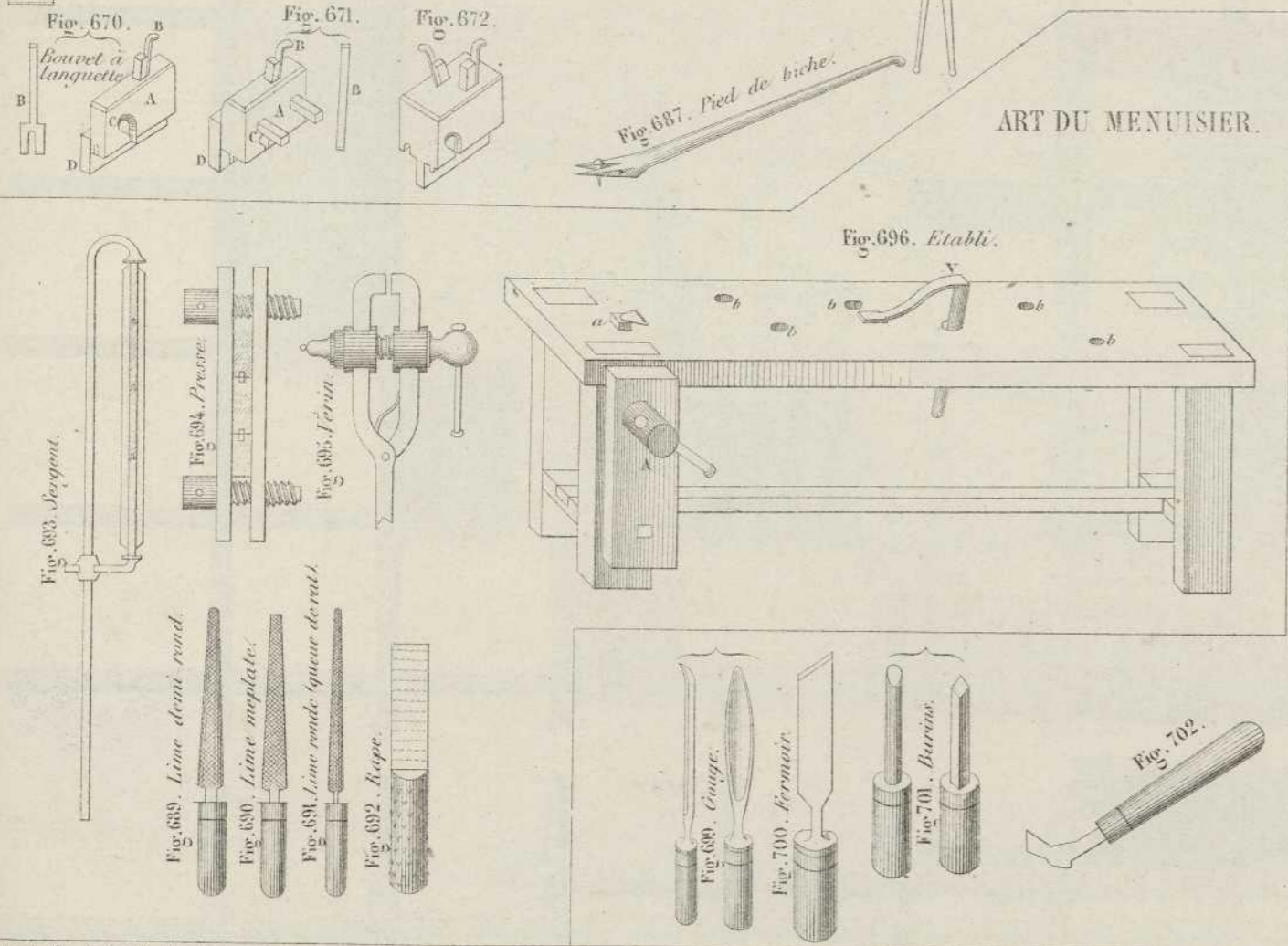




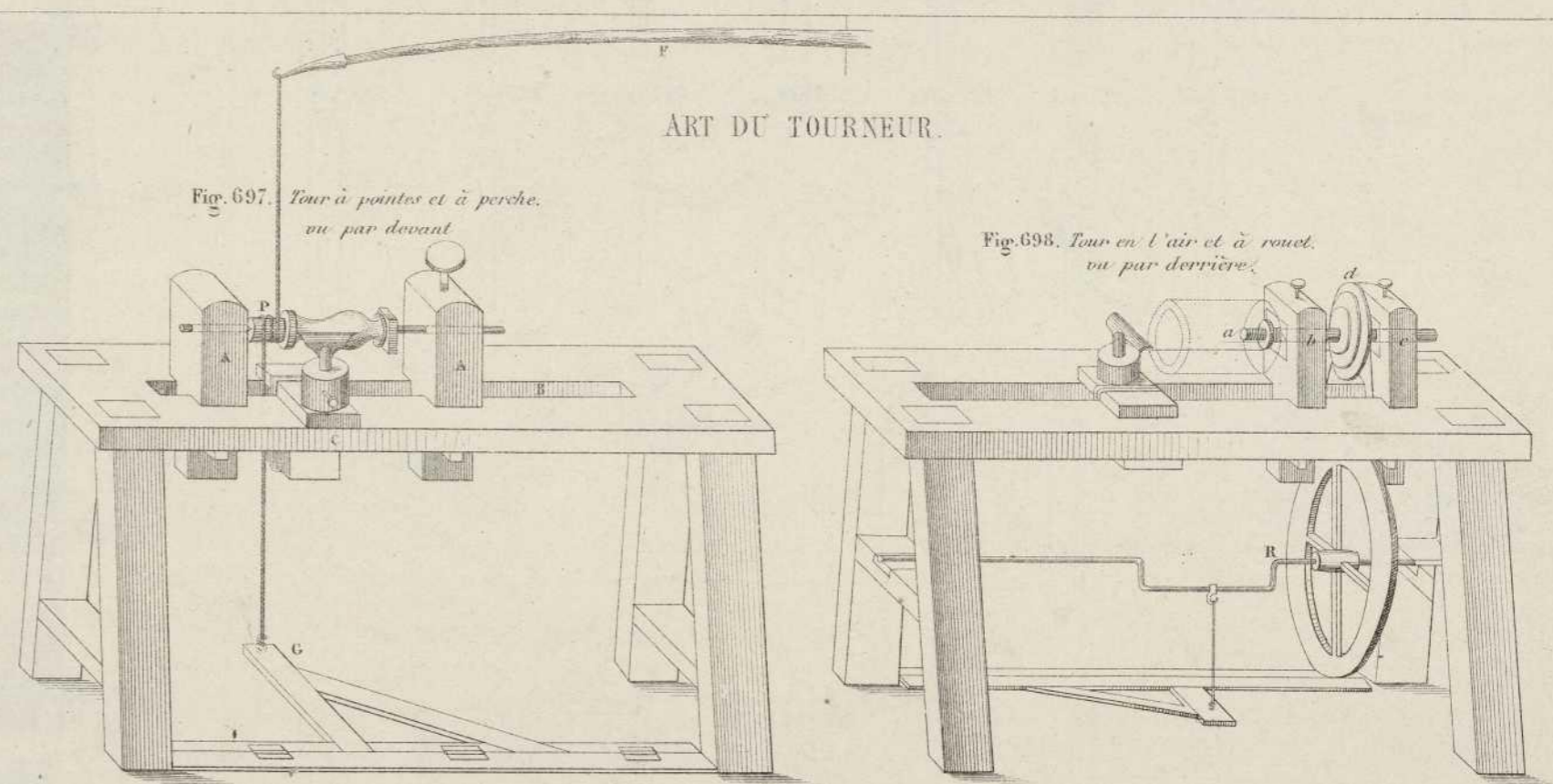
ART DU CHARPENTIER  
Principaux outils.



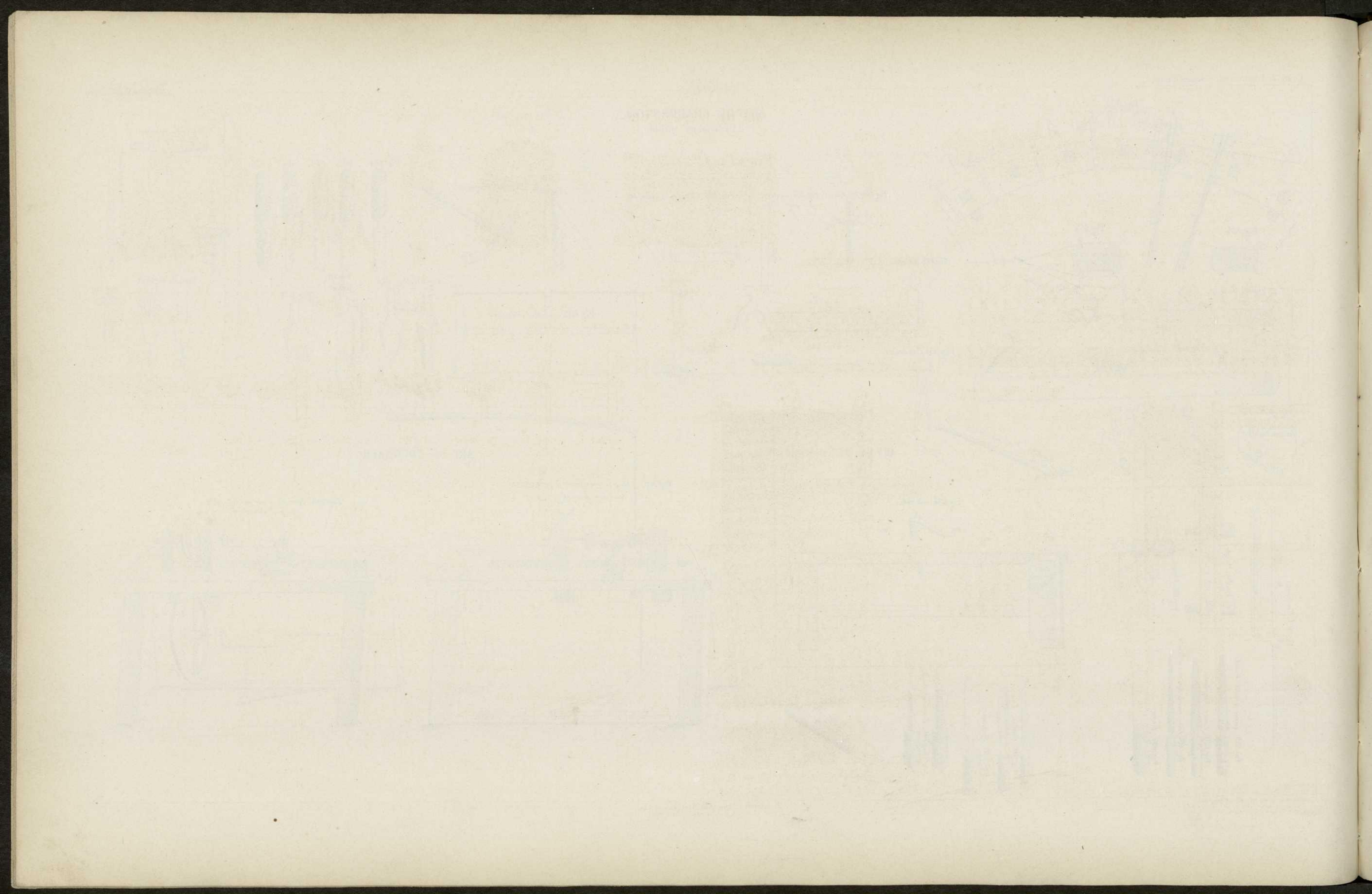
ART DU MENUISIER.



ART DU TOURNEUR.









ART DU FASCINEUR.

Fig. 709. Clayonnage.

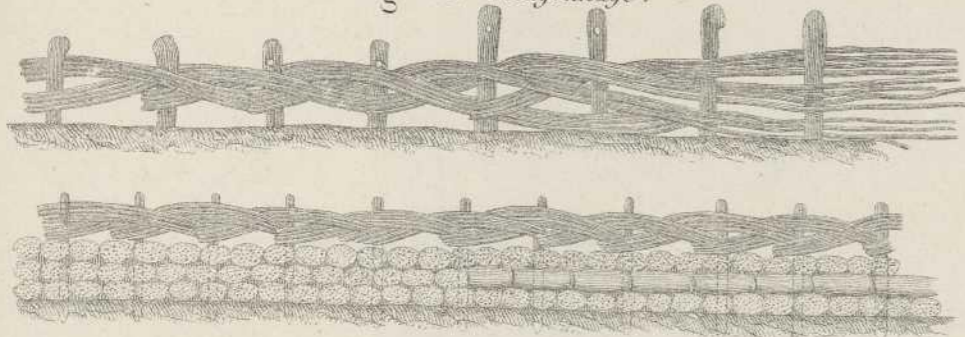


Fig. 710. Fascinage et Tunage.

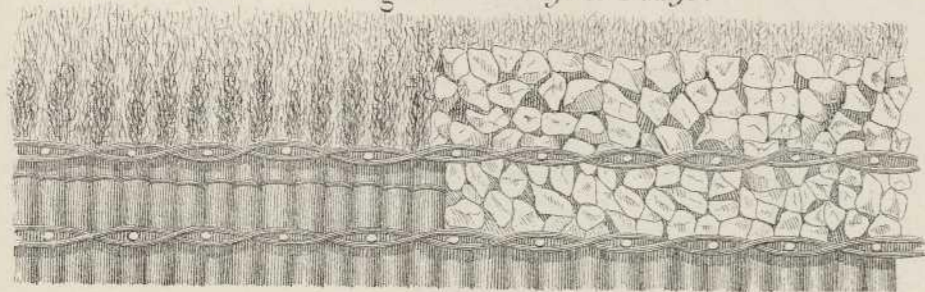


Fig. 711. Plate forme.

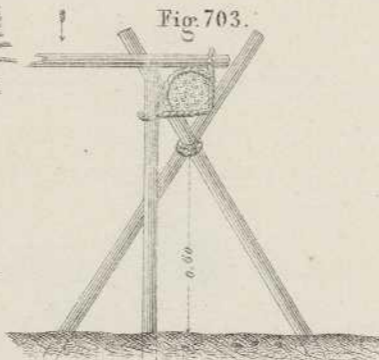
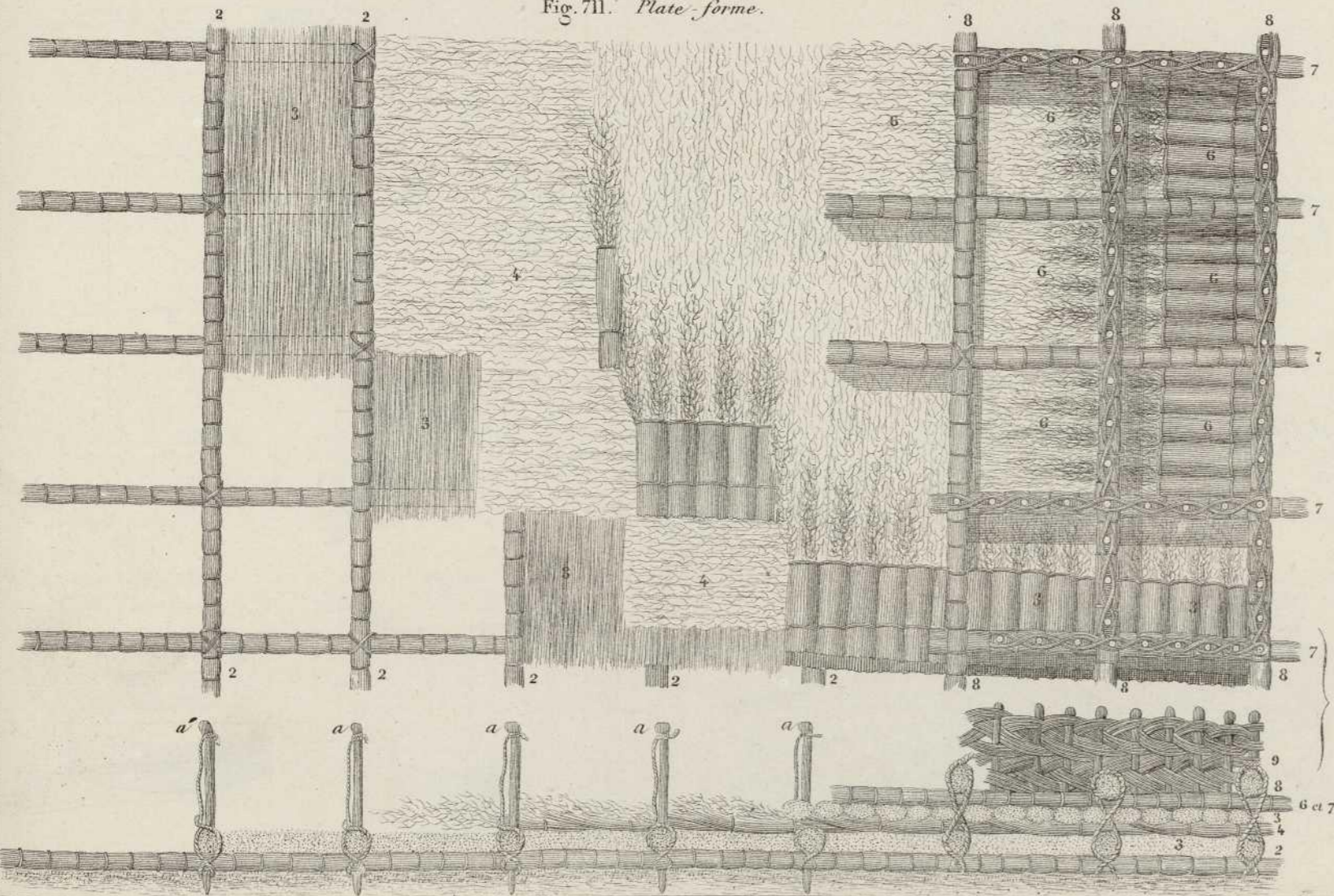


Fig. 712. Paillonnage

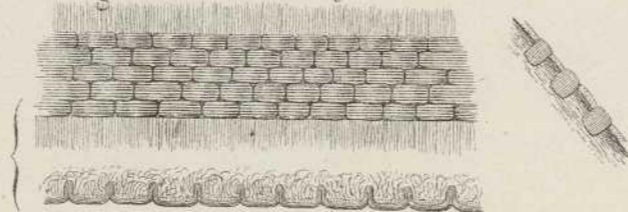


Fig. 704.

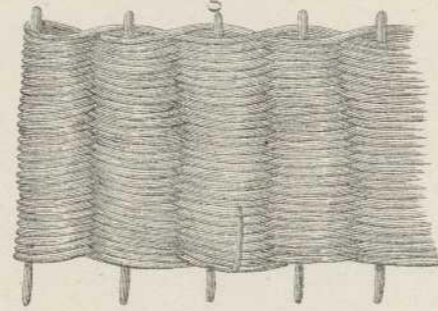


Fig. 713.

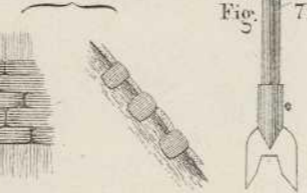


Fig. 705.



Fig. 706.

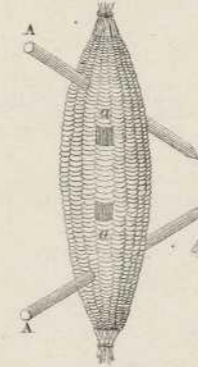


Fig. 707.

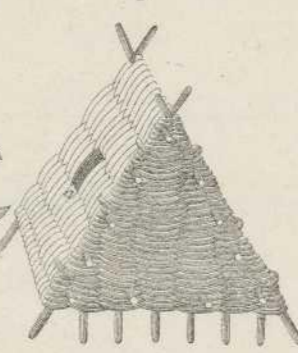
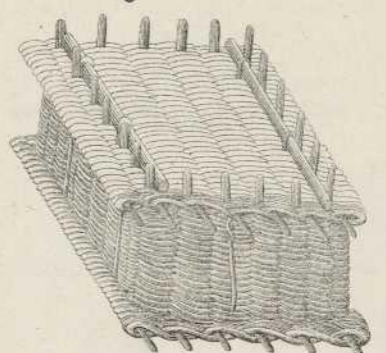
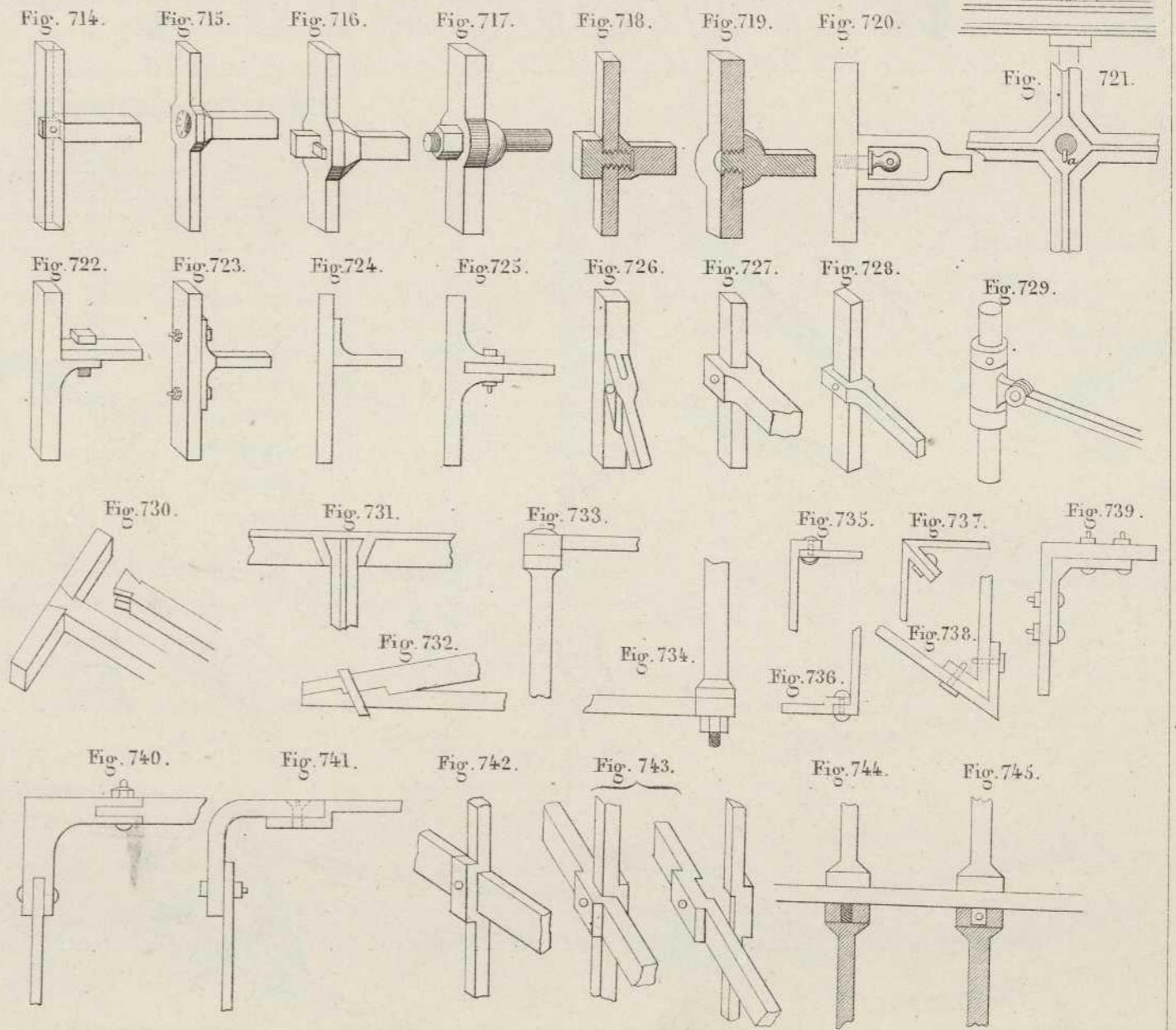


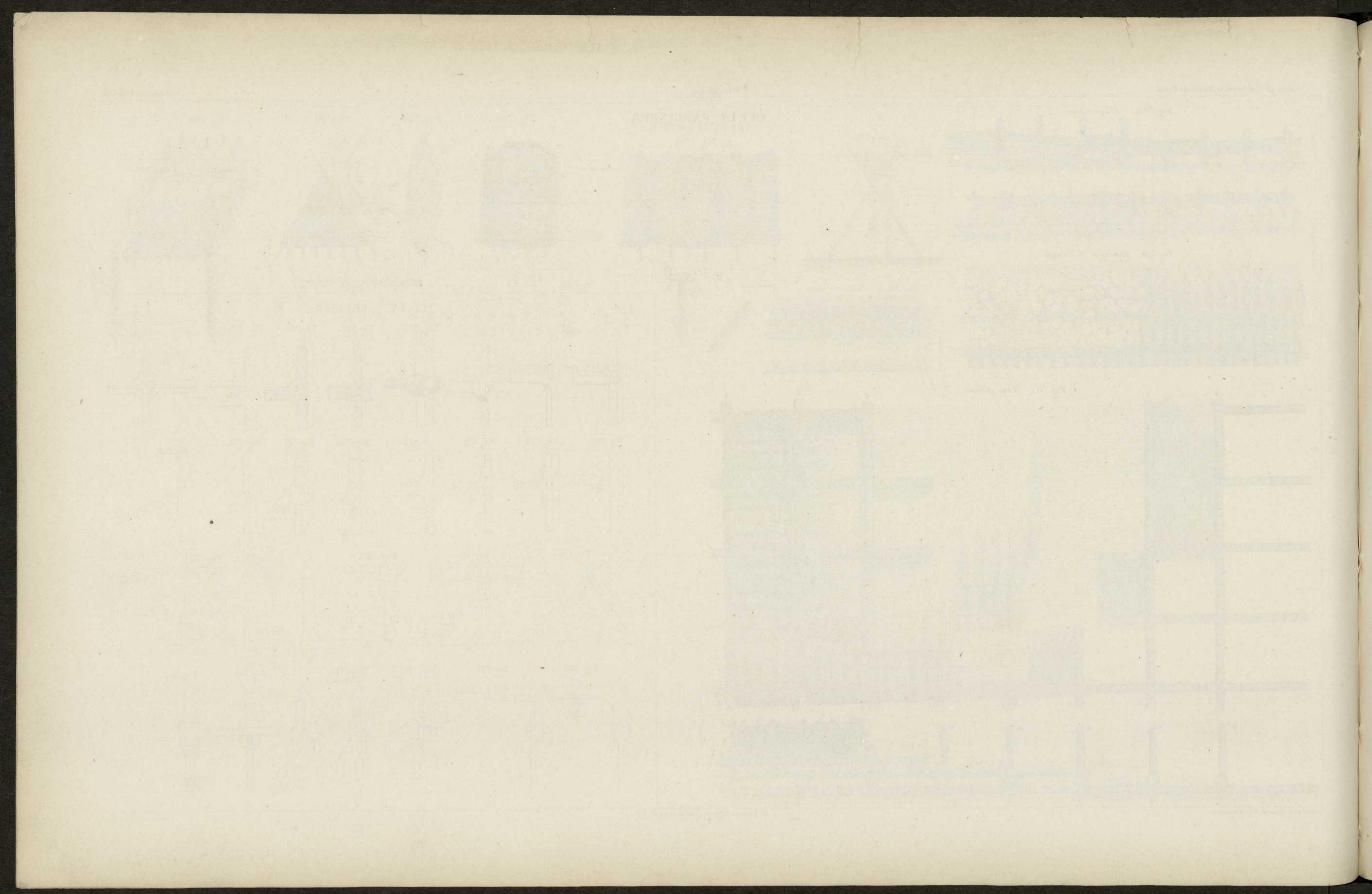
Fig. 708.



ART DU SERRURIER.

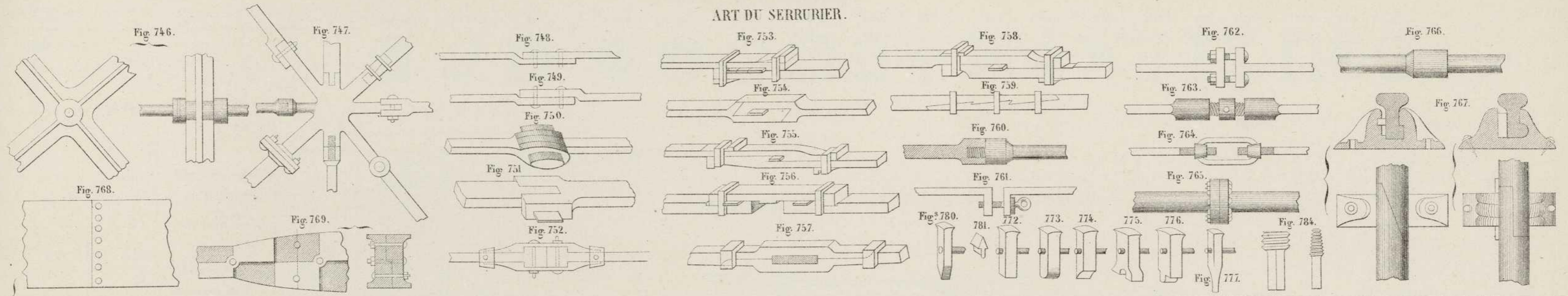




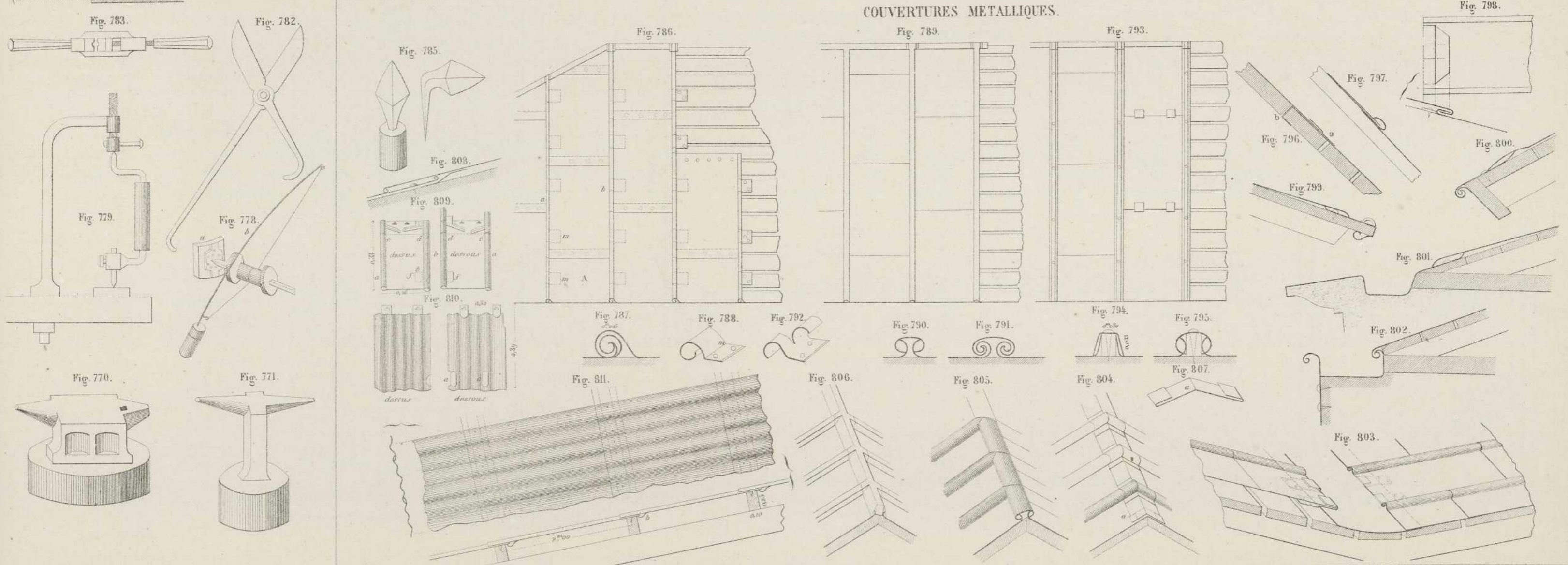




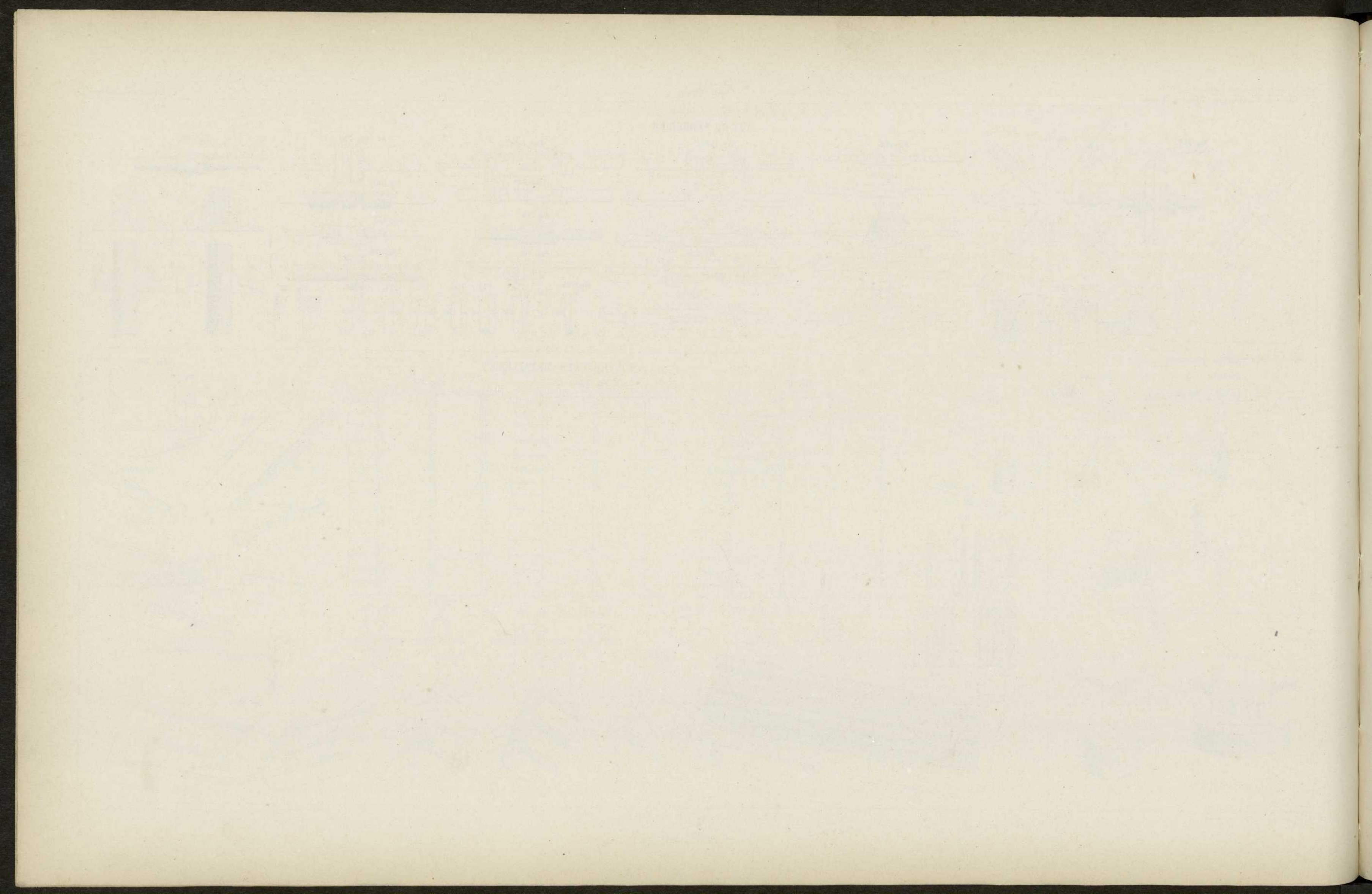
ART DU SERRURIER.



COUVERTURES METALLIQUES.

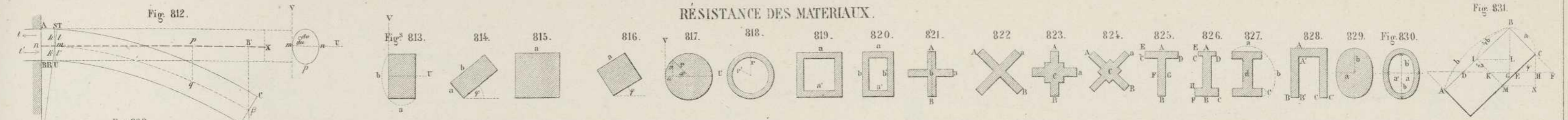




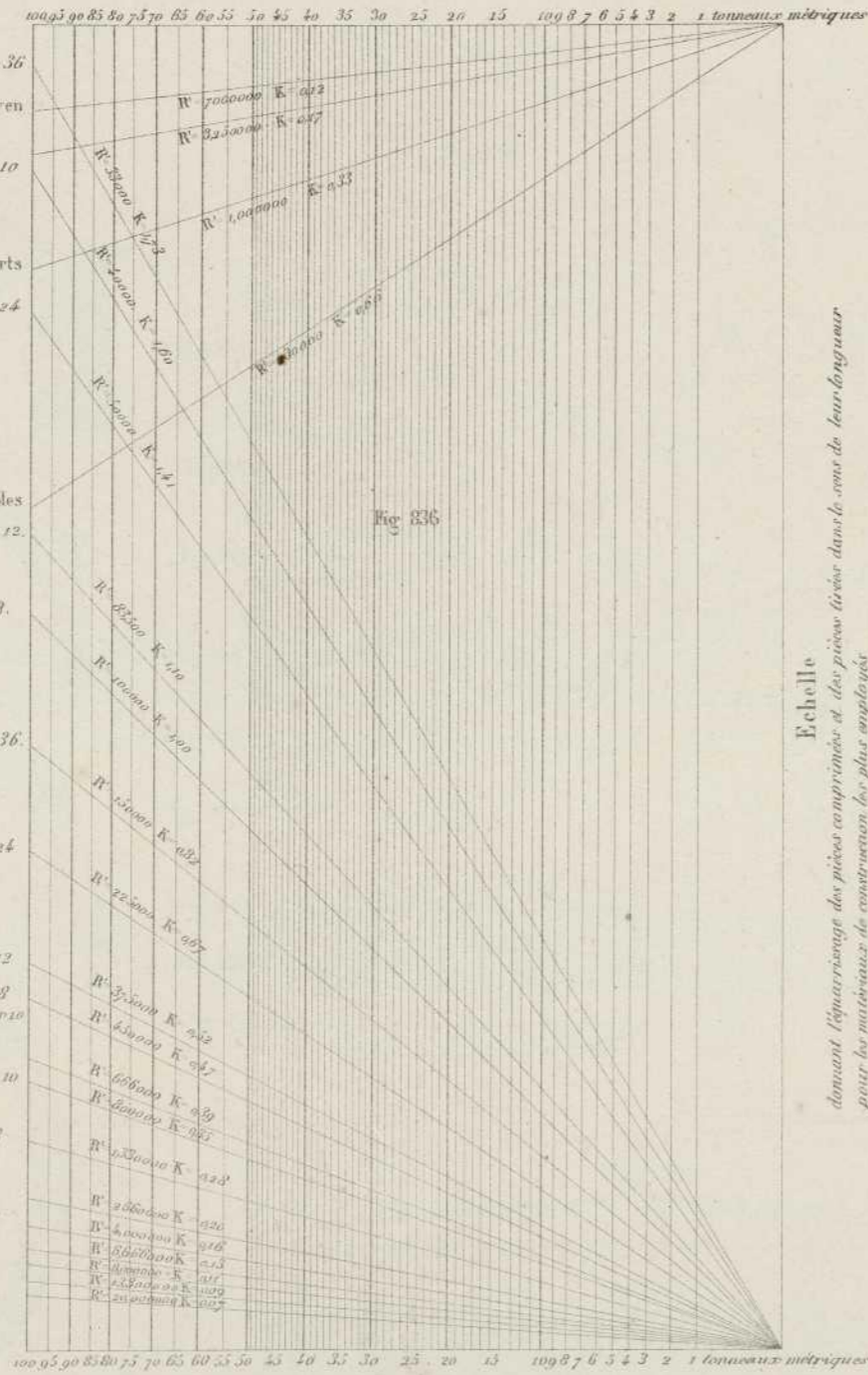




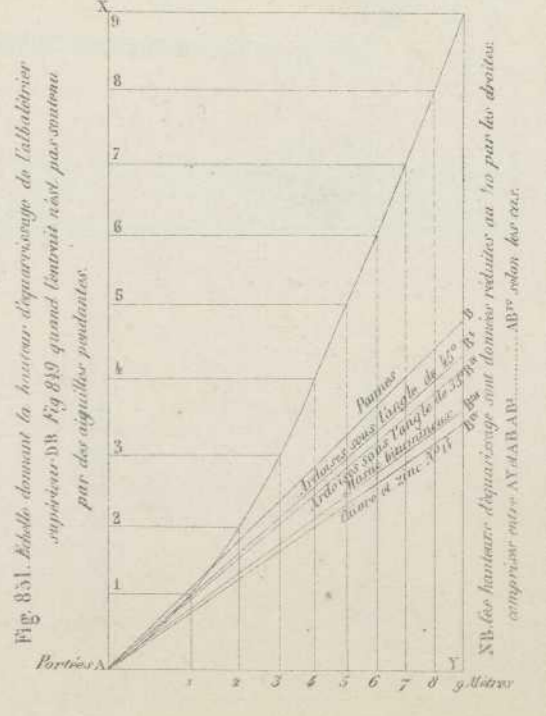
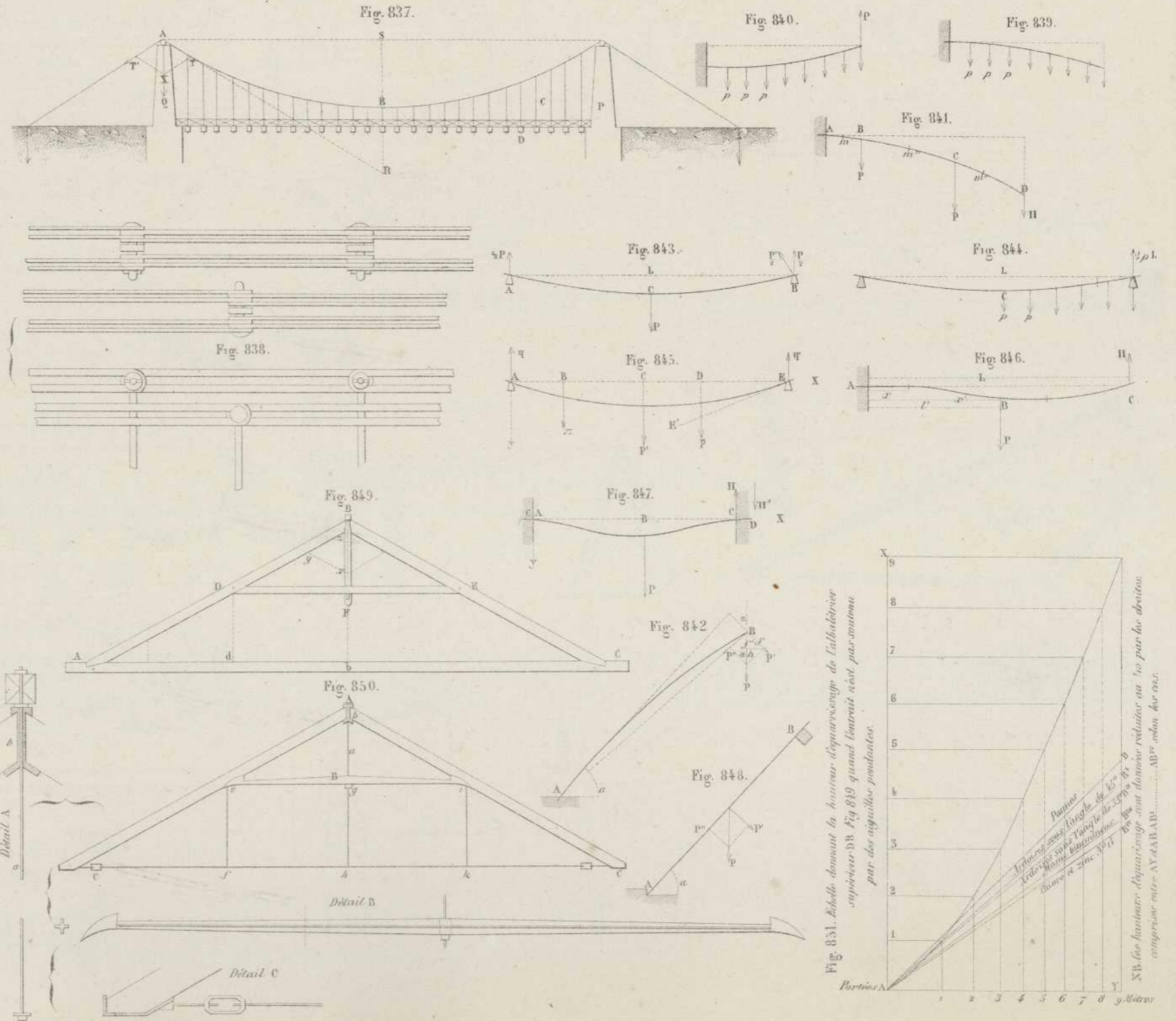
RÉSISTANCE DES MATÉRIAUX.



Matériaux soumis à l'Extension, pièces de section carrée.



Echelle donnant l'équarrissage des pièces comprimées et des pièces tirées dans le sens de leur longueur pour les matériaux de construction les plus employés



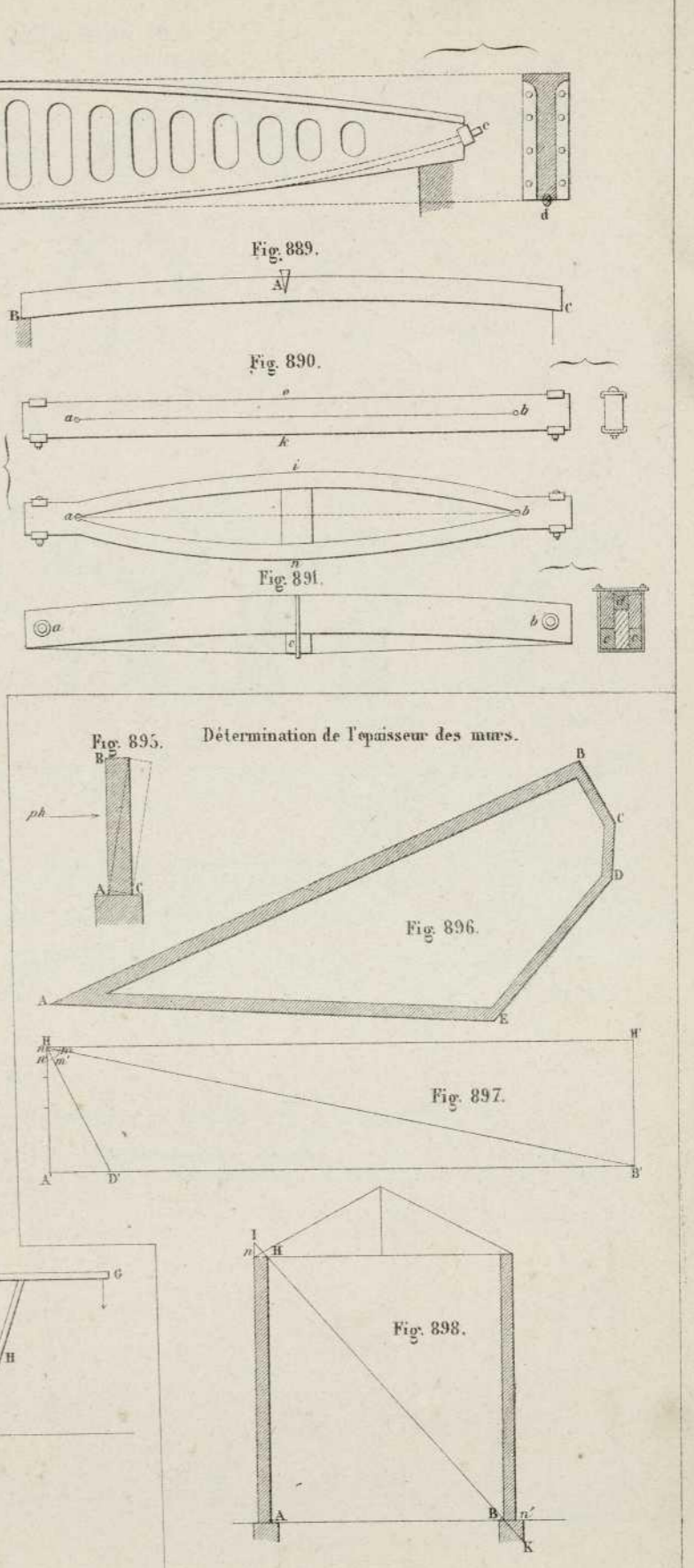
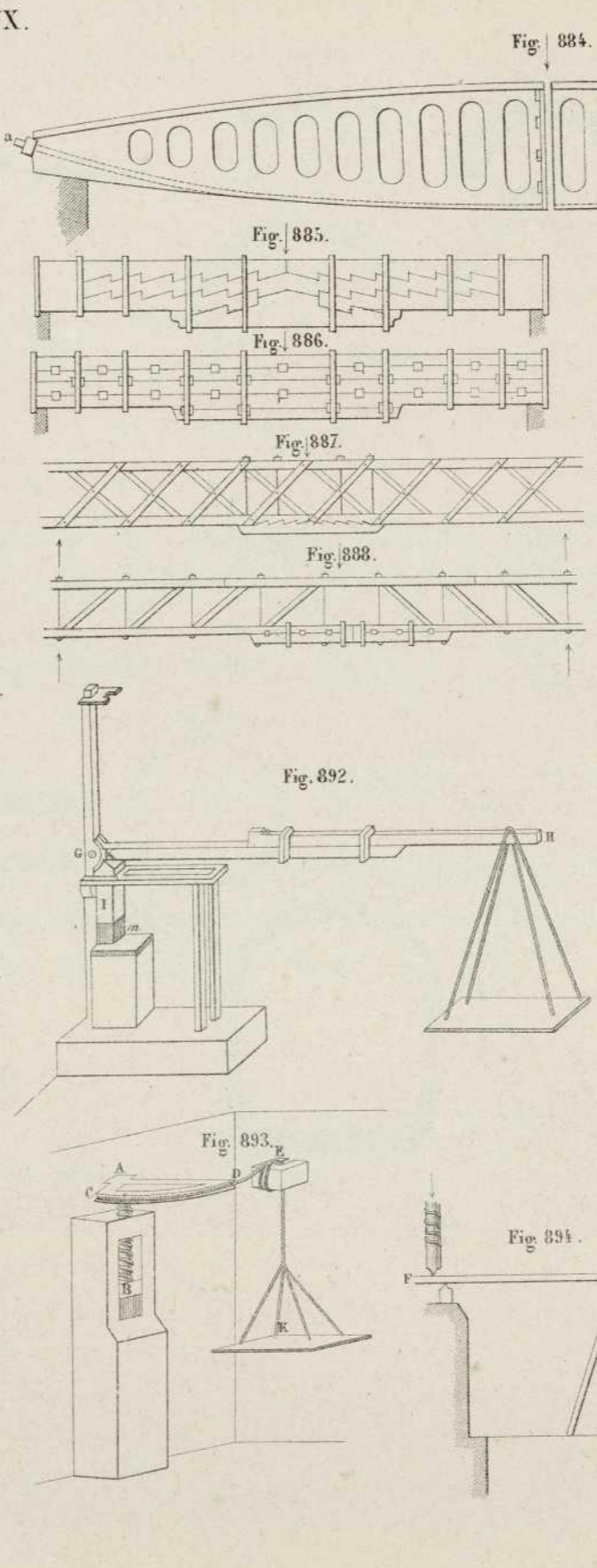
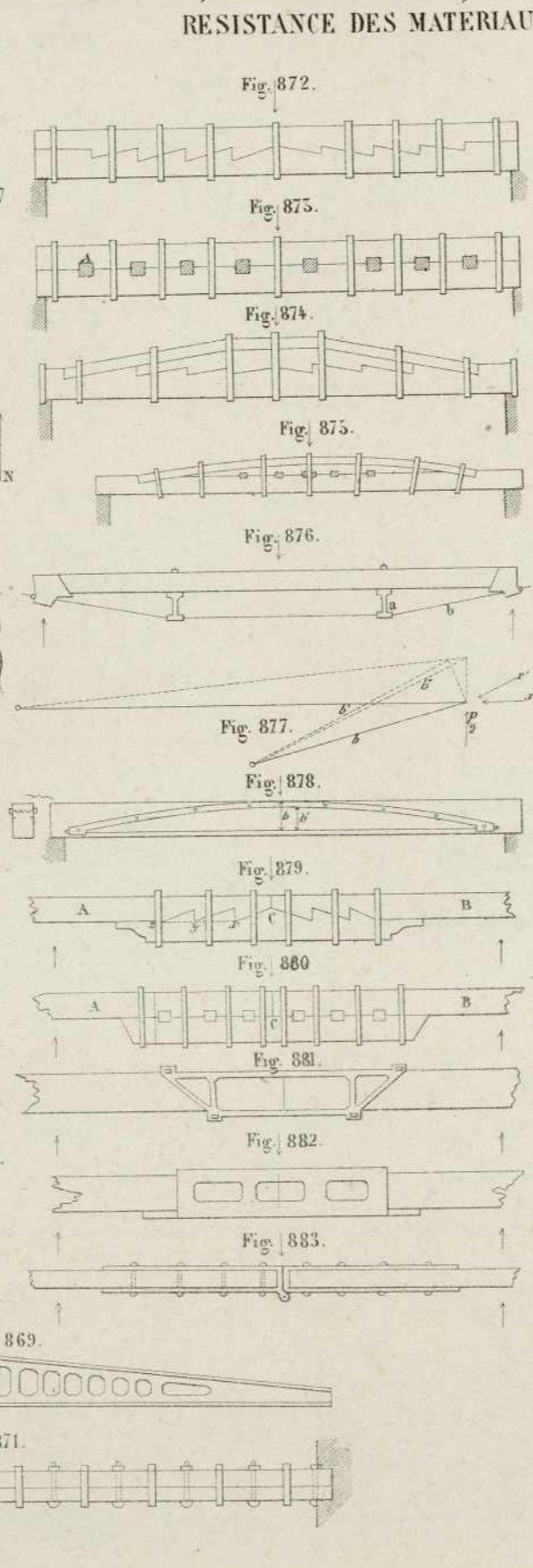
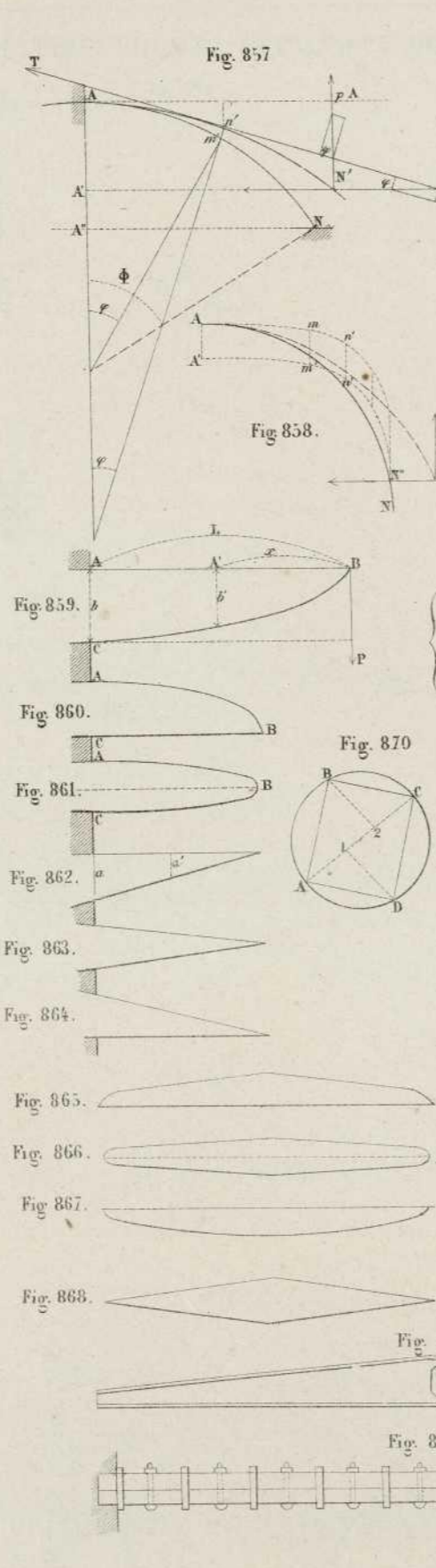
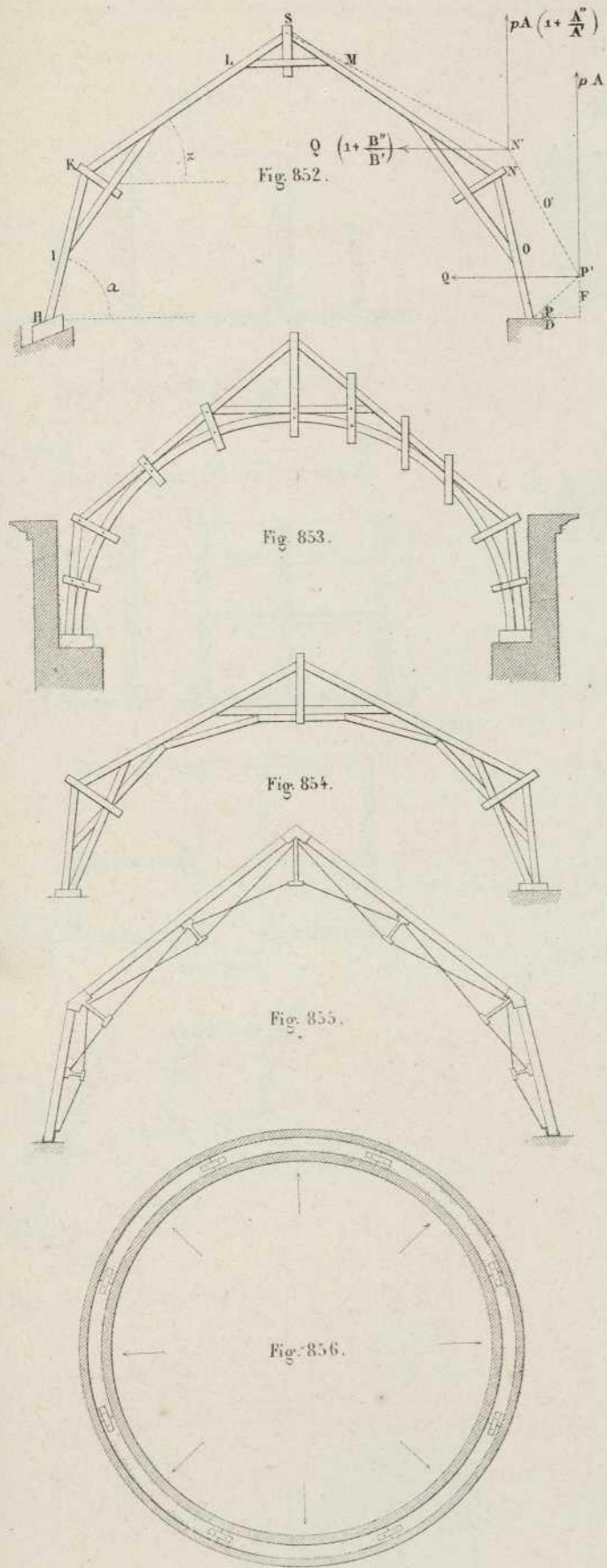
Gravé par M. J. B. Bonaparte 12.







RESISTANCE DES MATÉRIAUX.



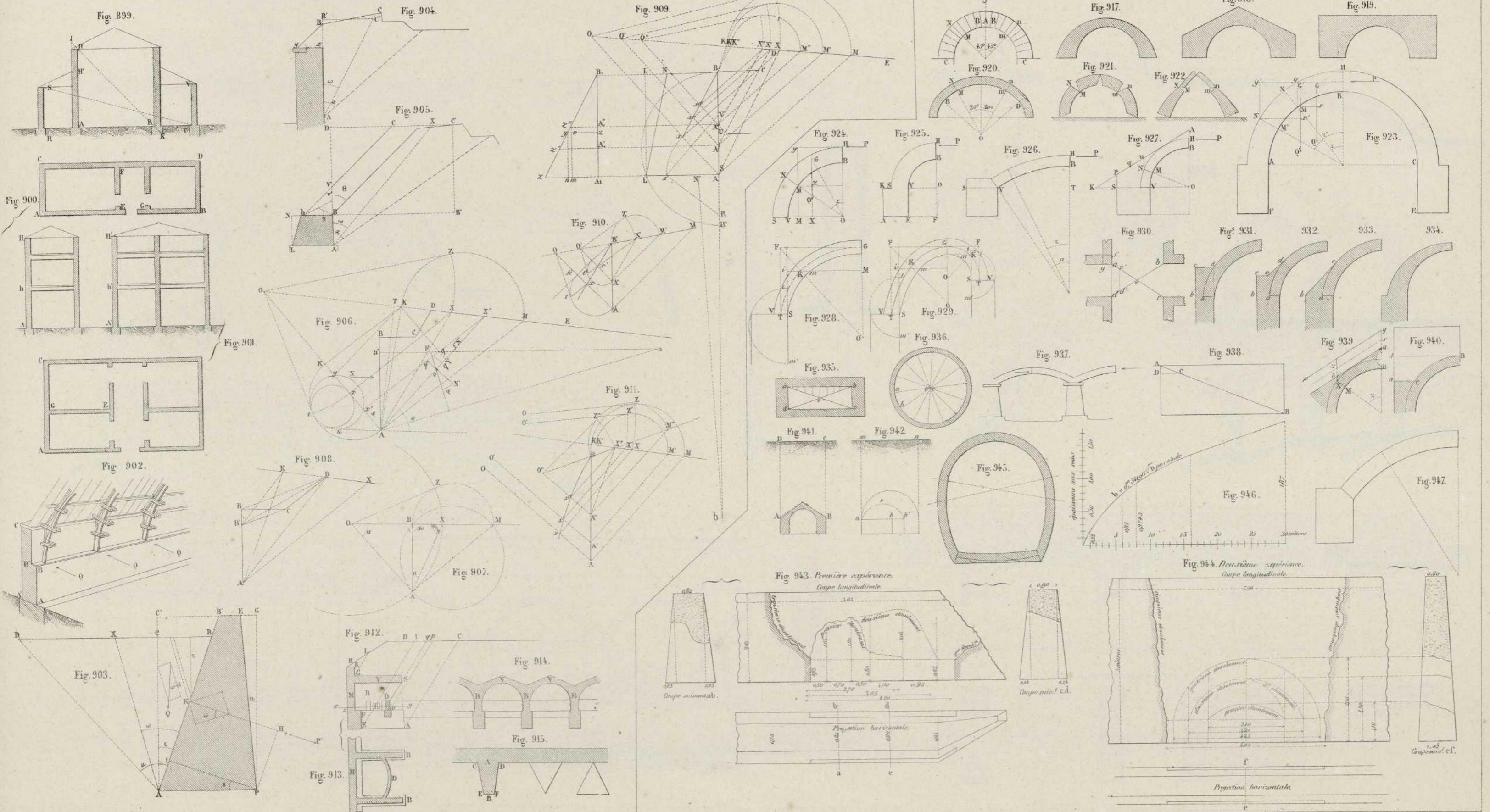




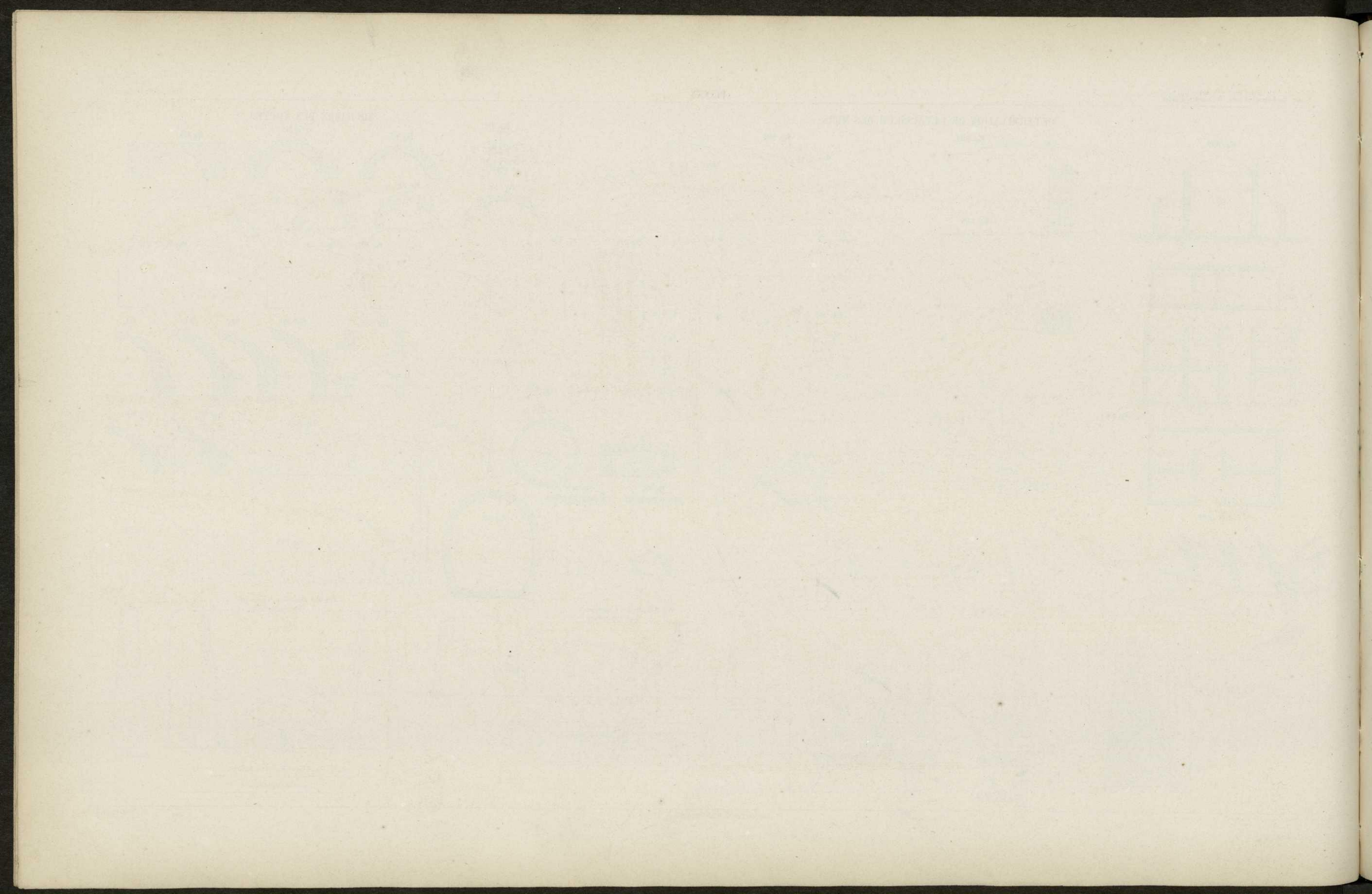


DÉTERMINATION DE L'ÉPAISSEUR DES MURS.

EQUILIBRE DES VOUTES.









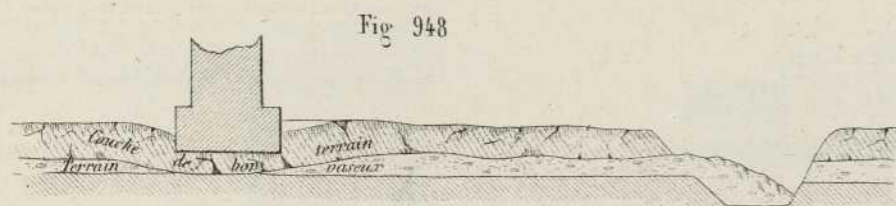


Fig. 948

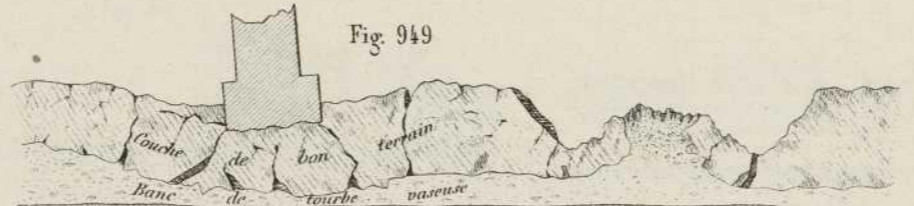


Fig. 949

dans les Fig. 948 et 949 les lignes pointillées indiquent le profil du terrain avant l'affaissement

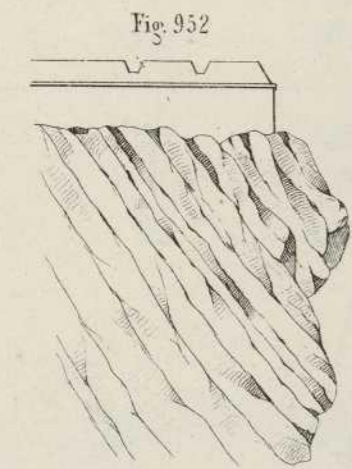


Fig. 952

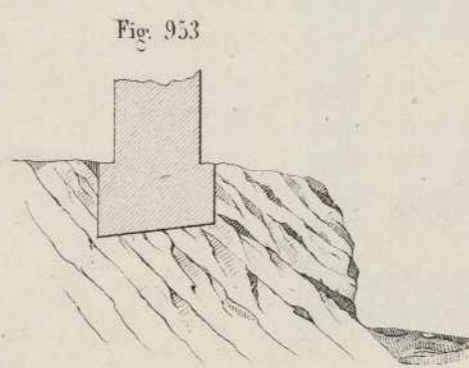


Fig. 953

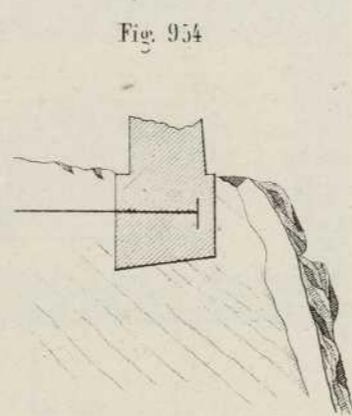


Fig. 954

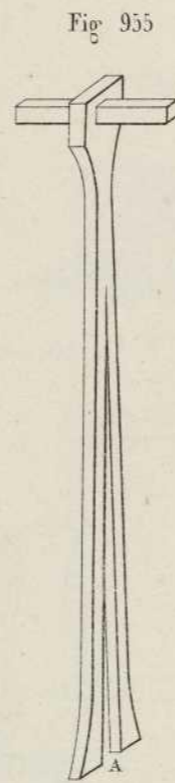


Fig. 955

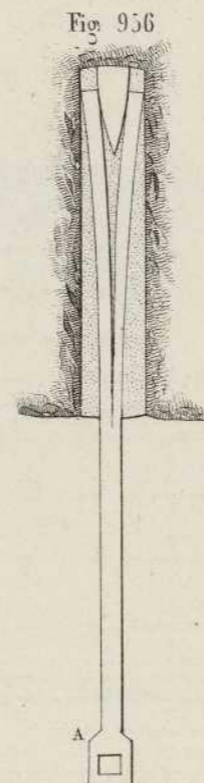


Fig. 956

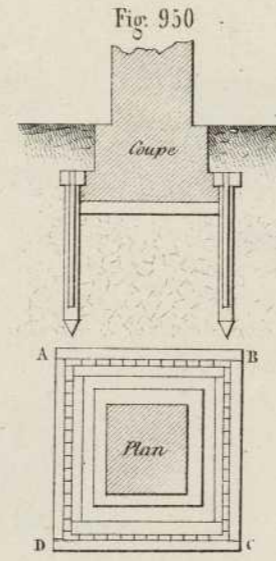


Fig. 950

ABCD Encastrement en charpente

Fig. 957

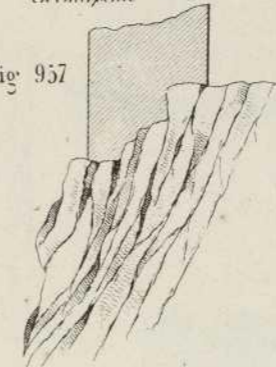


Fig. 951

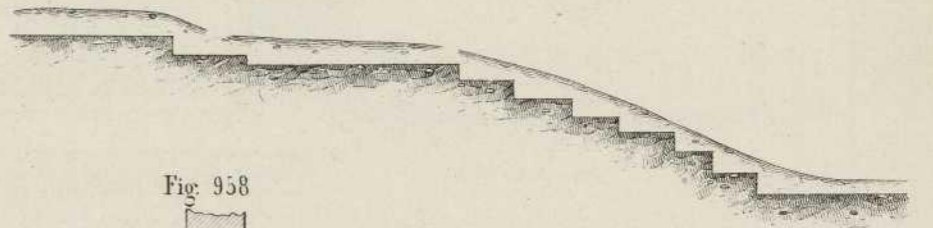


Fig. 958

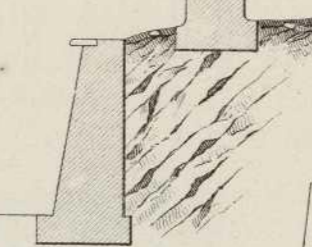
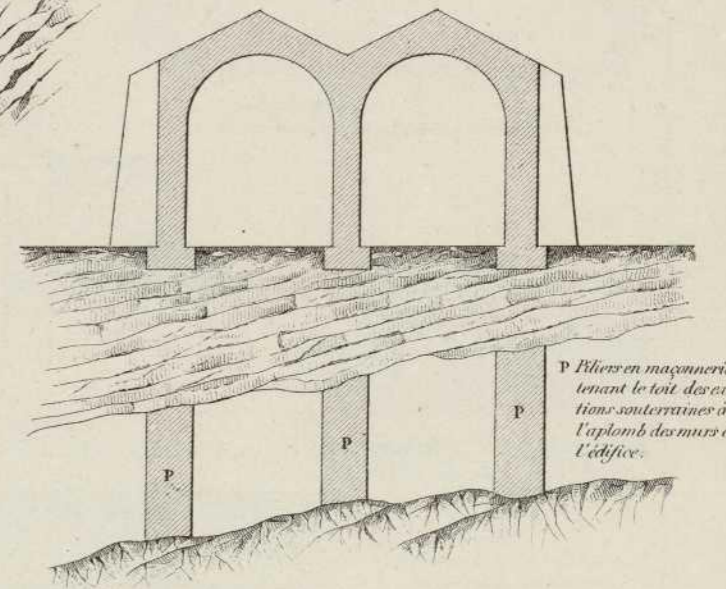


Fig. 959



P Piliers en maçonnerie soutenant le toit des excavations souterraines à l'appui des murs de l'édifice.

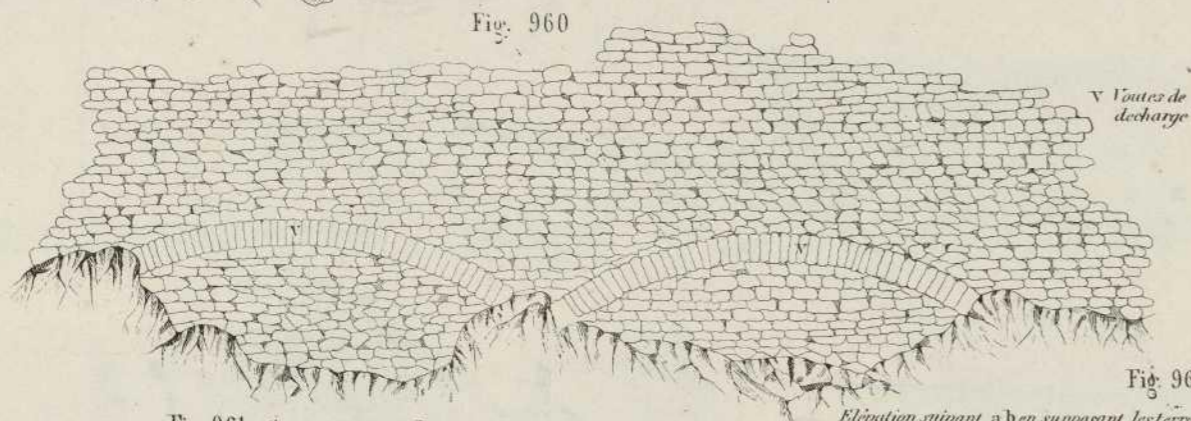


Fig. 960

Voutes de décharge

Fig. 962

Elevation suivant a b en supplant les terres enlevées jusques contre les maçonneries

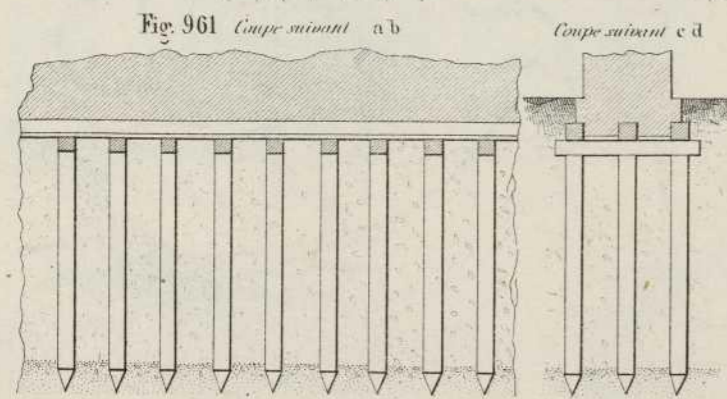
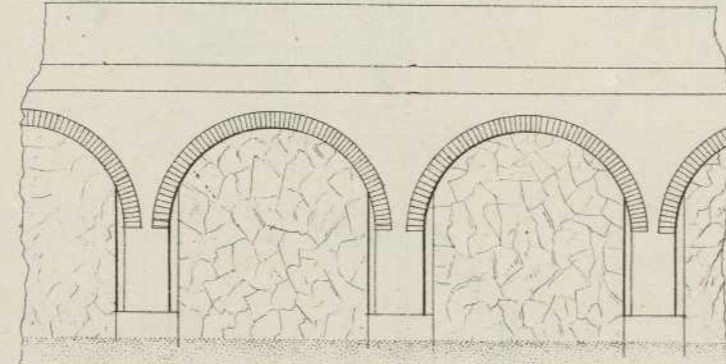
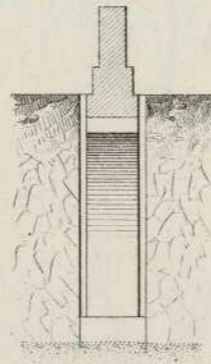


Fig. 961 Coupe suivant a b

Coupe suivant c d



Plan



Coupe suivant c d en supplant les terres enlevées sous l'arcade de décharge.

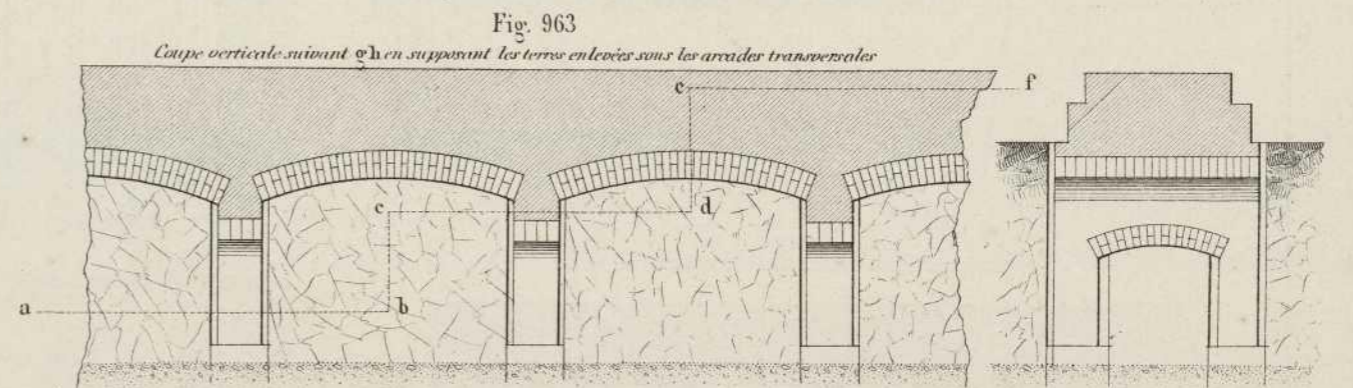
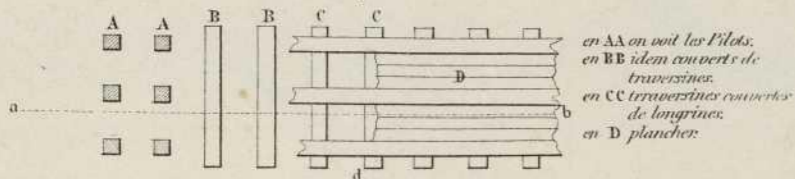


Fig. 963

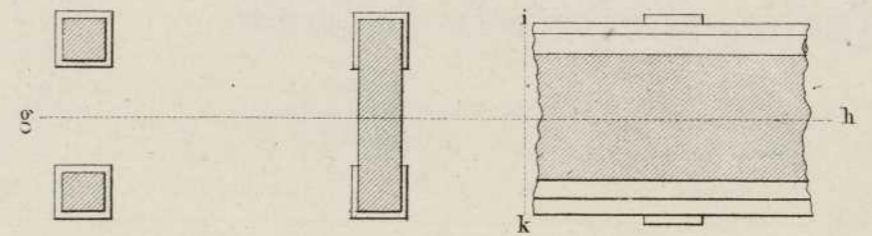
Coupe verticale suivant g h en supplant les terres enlevées sous les arcades transversales

Coupe horizontale suivant a b e d e f

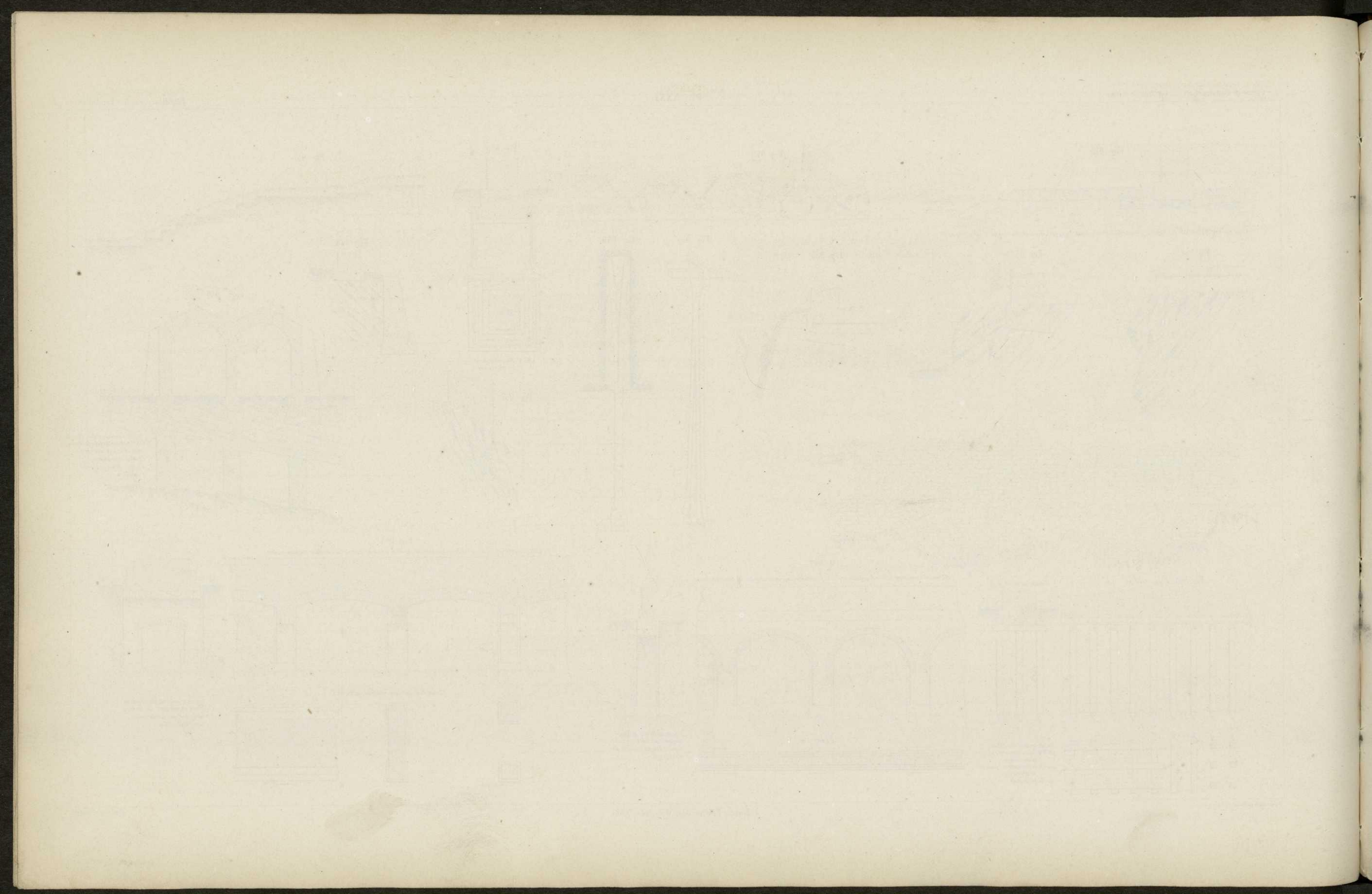
Coupe transversale suivant i k en supplant les terres enlevées sous les arcades longitudinales.



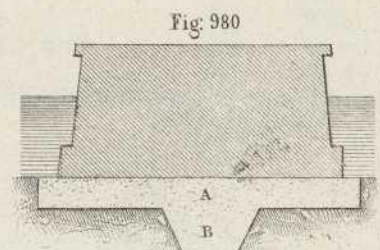
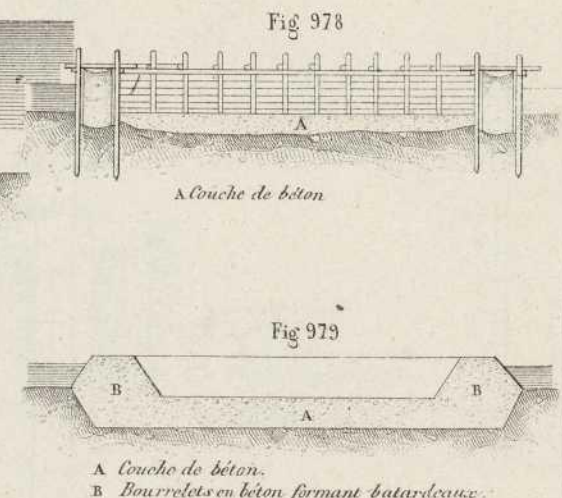
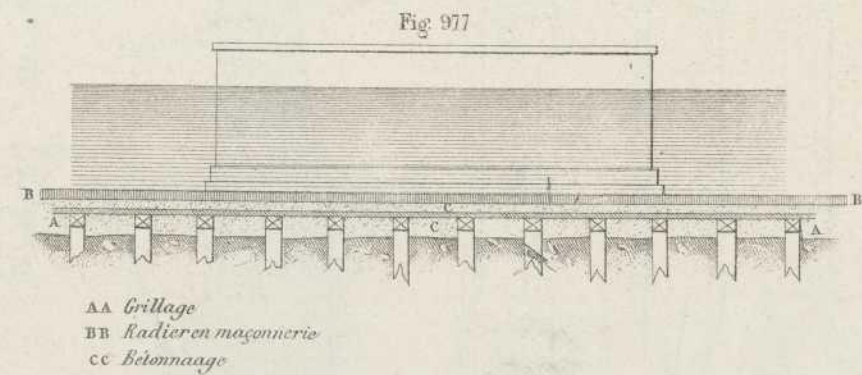
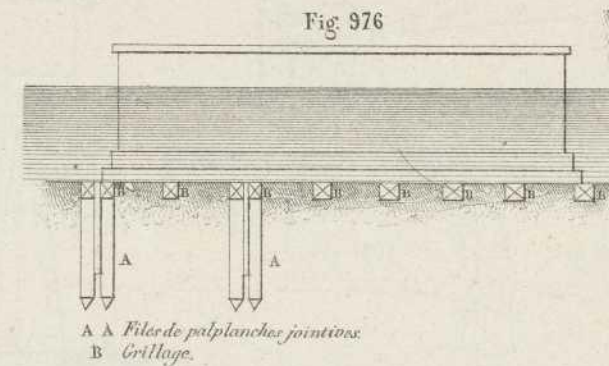
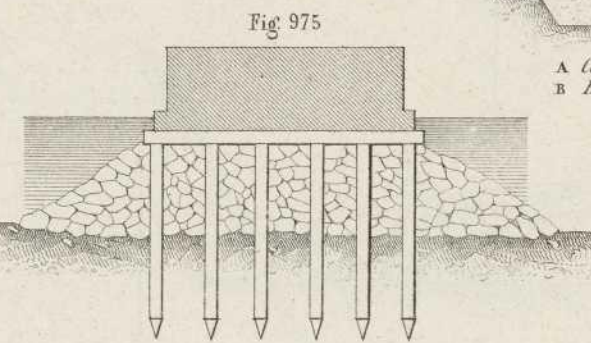
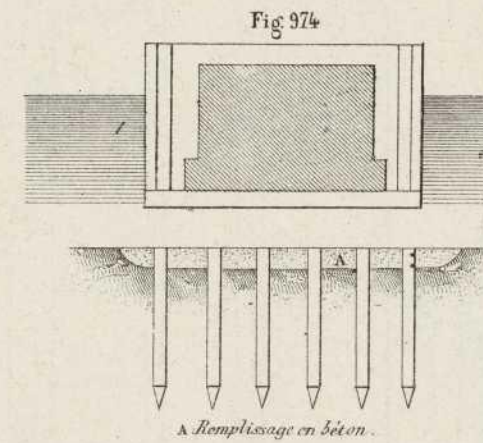
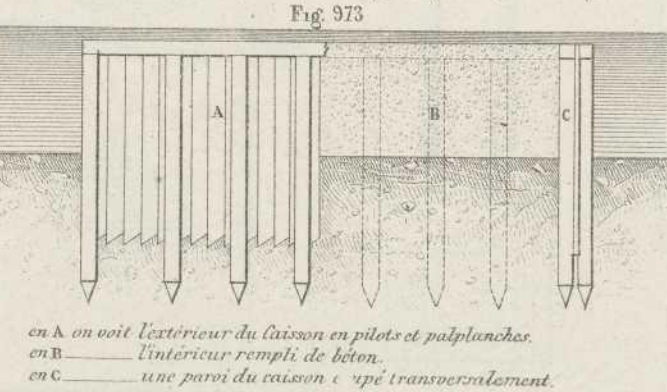
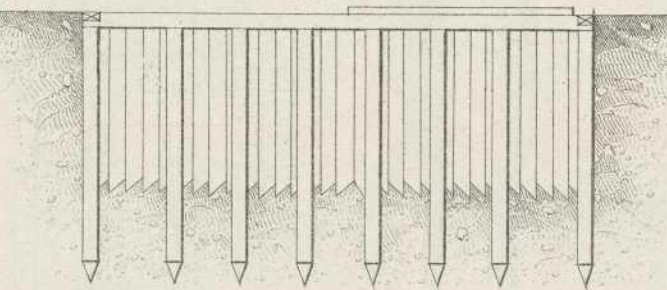
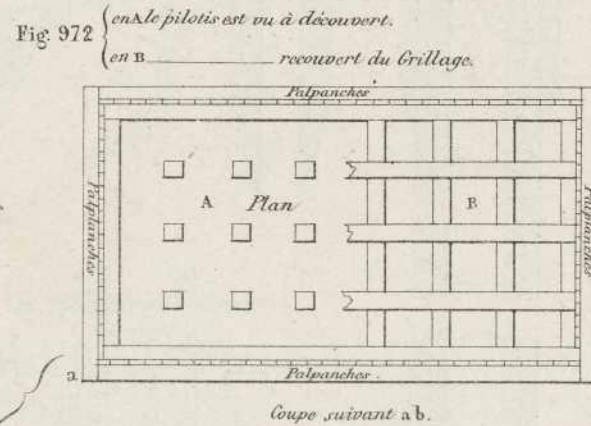
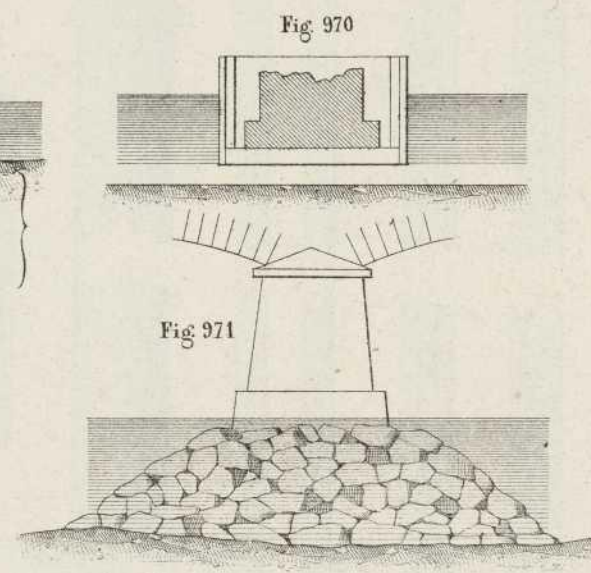
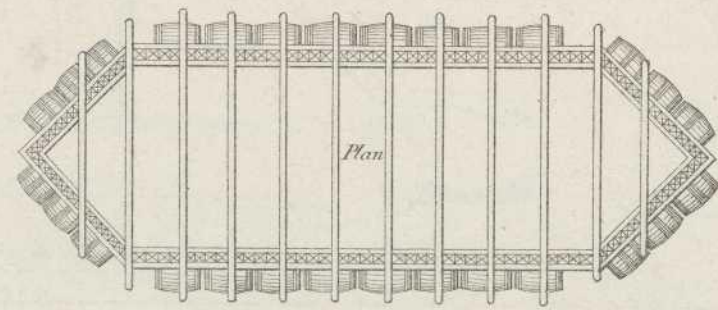
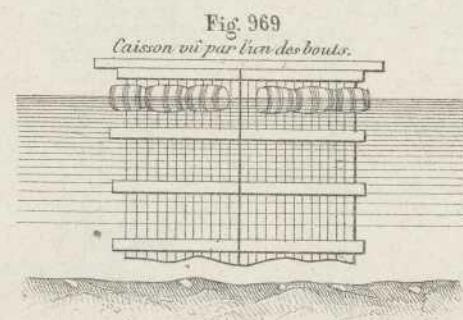
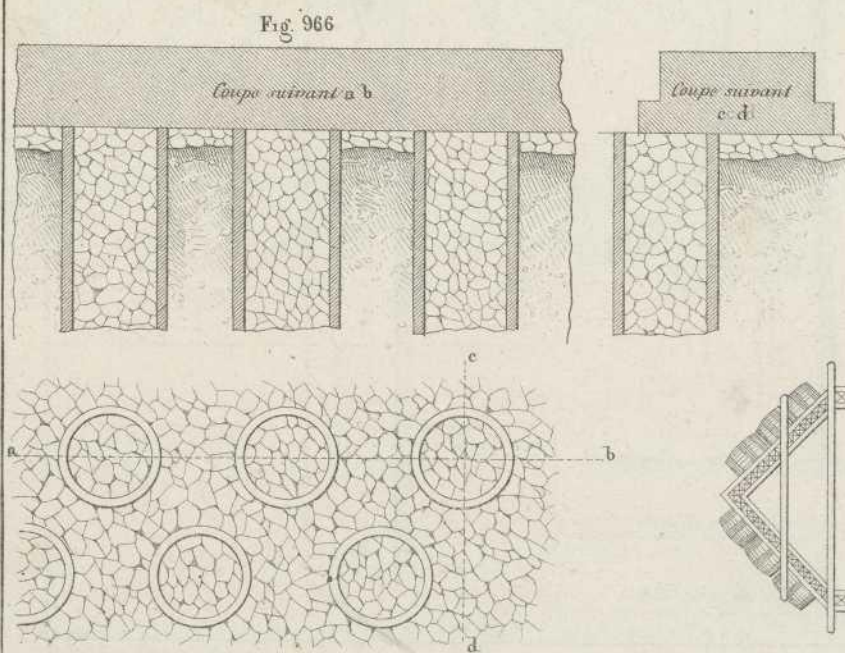
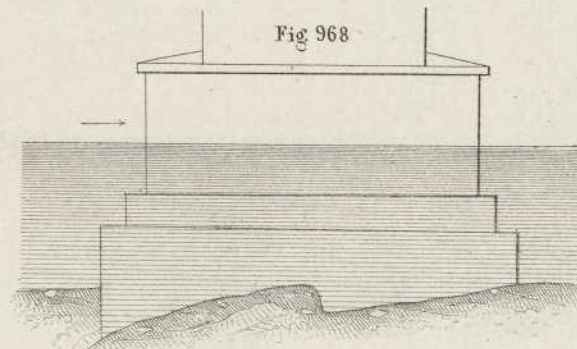
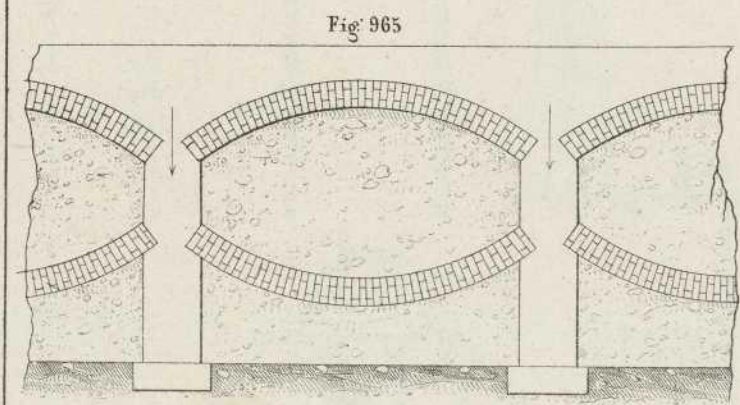
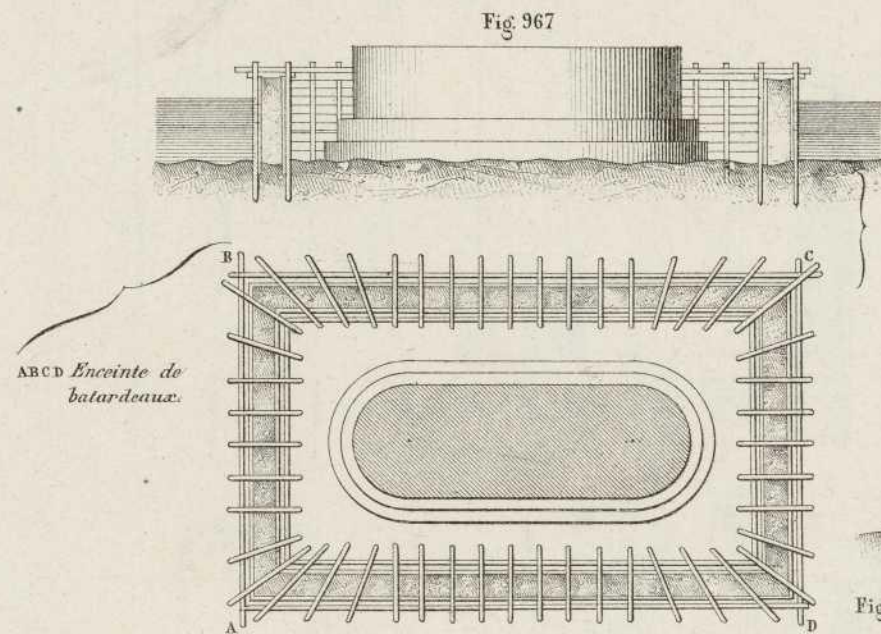
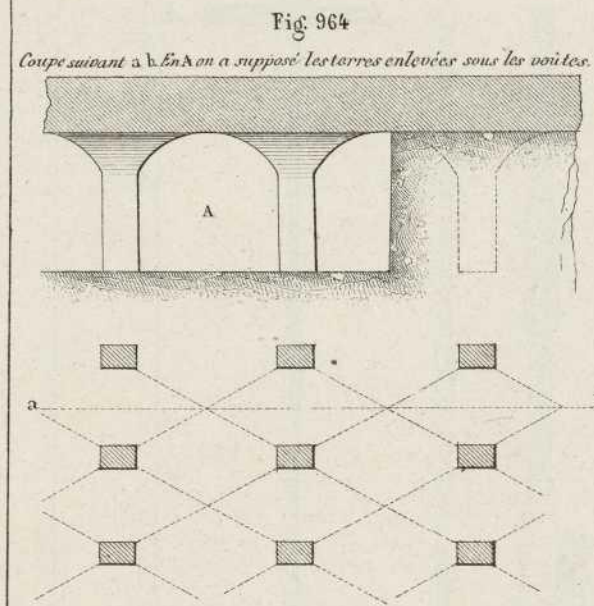
en AA on voit les Piliers, en BB idem couverts de traversines, en CC traversines couvertes de longrines, en D planches.







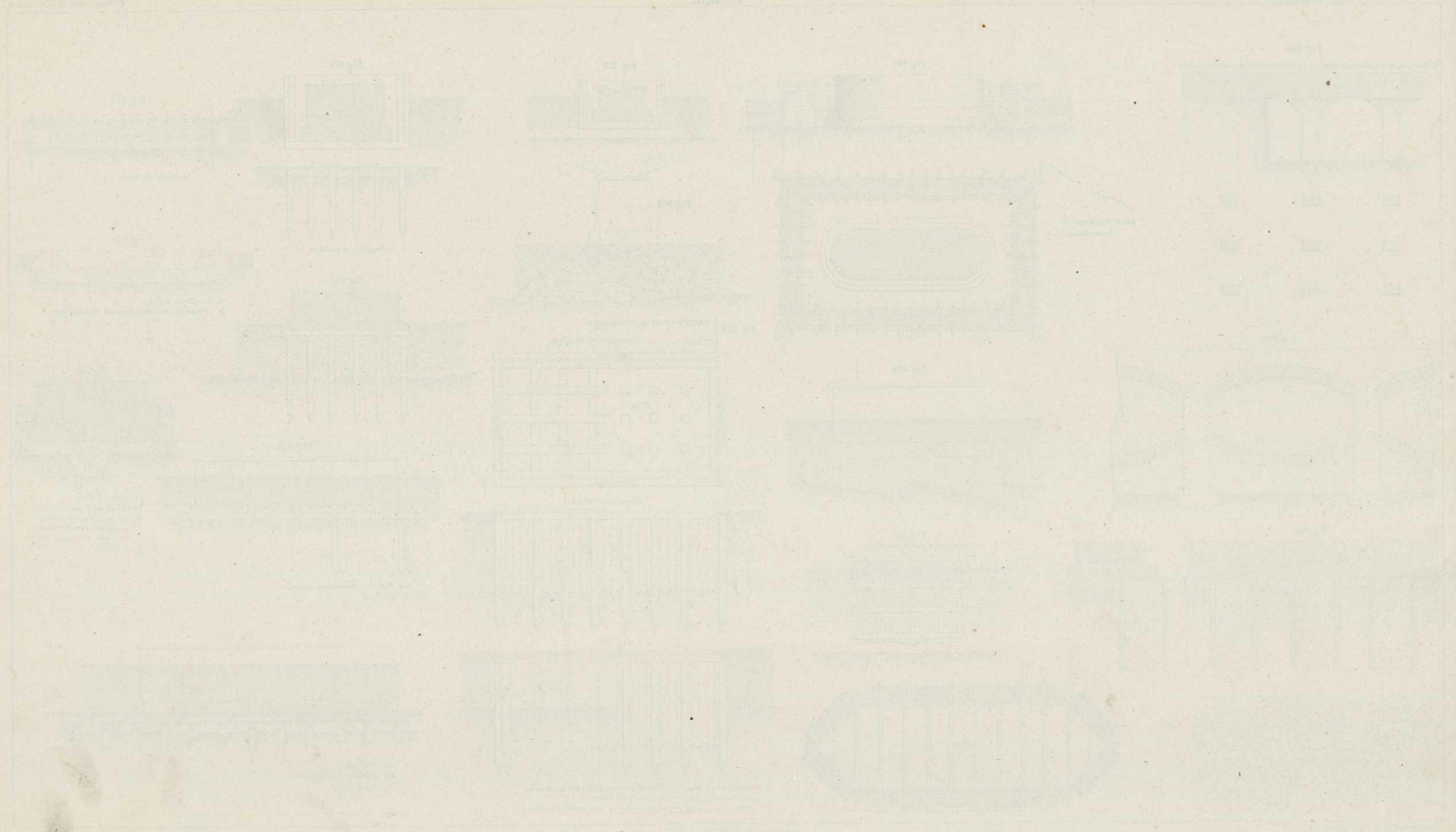




A Couche de béton.

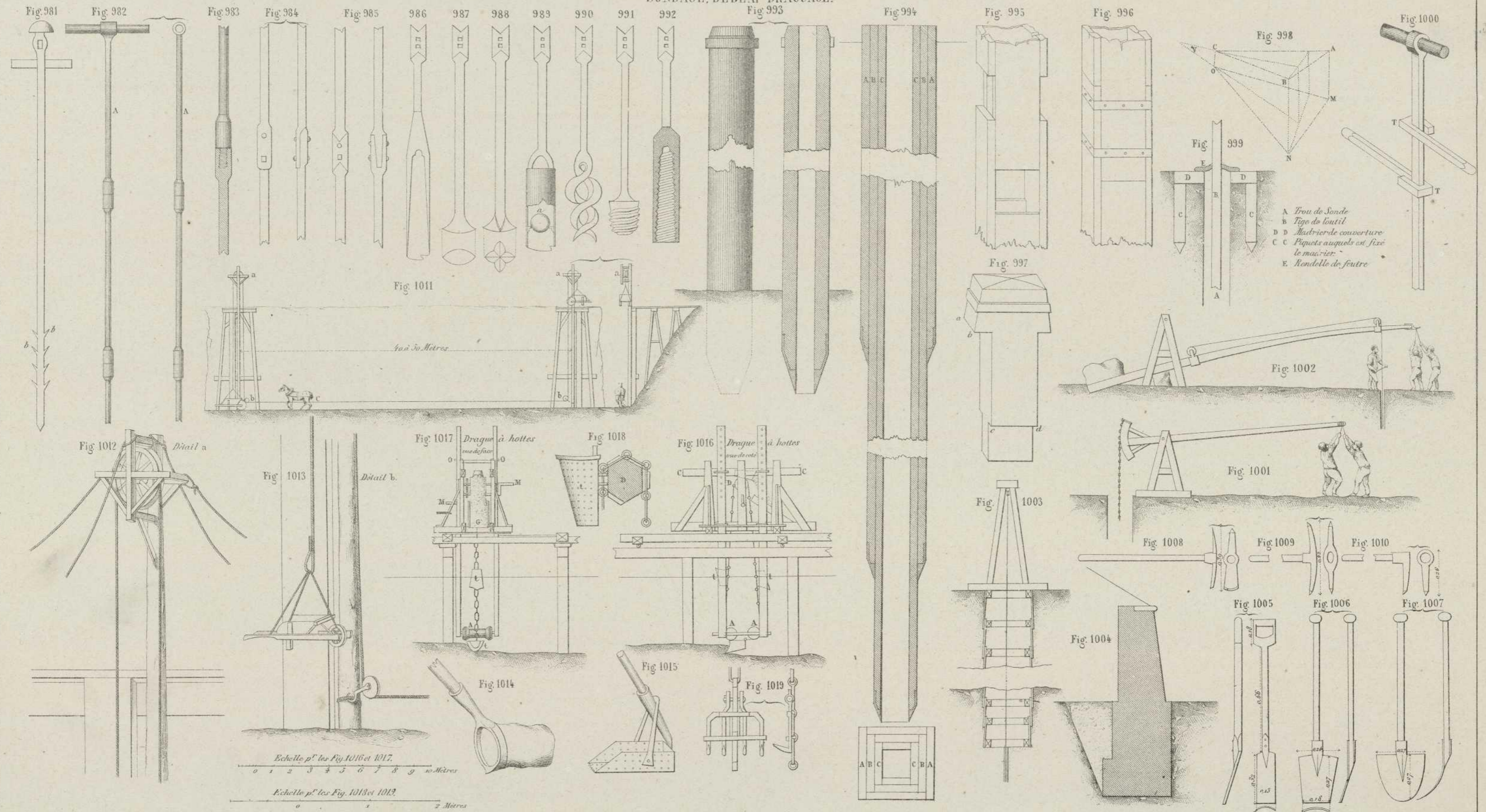
B Crevin en béton ou en glaise qui peut être encastré ou simplement coulé dans une tranchée non revêtue de charpente.



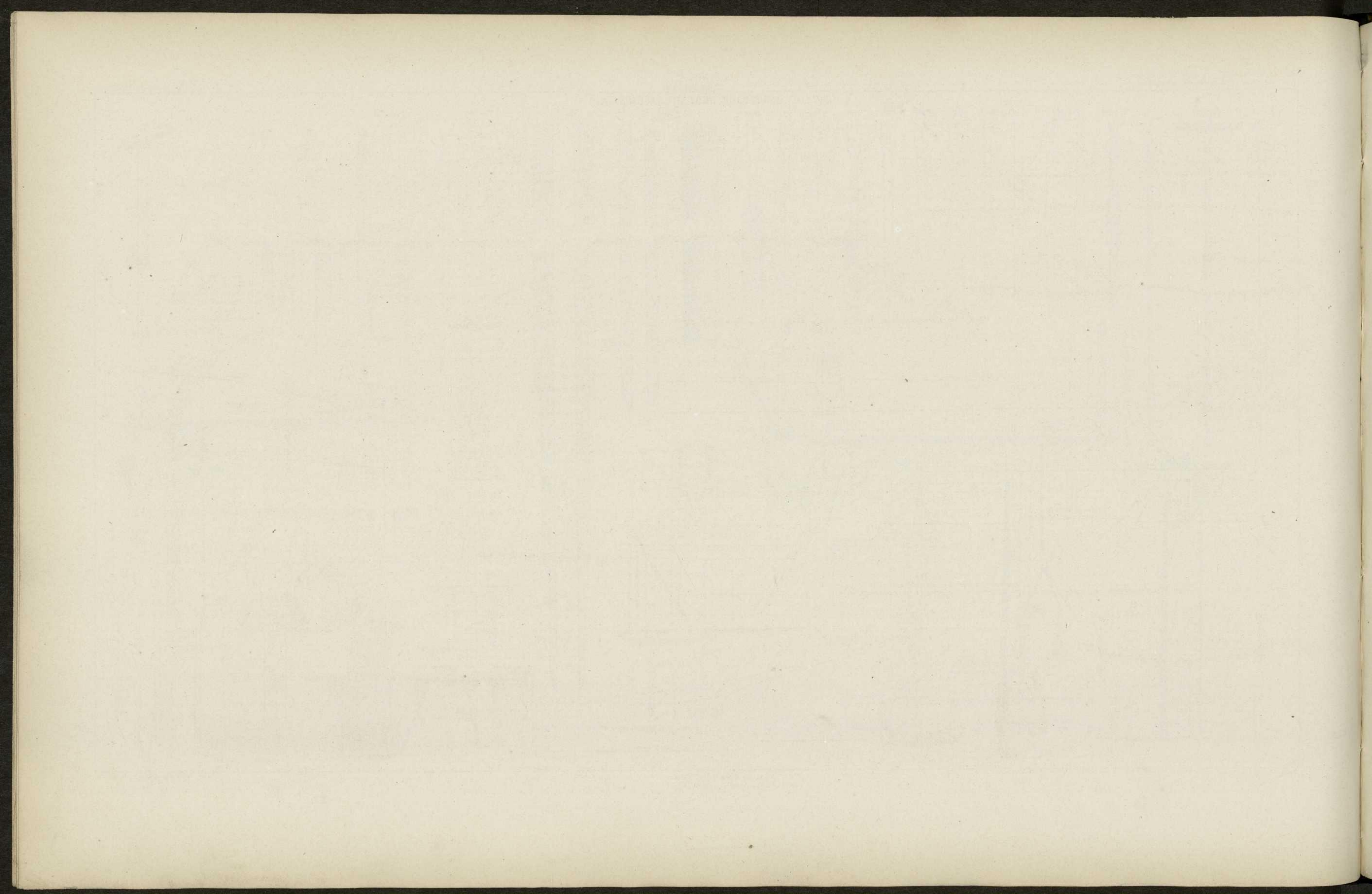




SONDAGE, DEBLAI DRAGAGE.

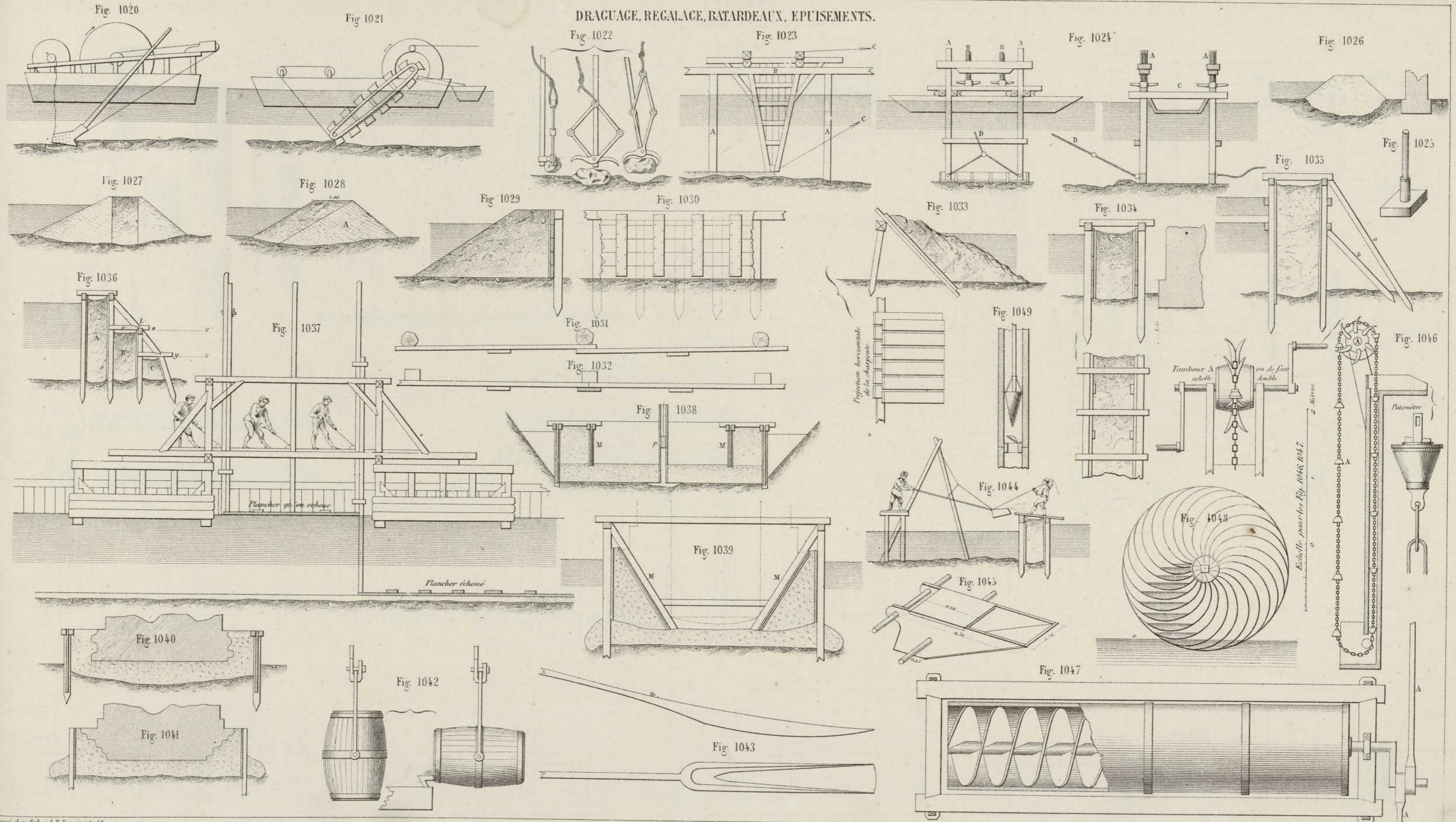






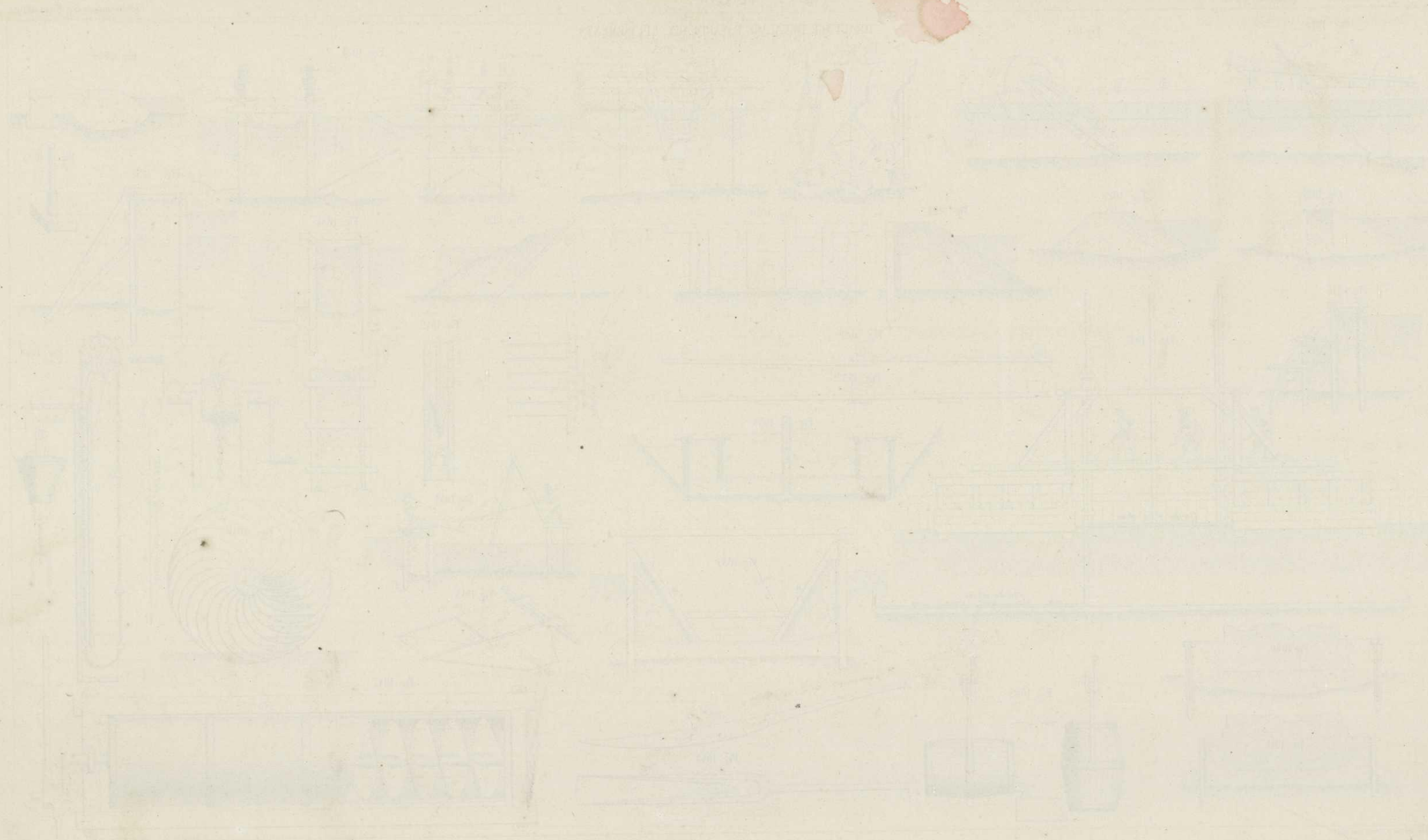


DRAGAGE, REGALAGE, BATARDEAUX, EPUISEMENTS.



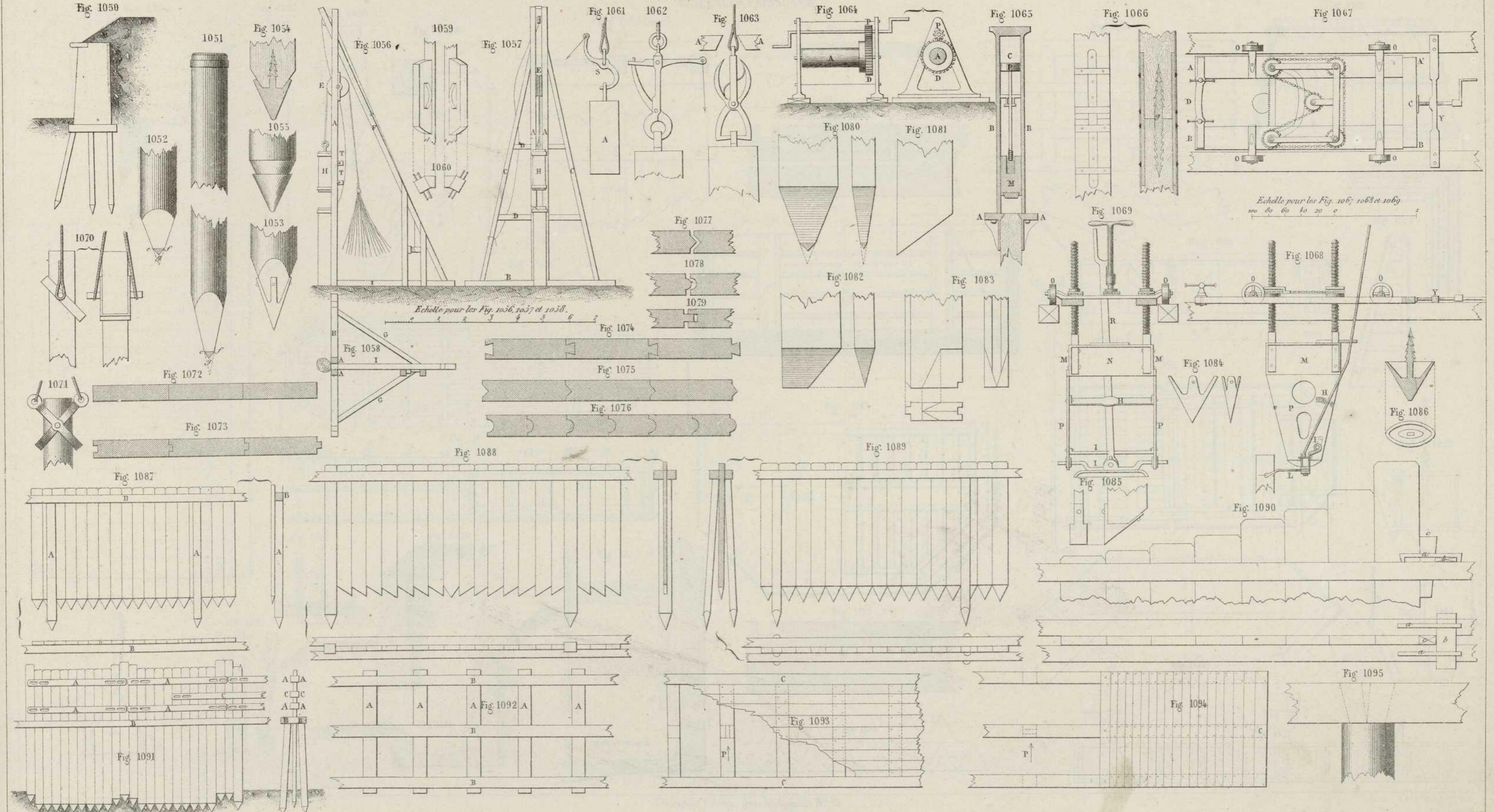
Gravé chez Erhard B. Bonaparte 42.





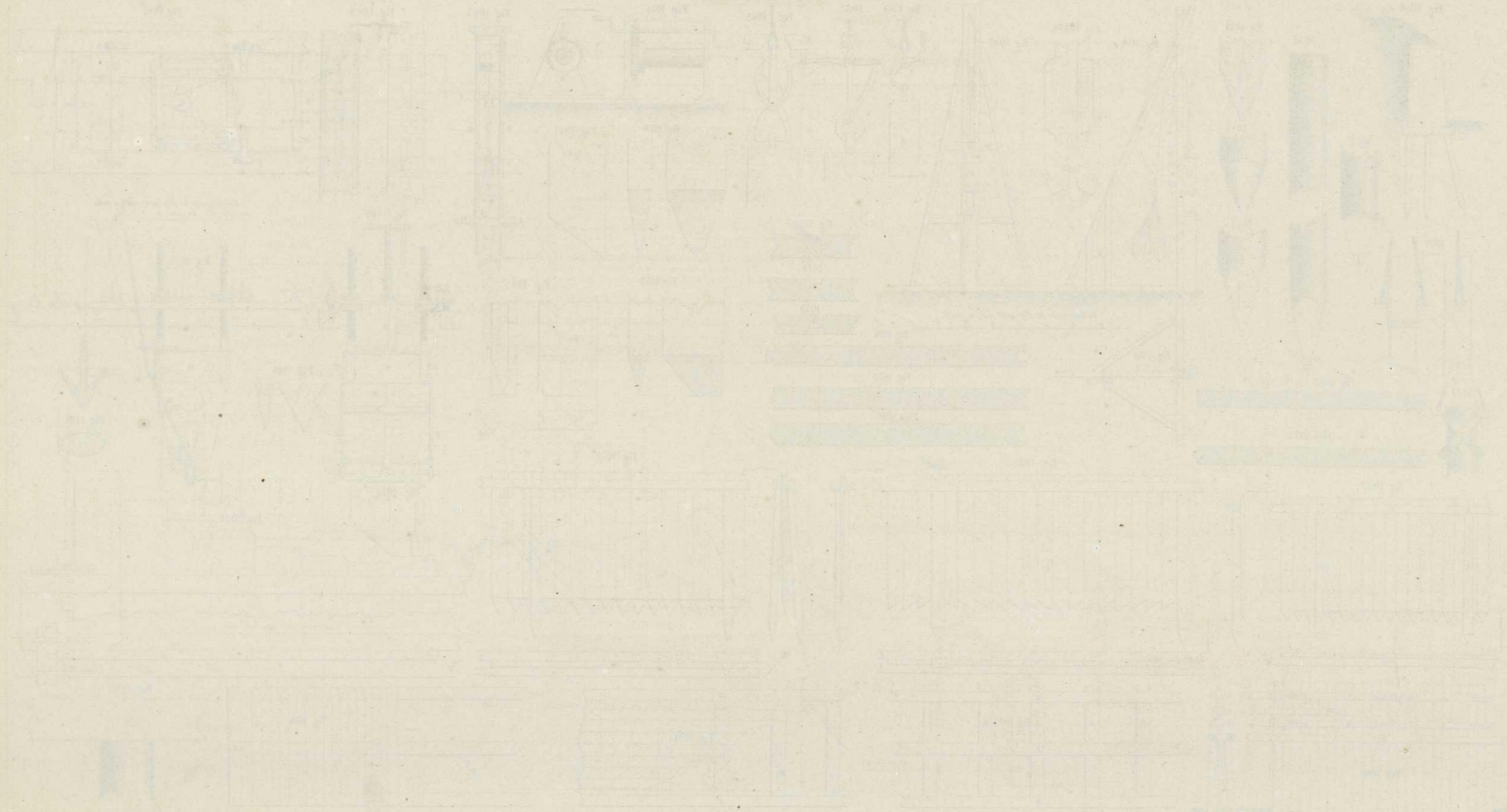


PILOTIS, PALPLANCHES, GRILLAGES.



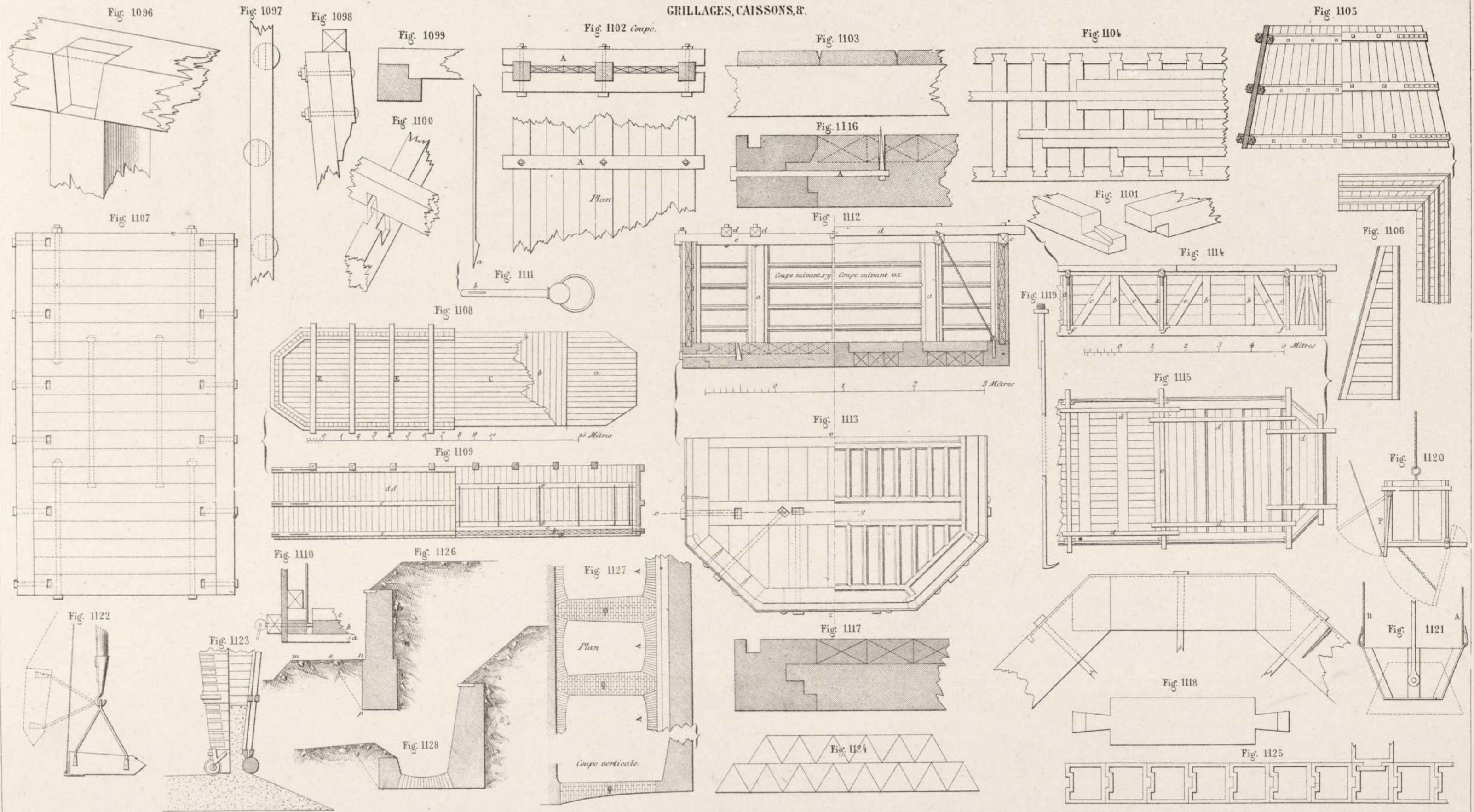


SECTIONAL DRAWINGS OF THE

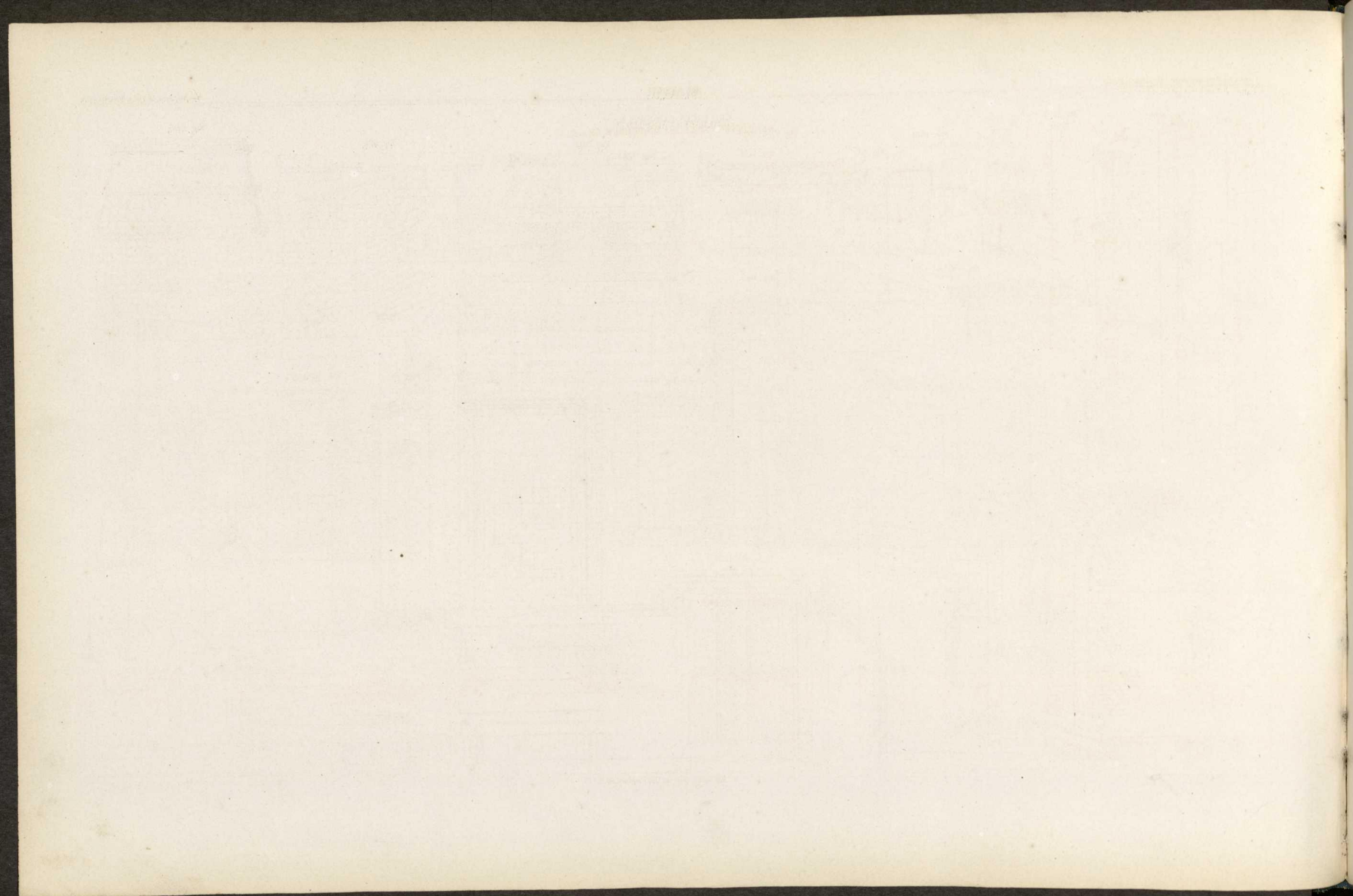




GRILLAGES, CAISSONS, &c.

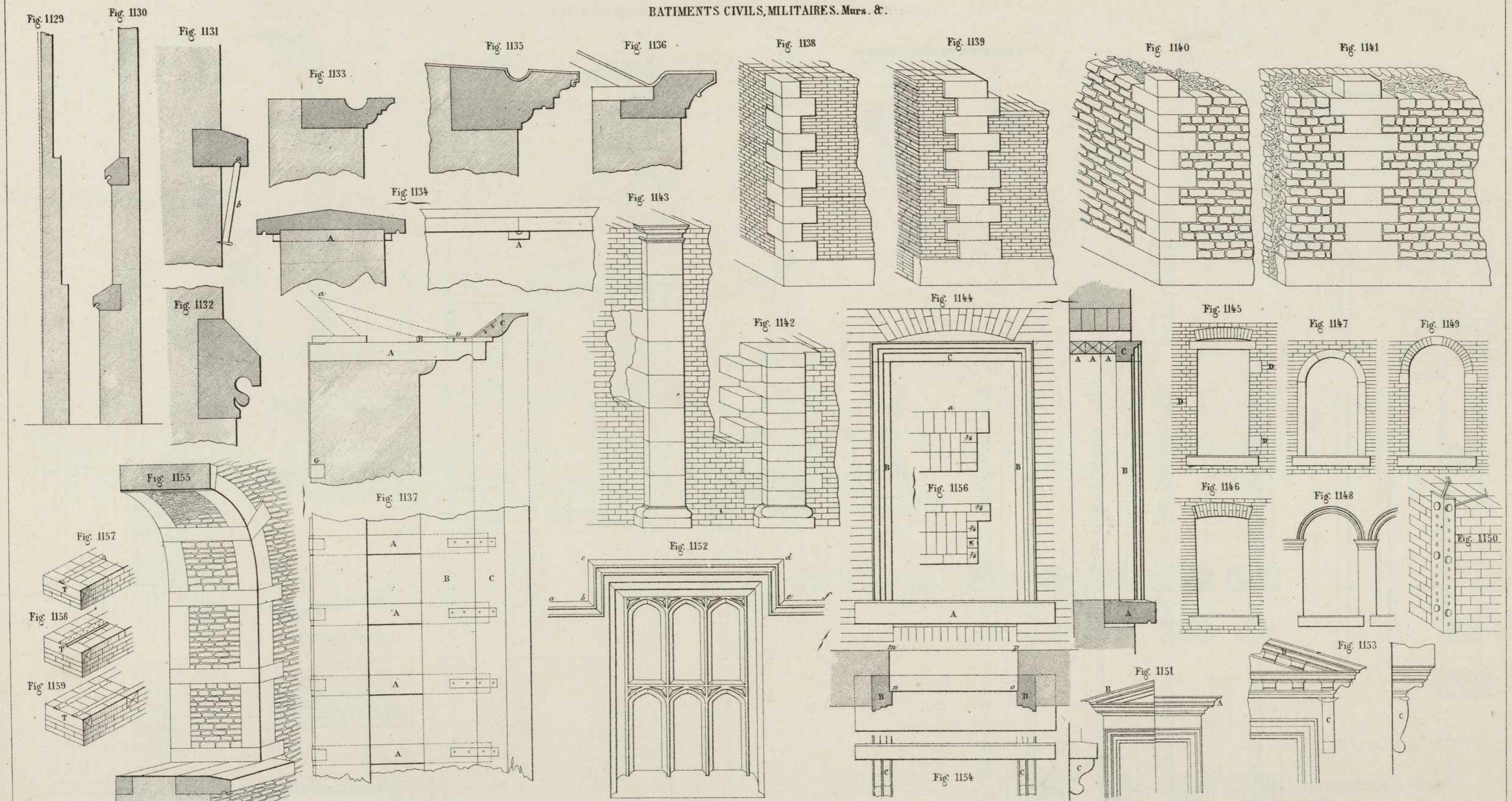




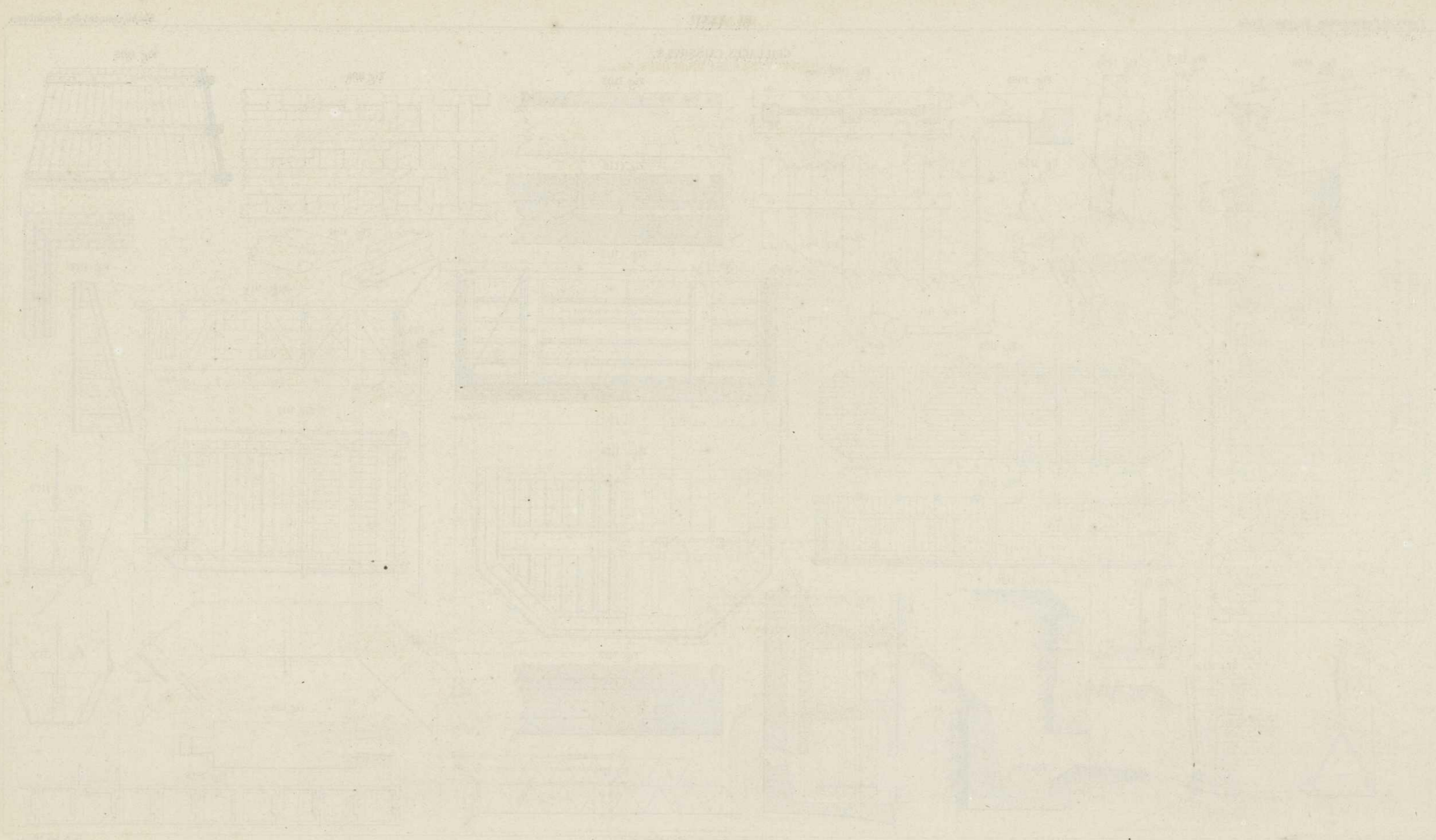




BATIMENTS CIVILS, MILITAIRES. Murs. &c.

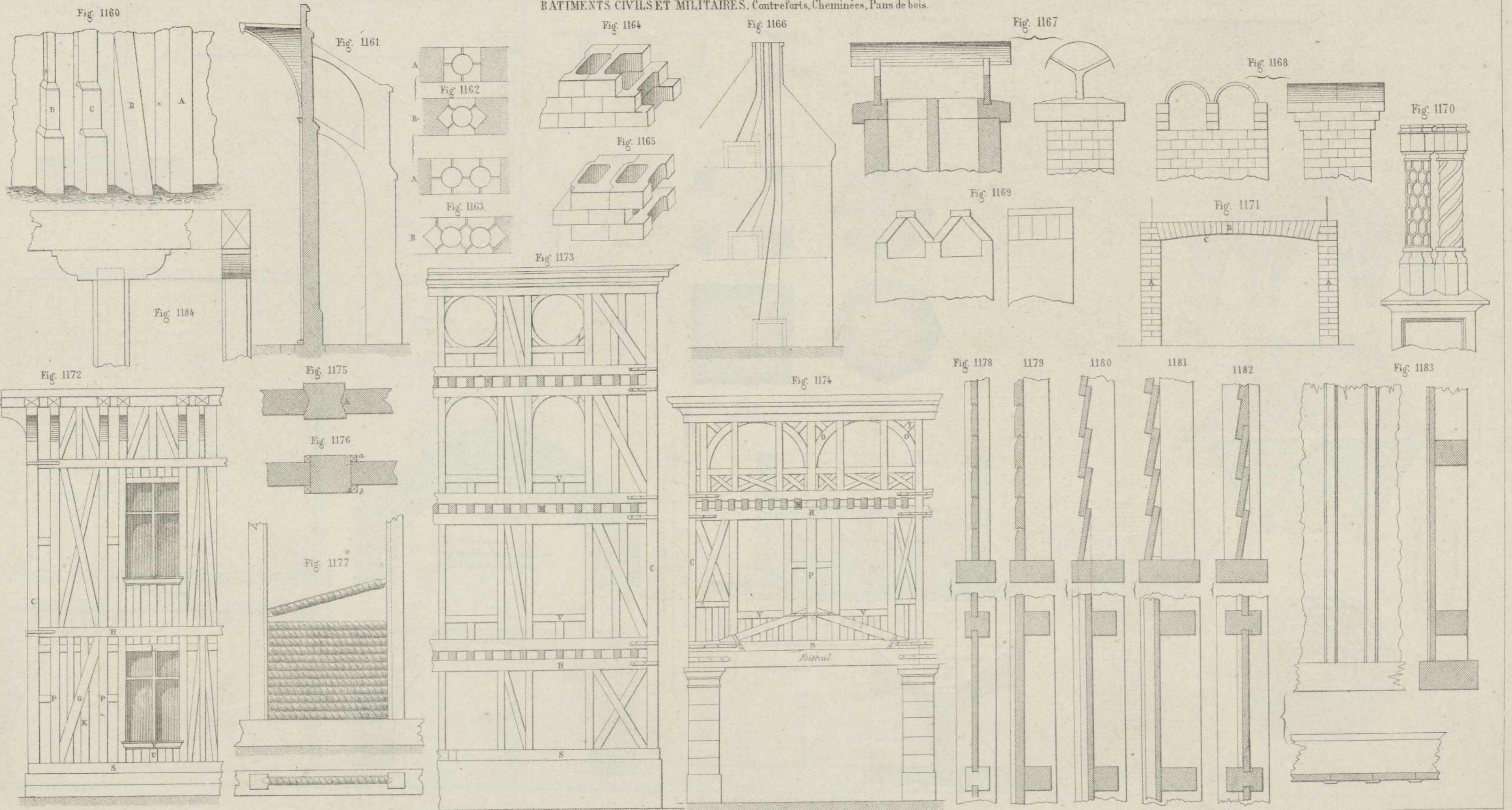




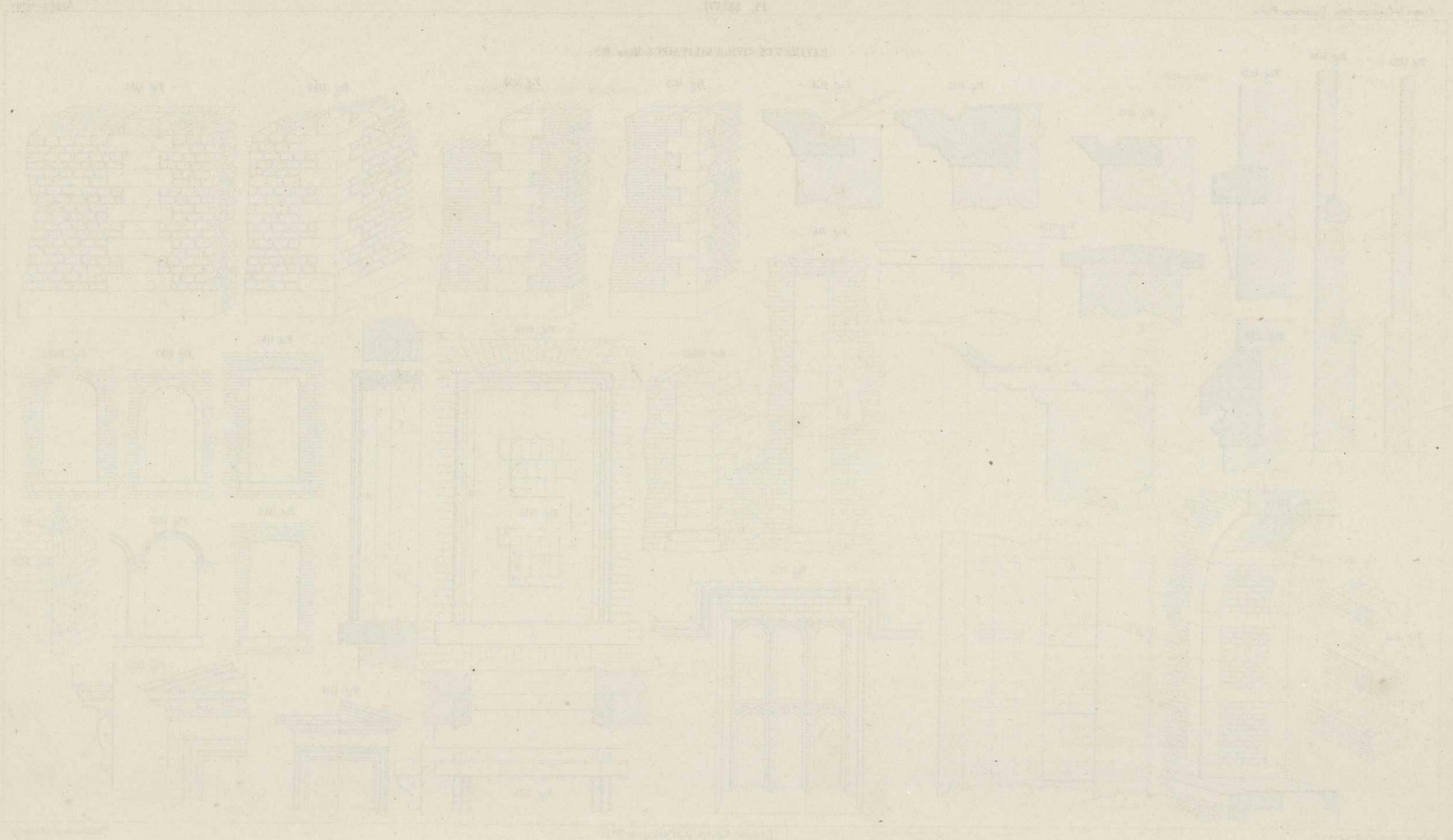




BATIMENTS CIVILS ET MILITAIRES. Contreforts, Cheminées, Pans de bois.

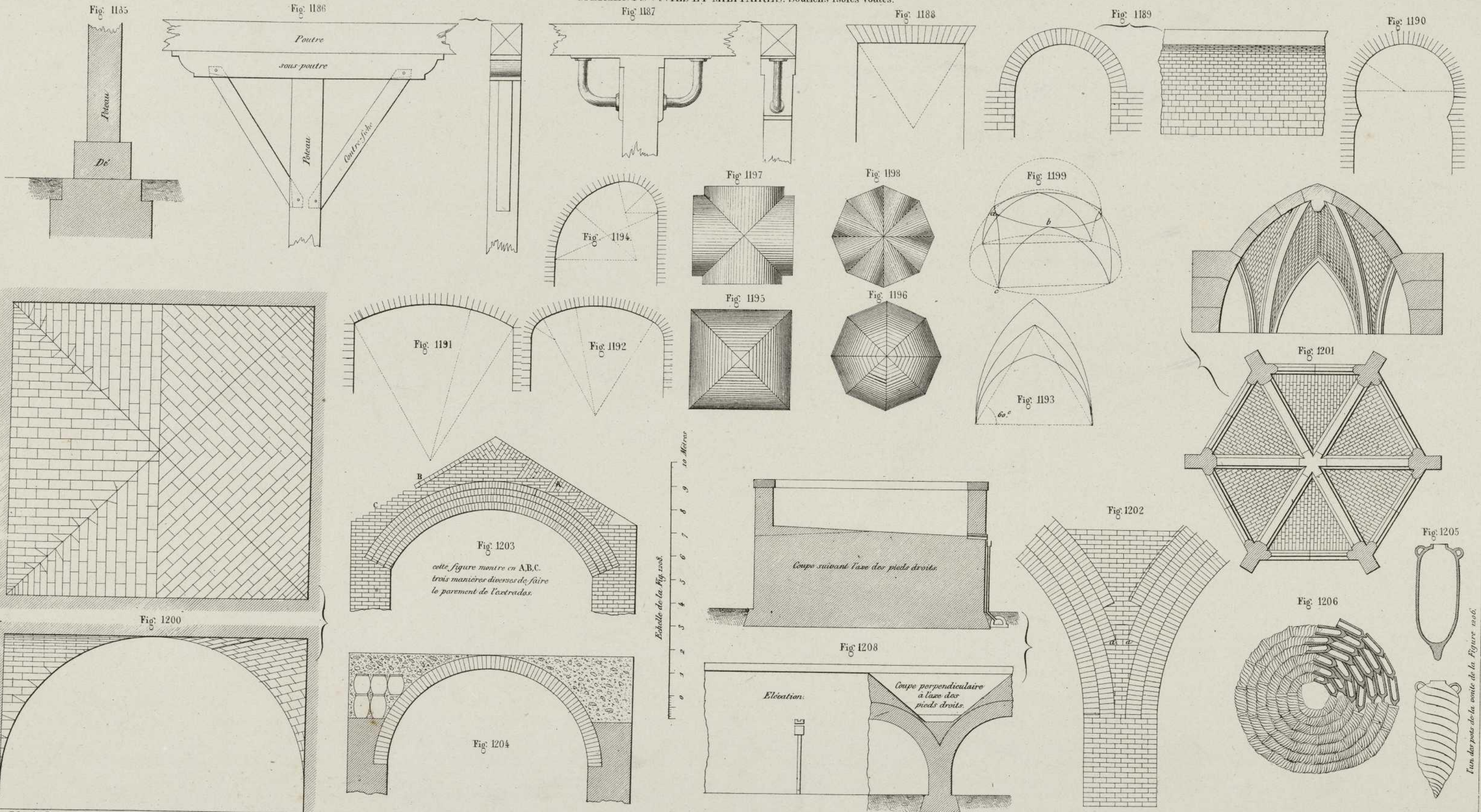






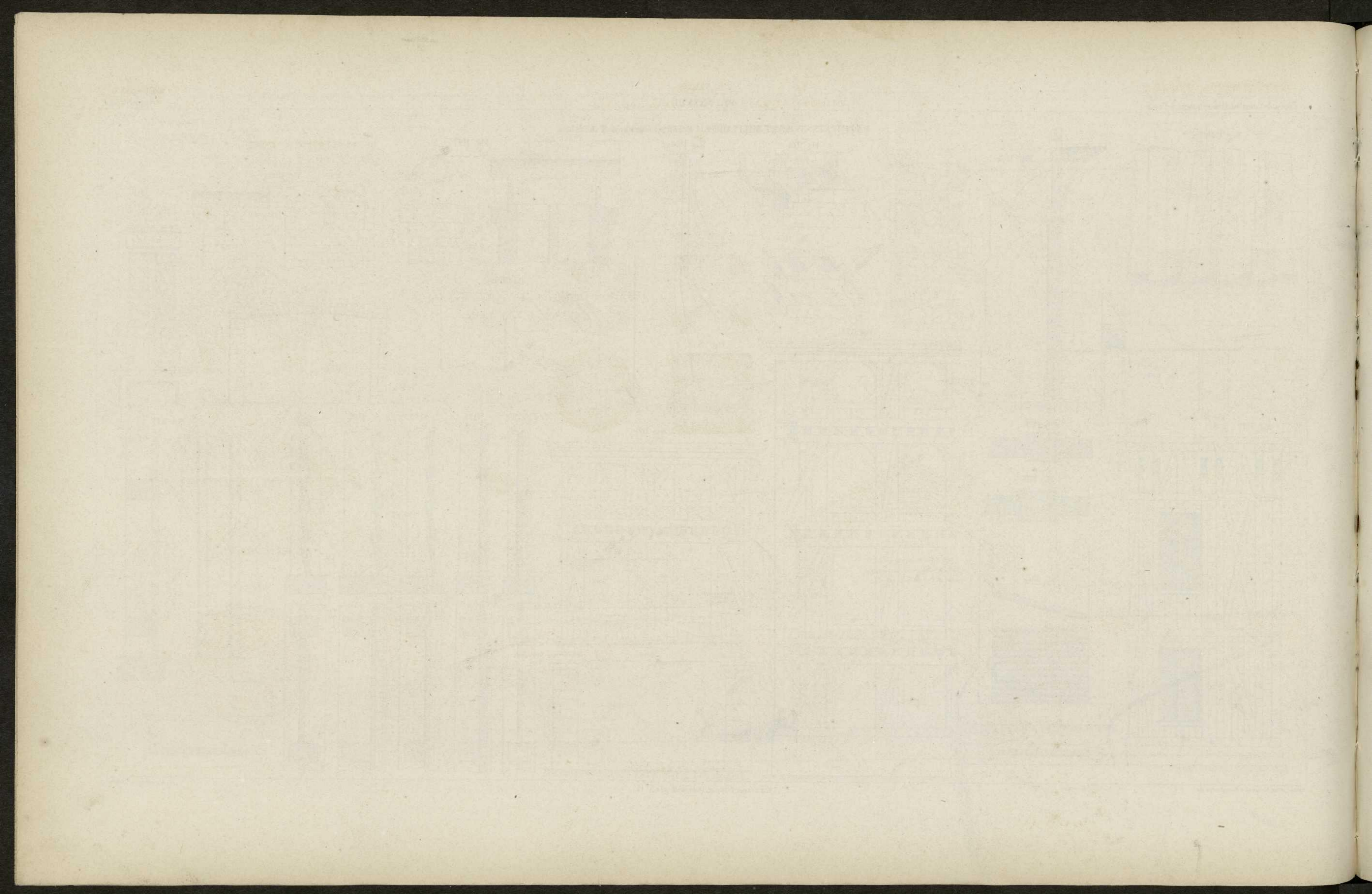


BATIMENTS CIVILS ET MILITAIRES. Soutiens isolés Voutes.



gravé chez Erhard & Bonaparte 42.

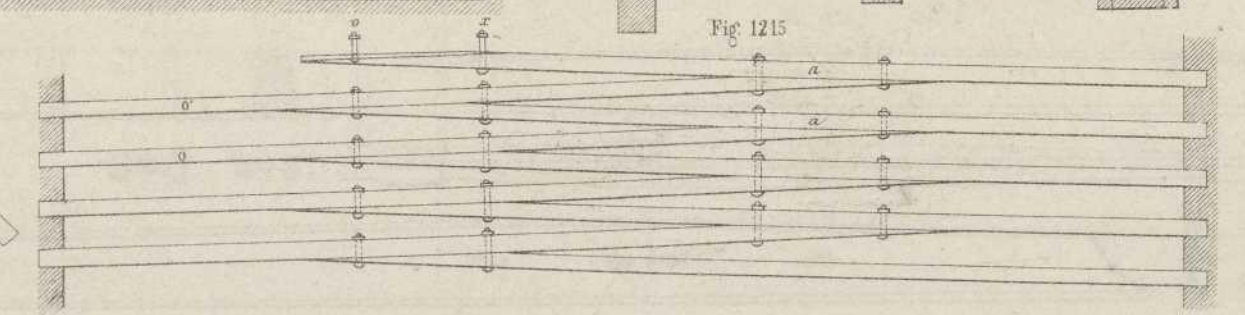
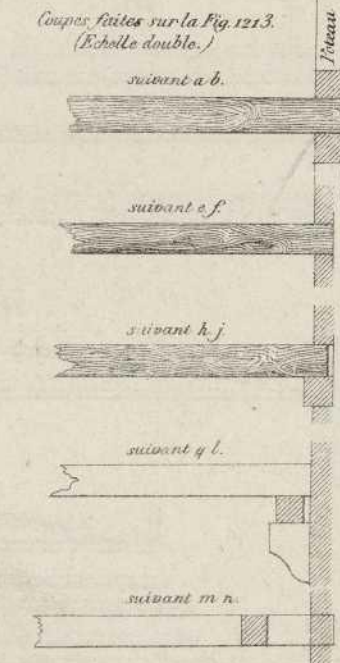
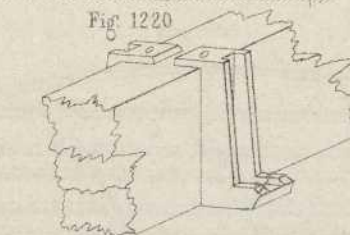
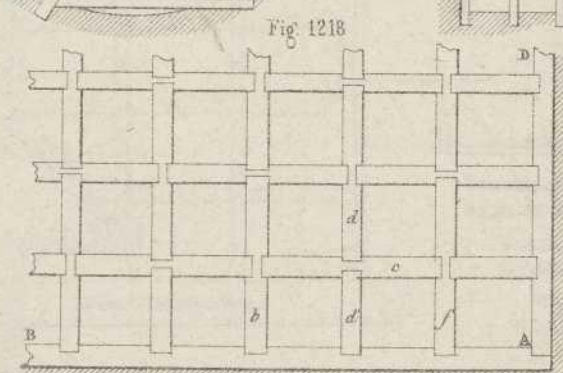
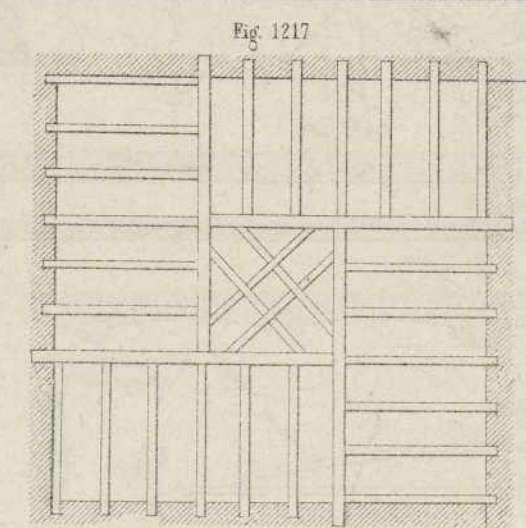
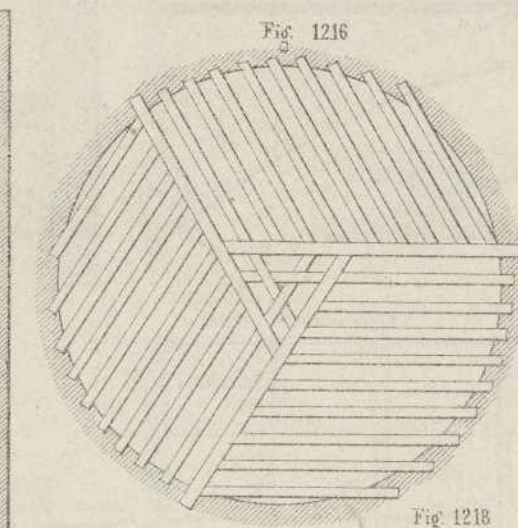
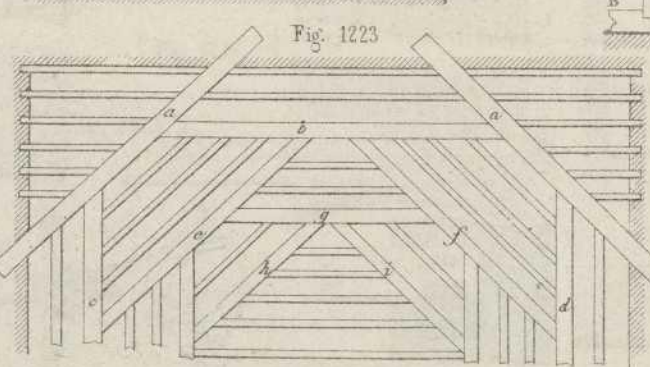
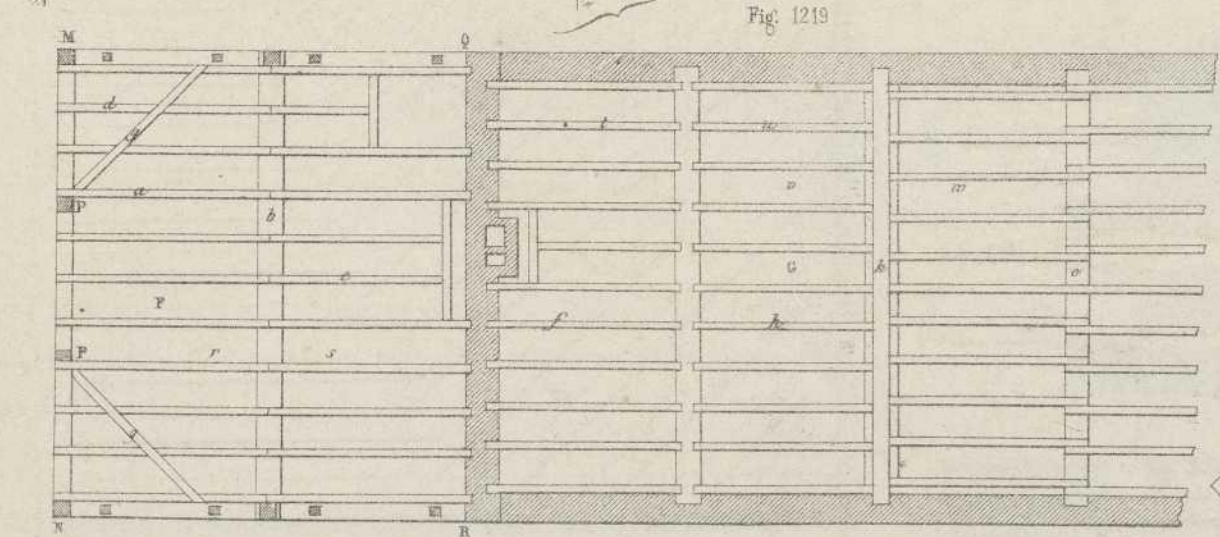
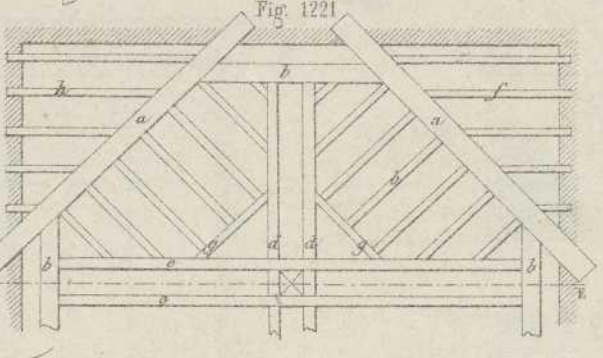
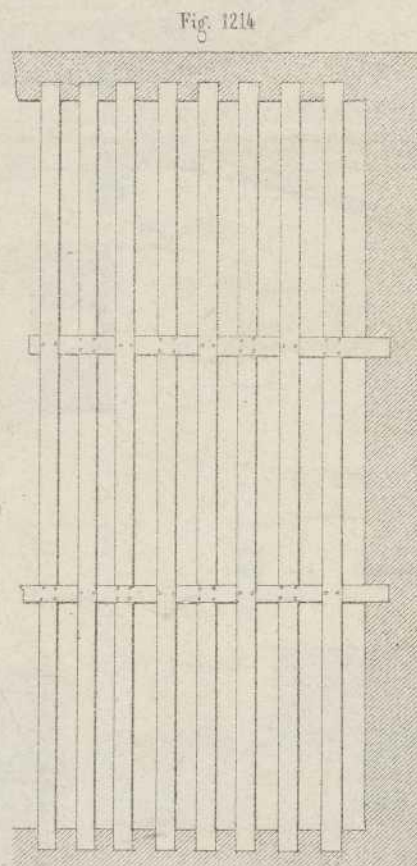
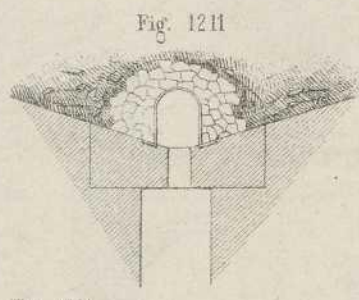
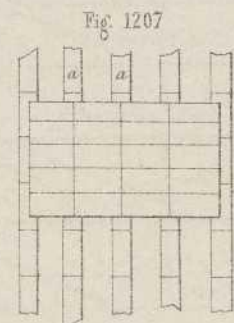
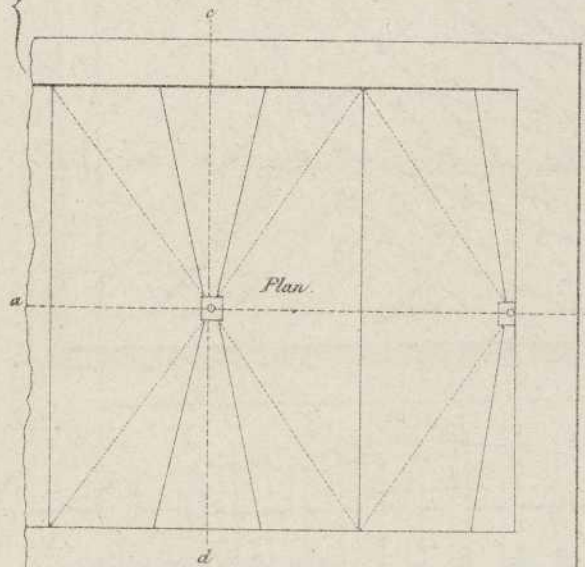
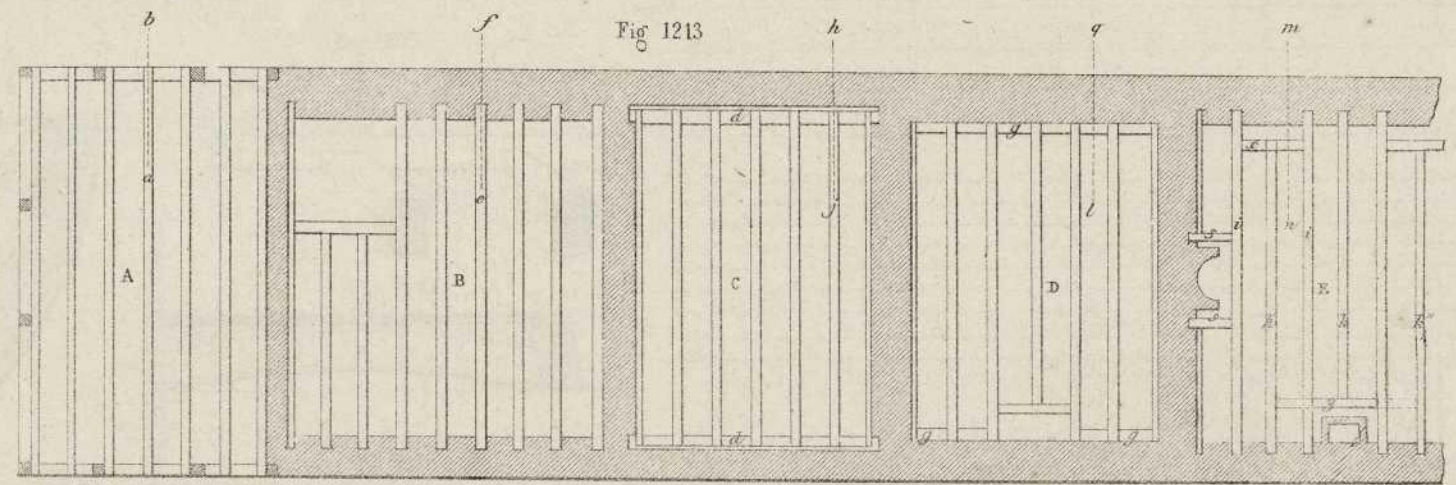
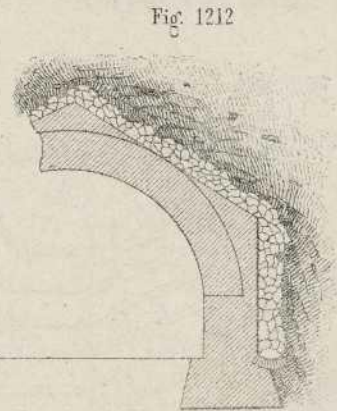
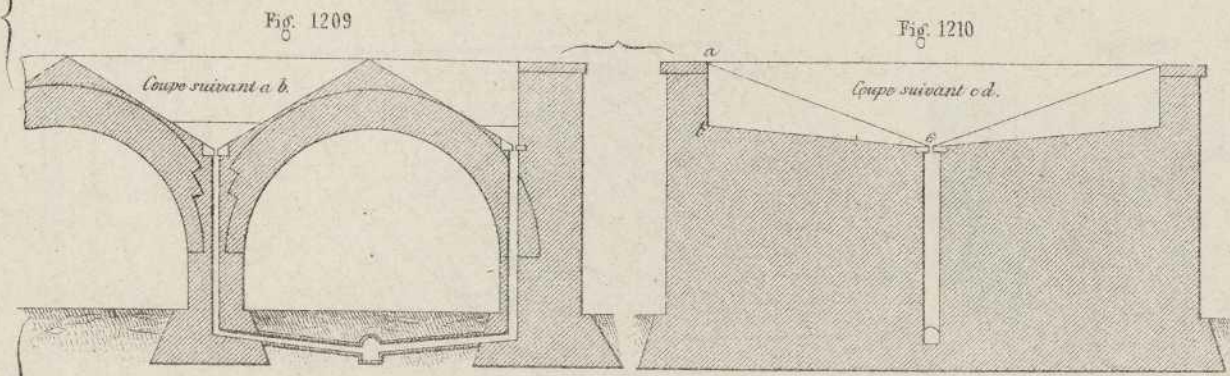






BATIMENTS CIVILS ET MILITAIRES. Voûtes, Planchers.

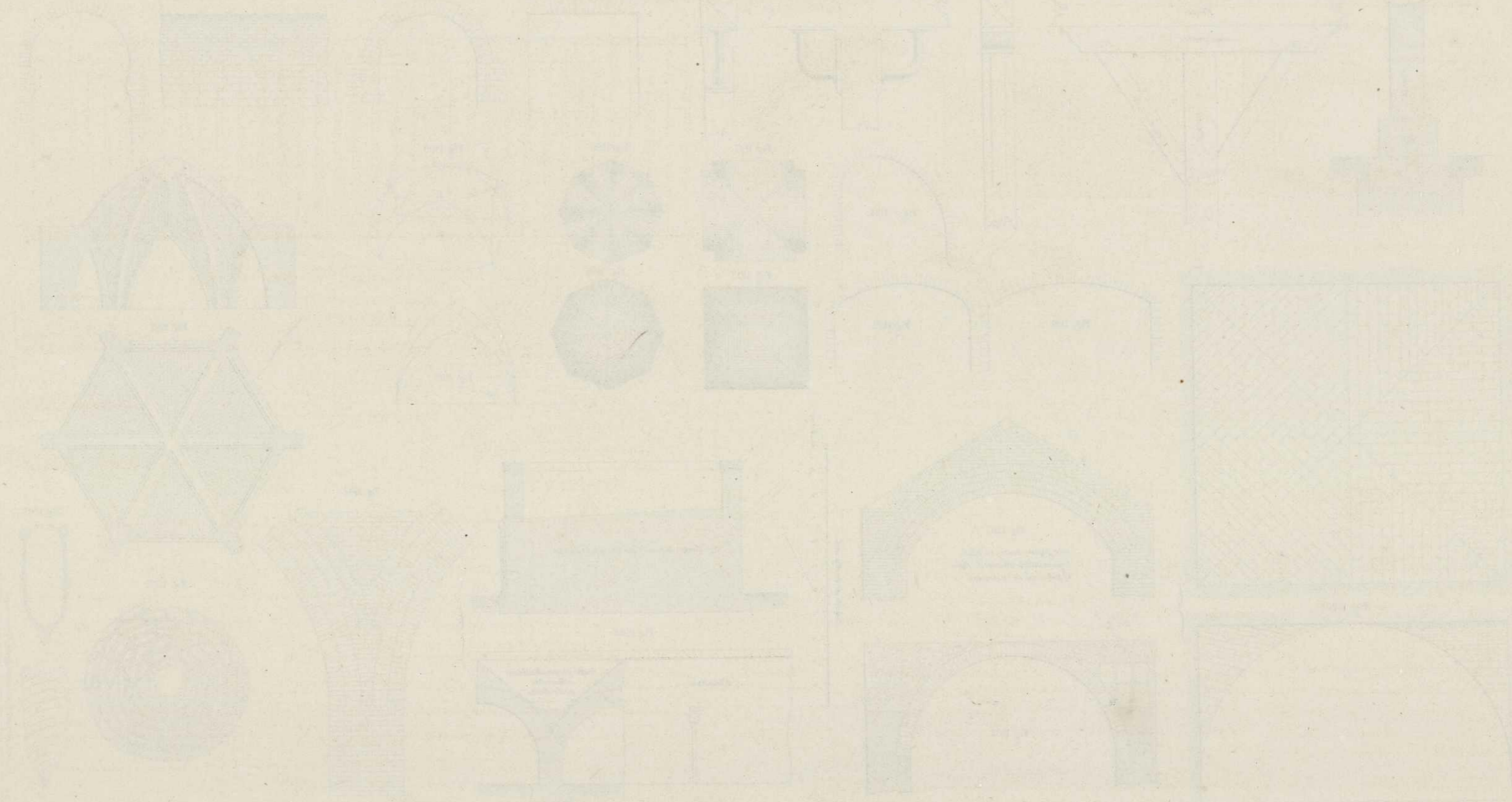
0 1 2 3 4 5 6 7 8 9 10 Mètres





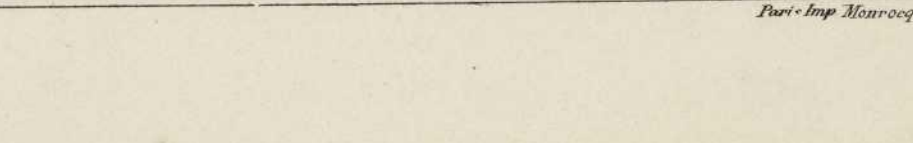
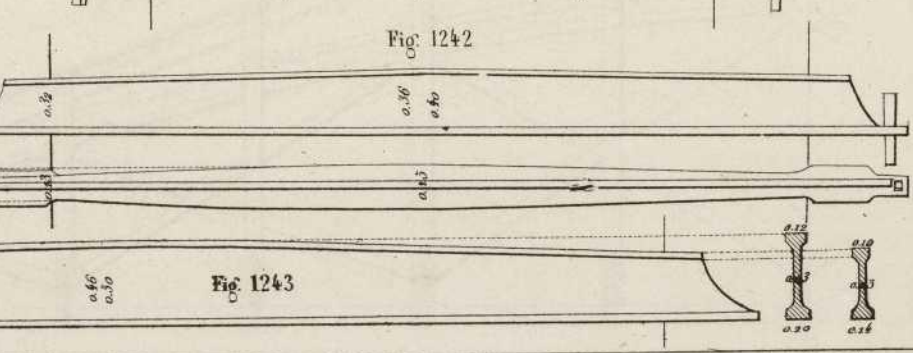
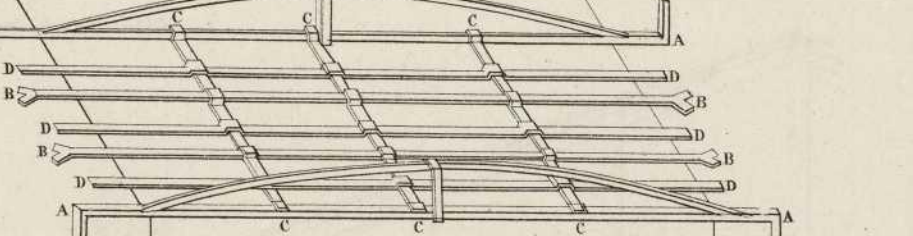
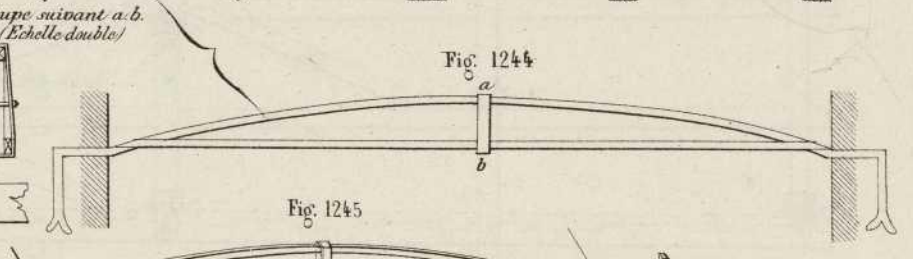
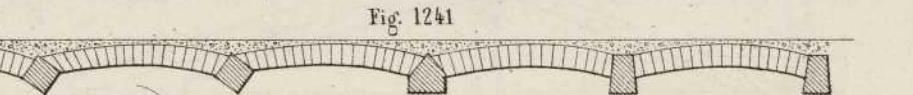
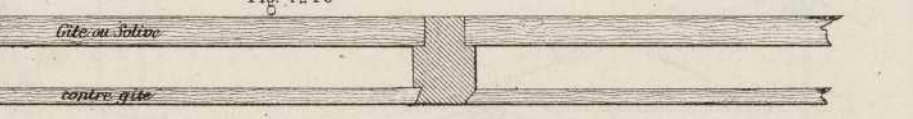
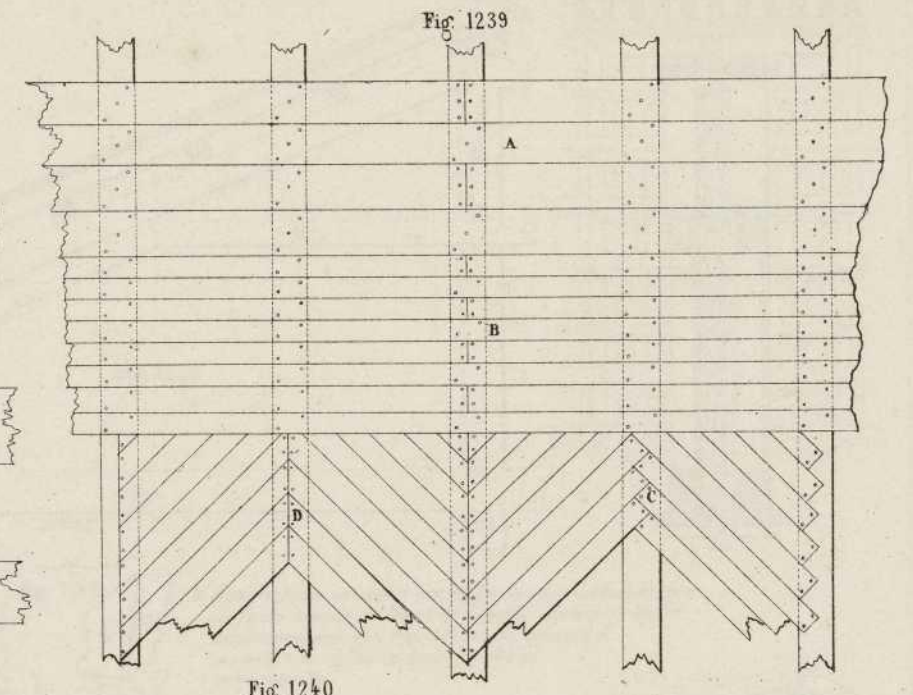
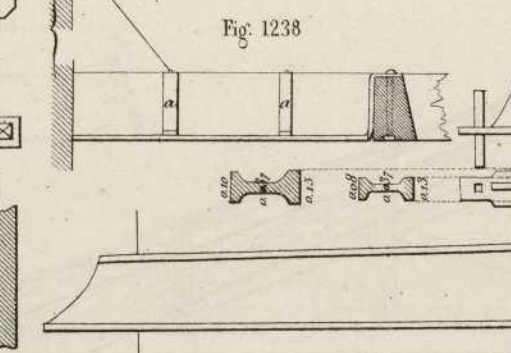
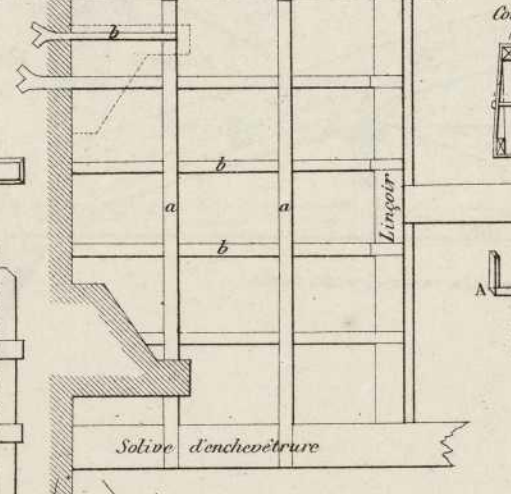
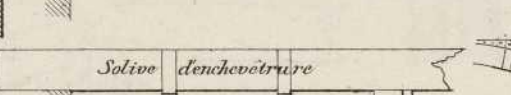
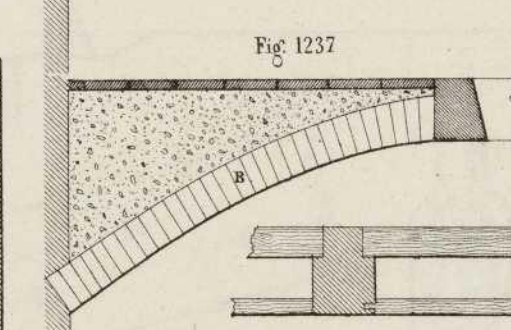
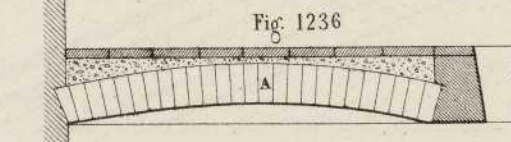
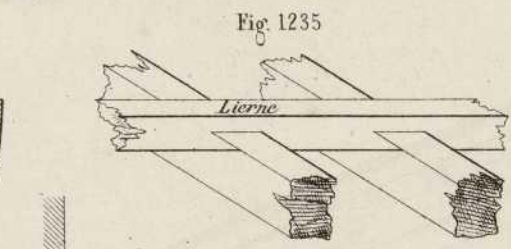
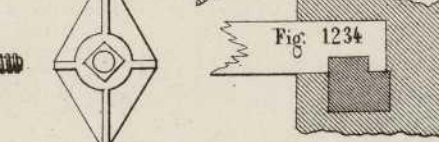
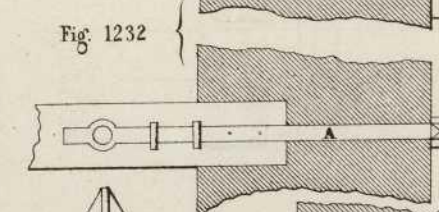
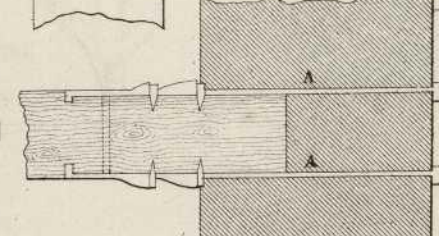
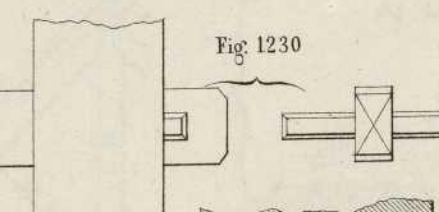
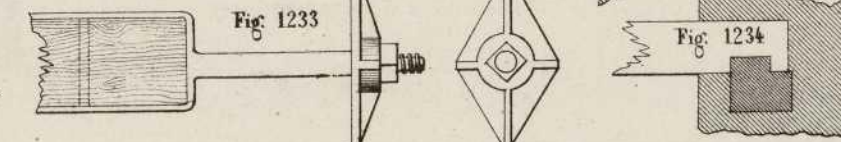
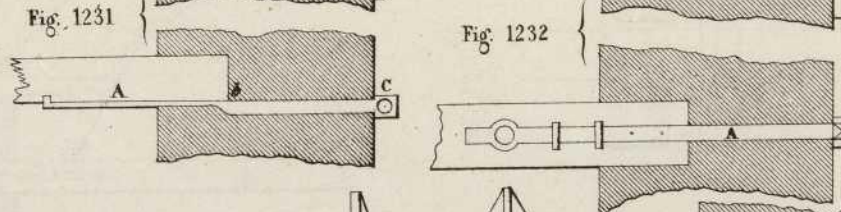
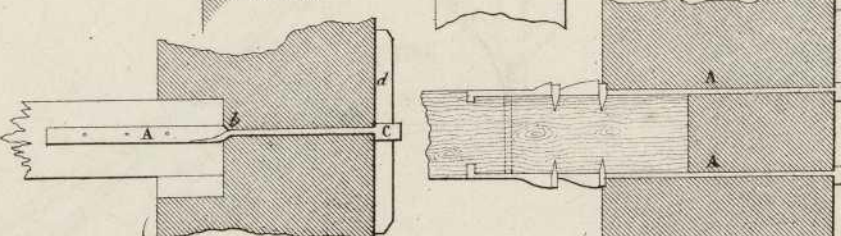
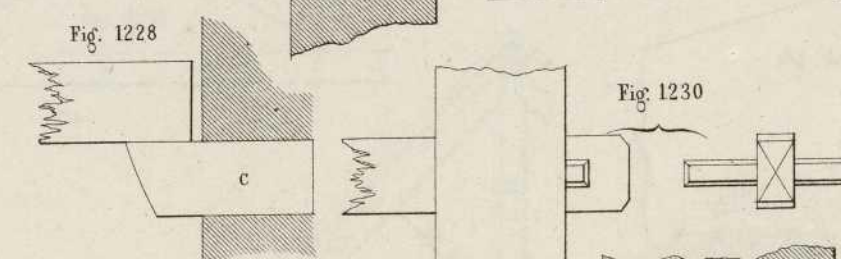
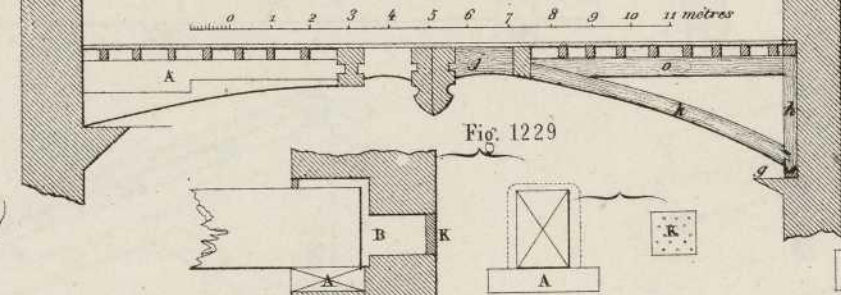
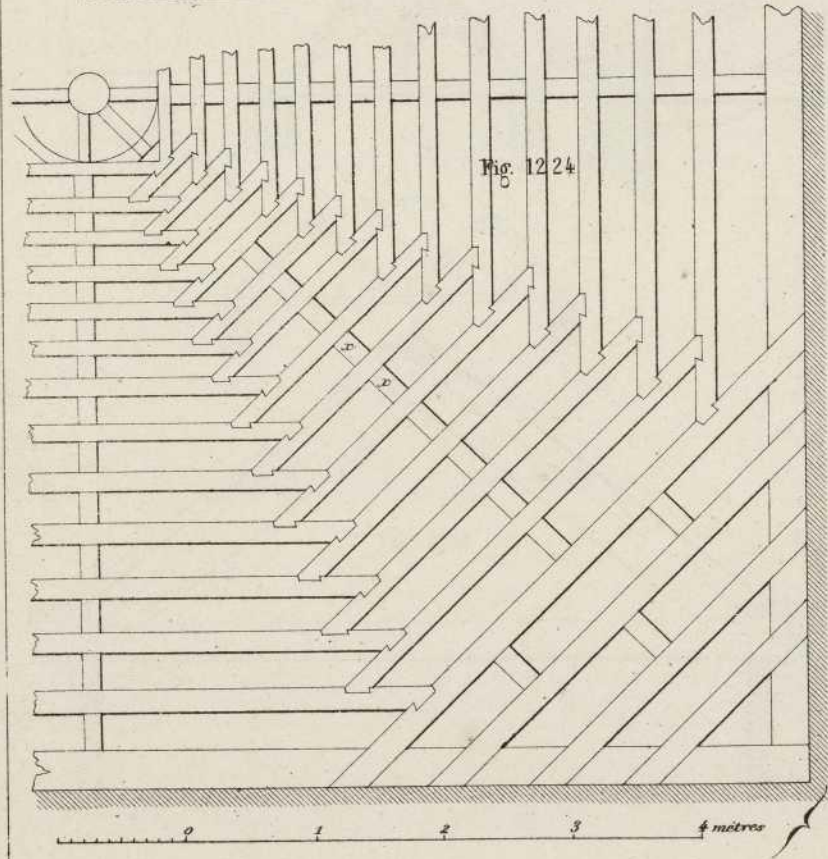
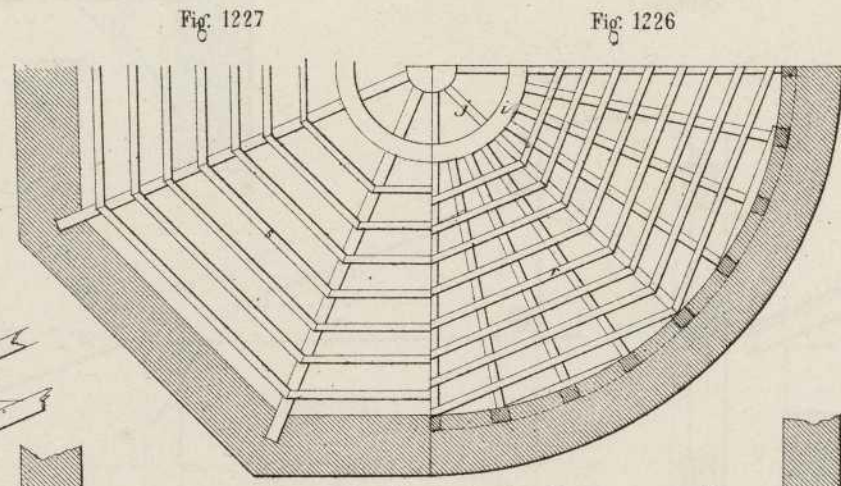
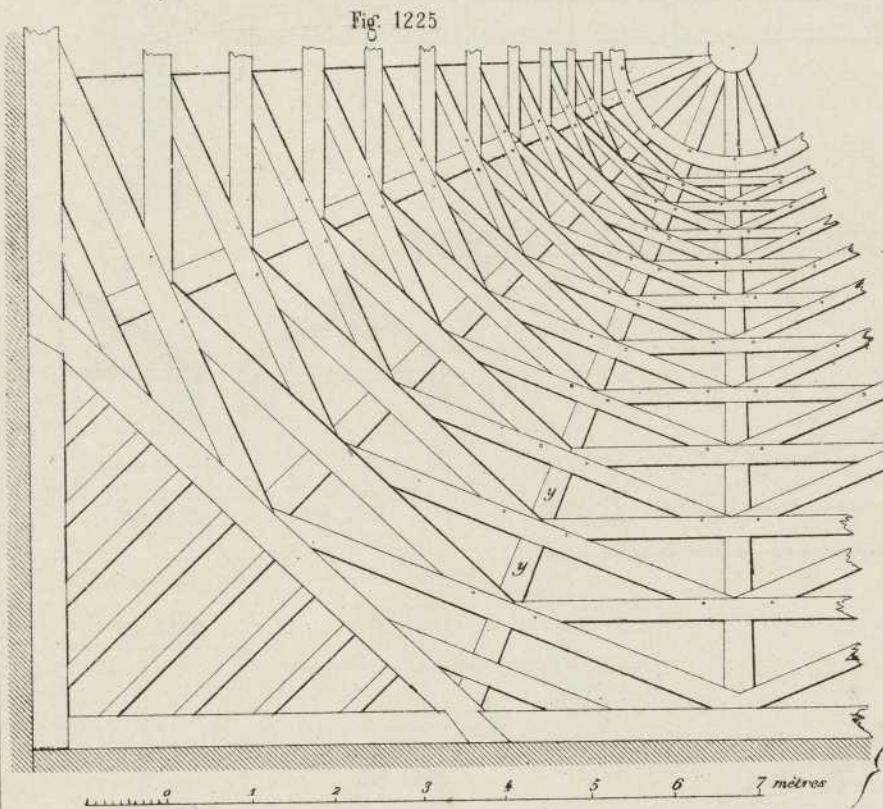
DESIGN OF THE INTERIOR OF THE TEMPLE OF VESTA

DESIGN OF THE INTERIOR OF THE TEMPLE OF VESTA



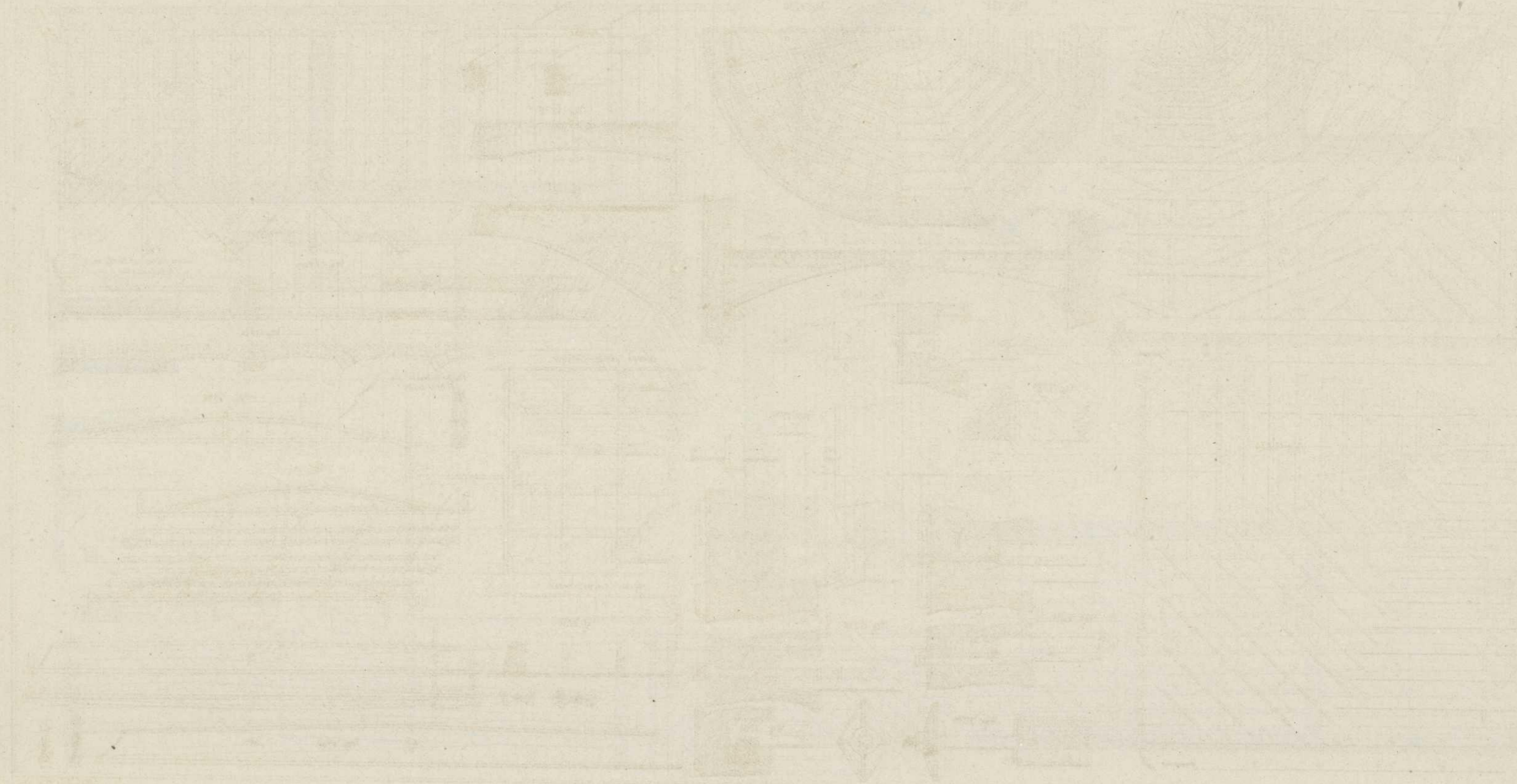


BATIMENTS CIVILS ET MILITAIRES. Planchers.



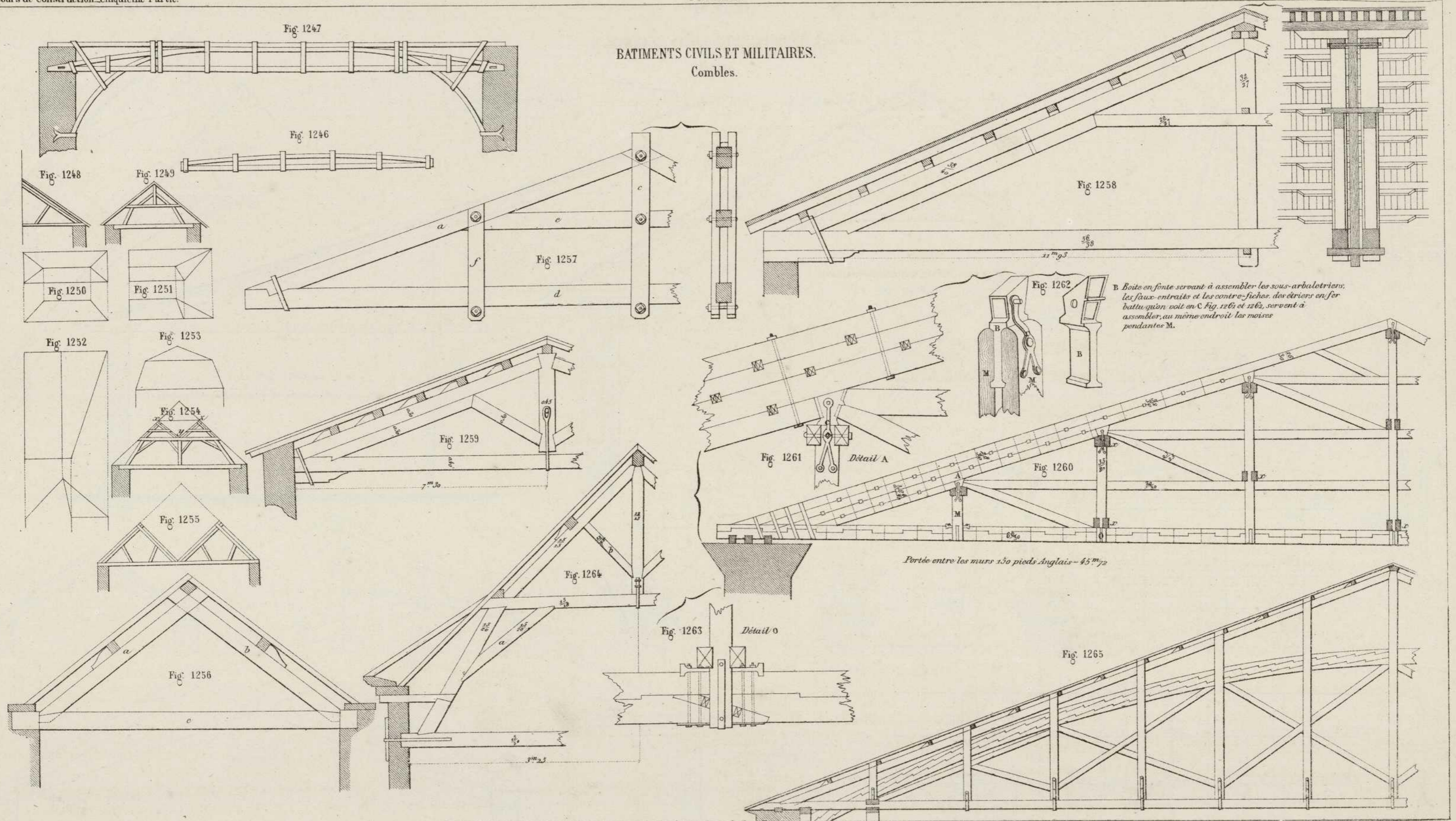


THE UNIVERSITY OF CHICAGO  
LIBRARY

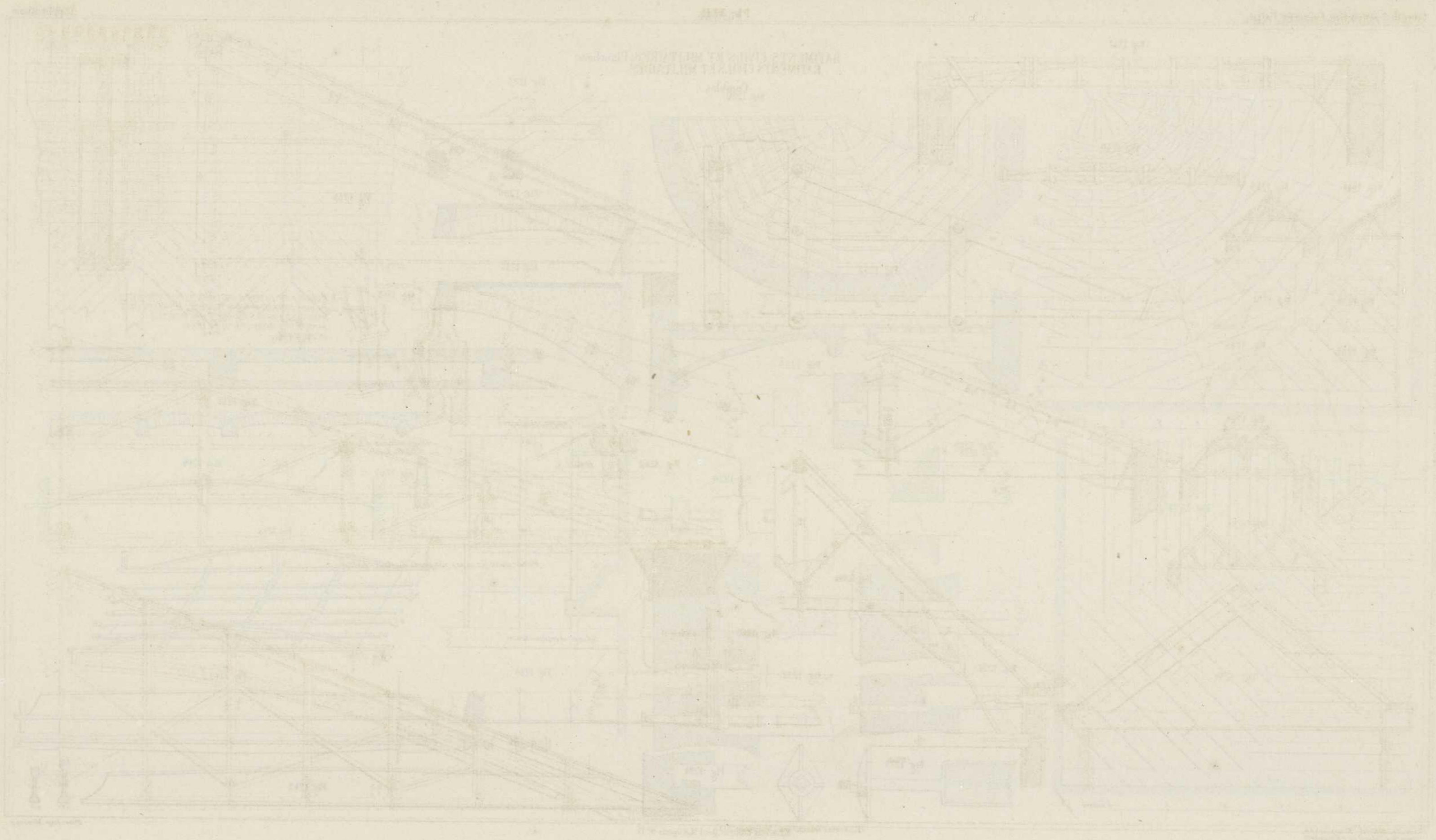




BATIMENTS CIVILS ET MILITAIRES.  
Combles.



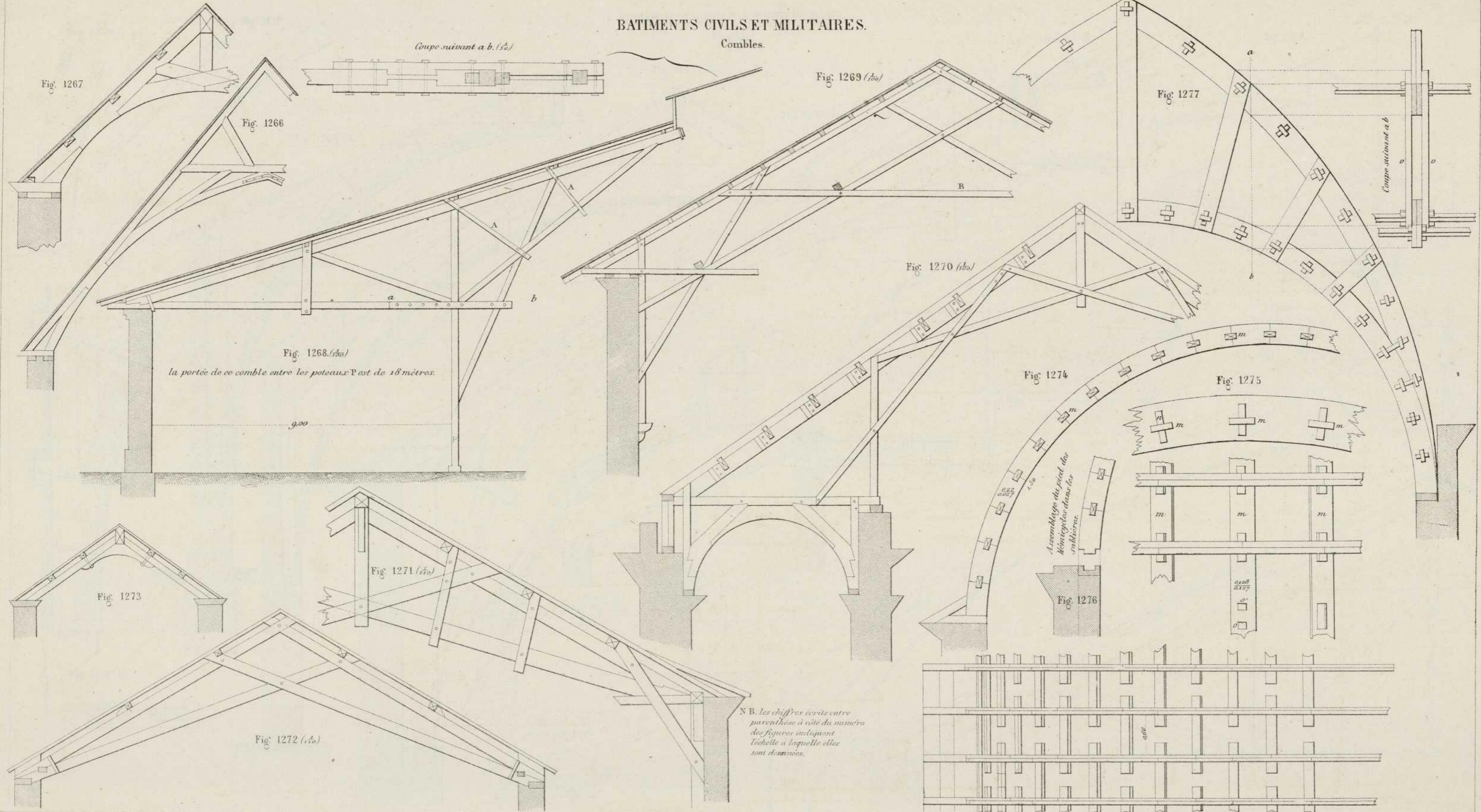




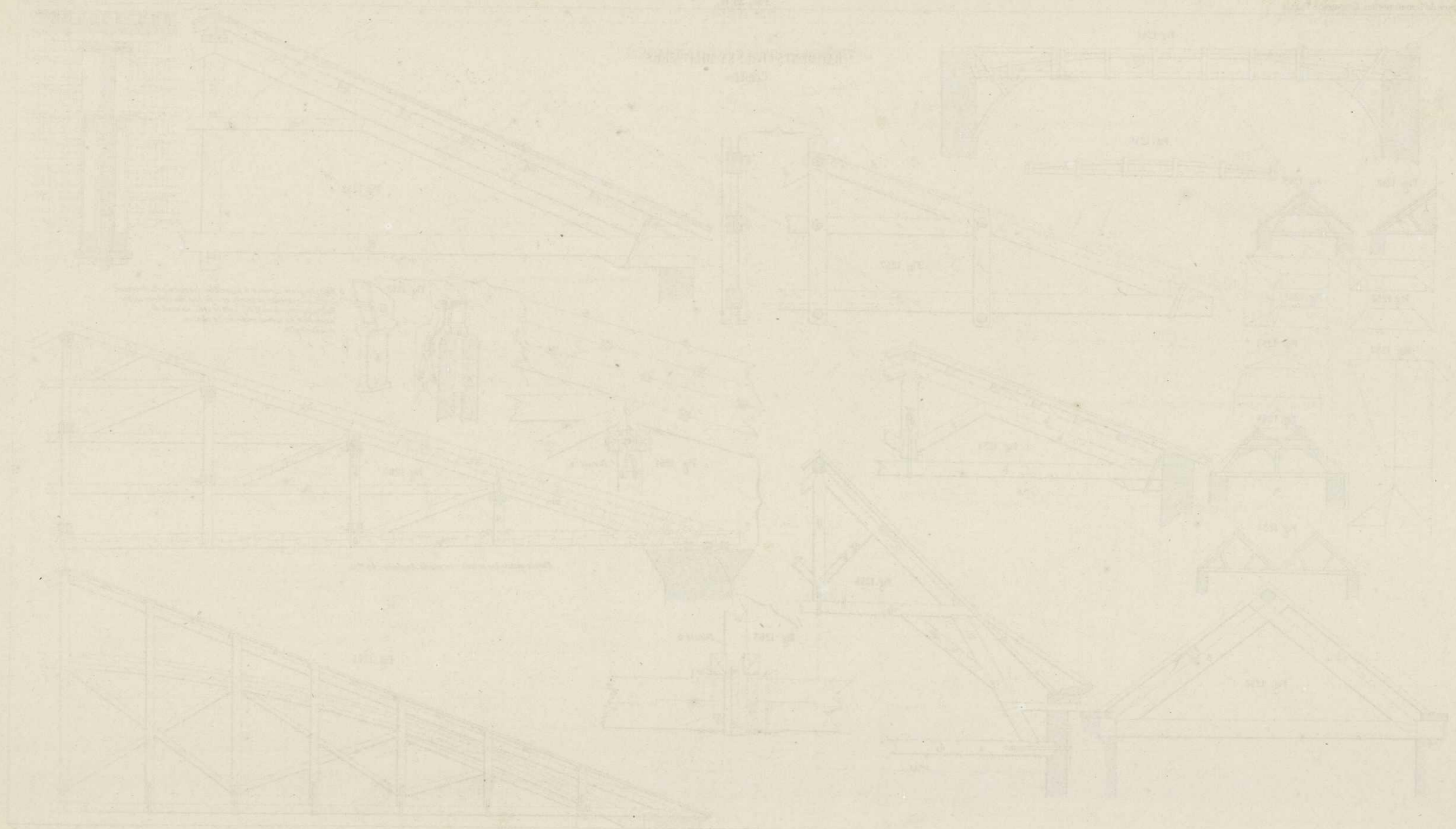


BATIMENTS CIVILS ET MILITAIRES.

Combles.

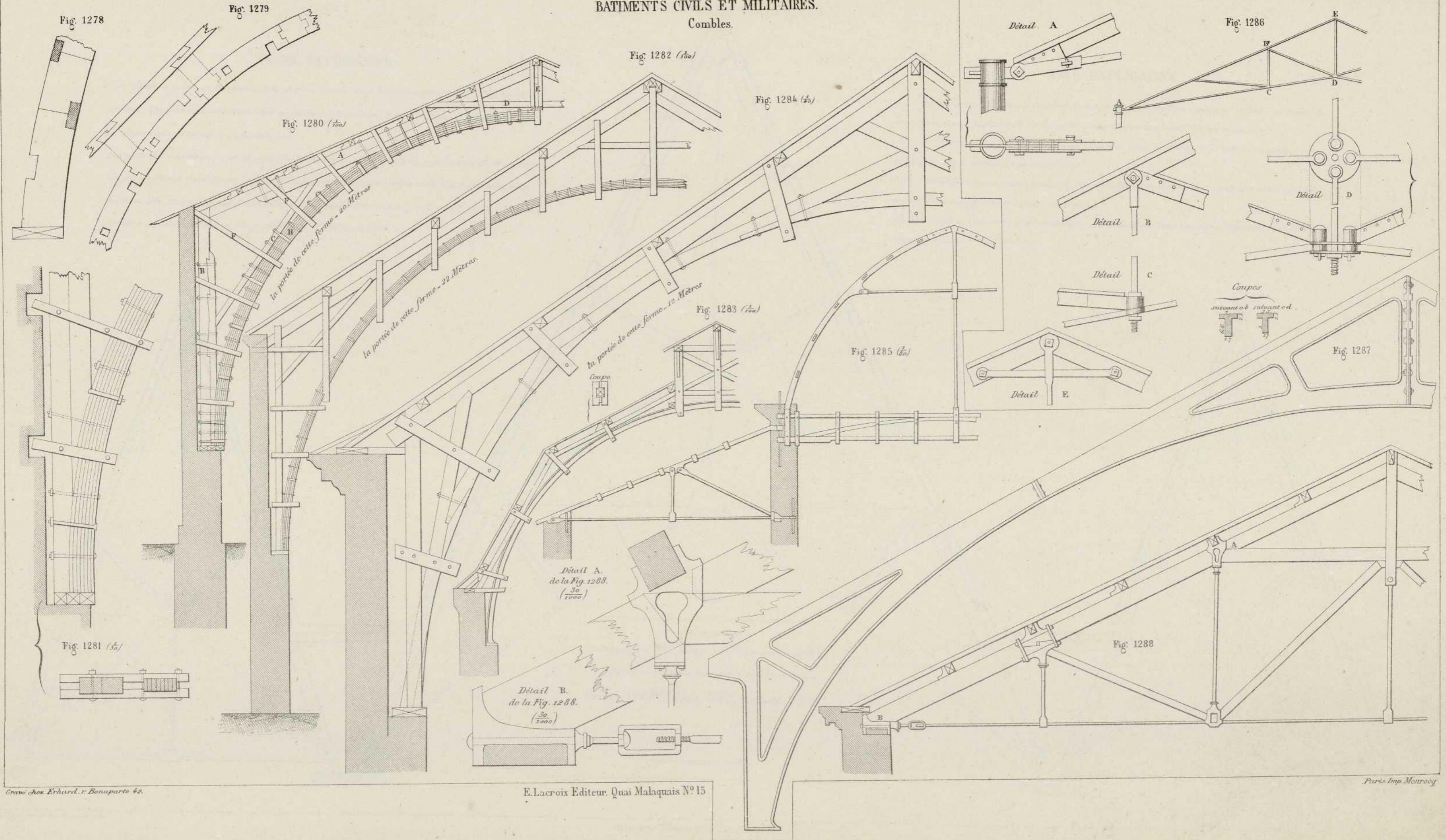






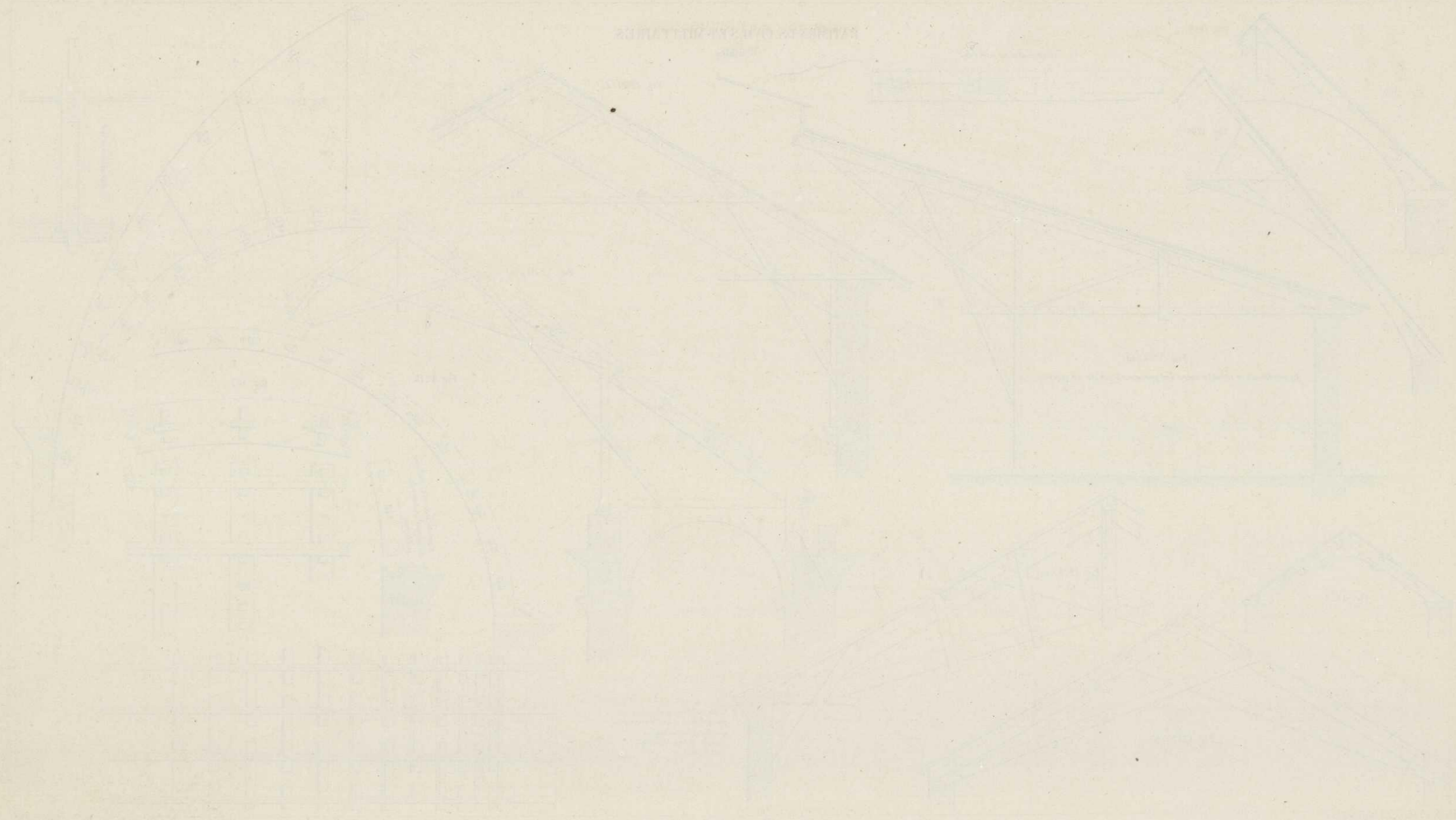


BATIMENTS CIVILS ET MILITAIRES.  
Combles.





PLAN OF THE TEMPLE



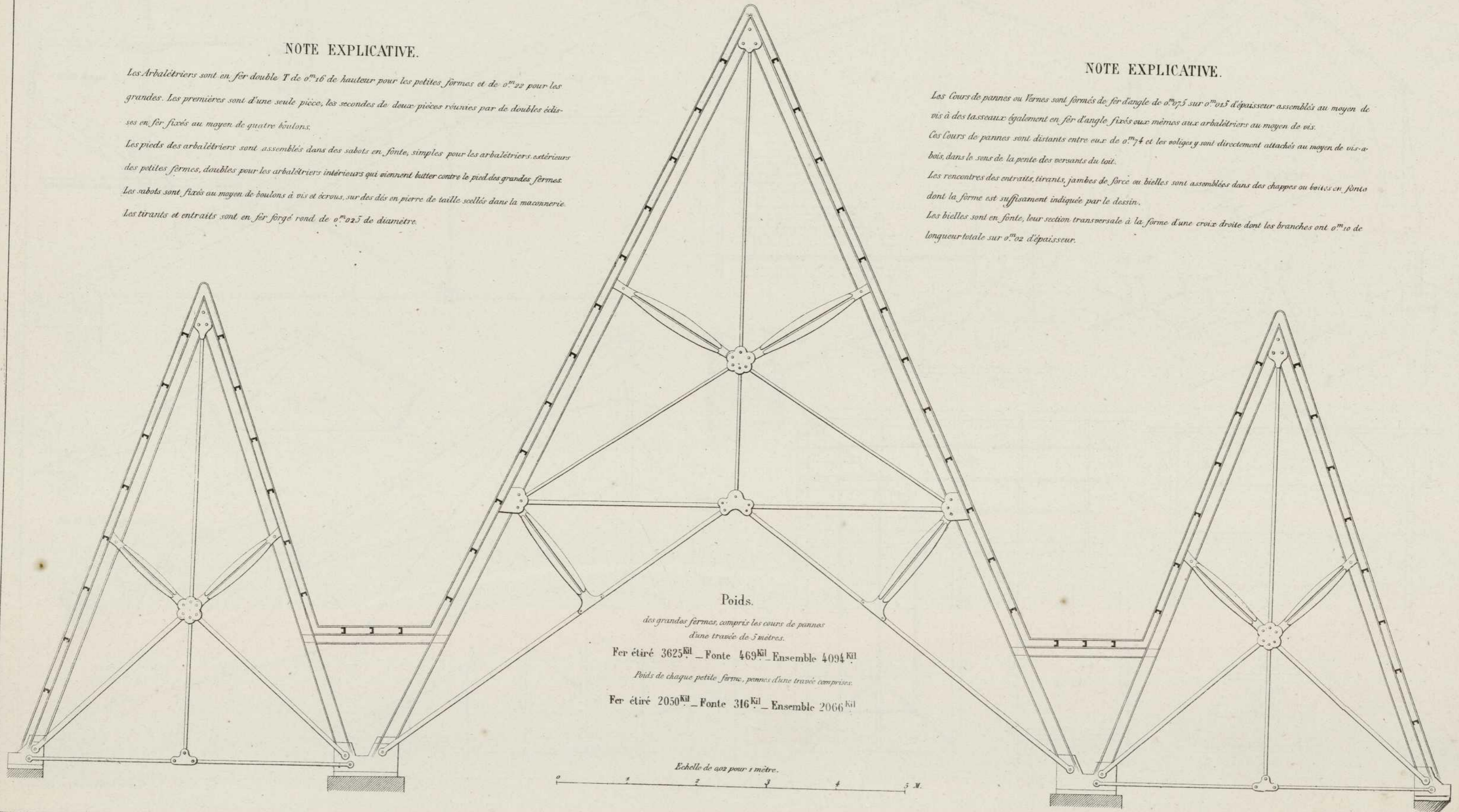


NOTE EXPLICATIVE.

Les Arbalétriers sont en fer double T de 0<sup>m</sup>.16 de hauteur pour les petites formes et de 0<sup>m</sup>.22 pour les grandes. Les premières sont d'une seule pièce, les secondes de deux pièces réunies par de doubles écrous en fer fixés au moyen de quatre boulons.  
 Les pieds des arbalétriers sont assemblés dans des sabots en fonte, simples pour les arbalétriers extérieurs des petites formes, doubles pour les arbalétriers intérieurs qui viennent butter contre le pied des grandes formes.  
 Les sabots sont fixés au moyen de boulons à vis et écrous, sur des dés en pierre de taille scellés dans la maçonnerie.  
 Les tirants et entrants sont en fer forgé rond de 0<sup>m</sup>.025 de diamètre.

NOTE EXPLICATIVE.

Les Cours de pannes ou Yernes sont formés de fer d'angle de 0<sup>m</sup>.075 sur 0<sup>m</sup>.015 d'épaisseur assemblés au moyen de vis à des tasseaux également en fer d'angle fixés eux mêmes aux arbalétriers au moyen de vis.  
 Les Cours de pannes sont distants entre eux de 0<sup>m</sup>.74 et les voliges y sont directement attachés au moyen de vis-à-bois, dans le sens de la pente des versants du toit.  
 Les rencontres des entrants, tirants, jambes de force ou bielles sont assemblées dans des chappes ou boîtes en fonte dont la forme est suffisamment indiquée par le dessin.  
 Les bielles sont en fonte, leur section transversale à la forme d'une croix droite dont les branches ont 0<sup>m</sup>.10 de longueur totale sur 0<sup>m</sup>.02 d'épaisseur.



Poids.

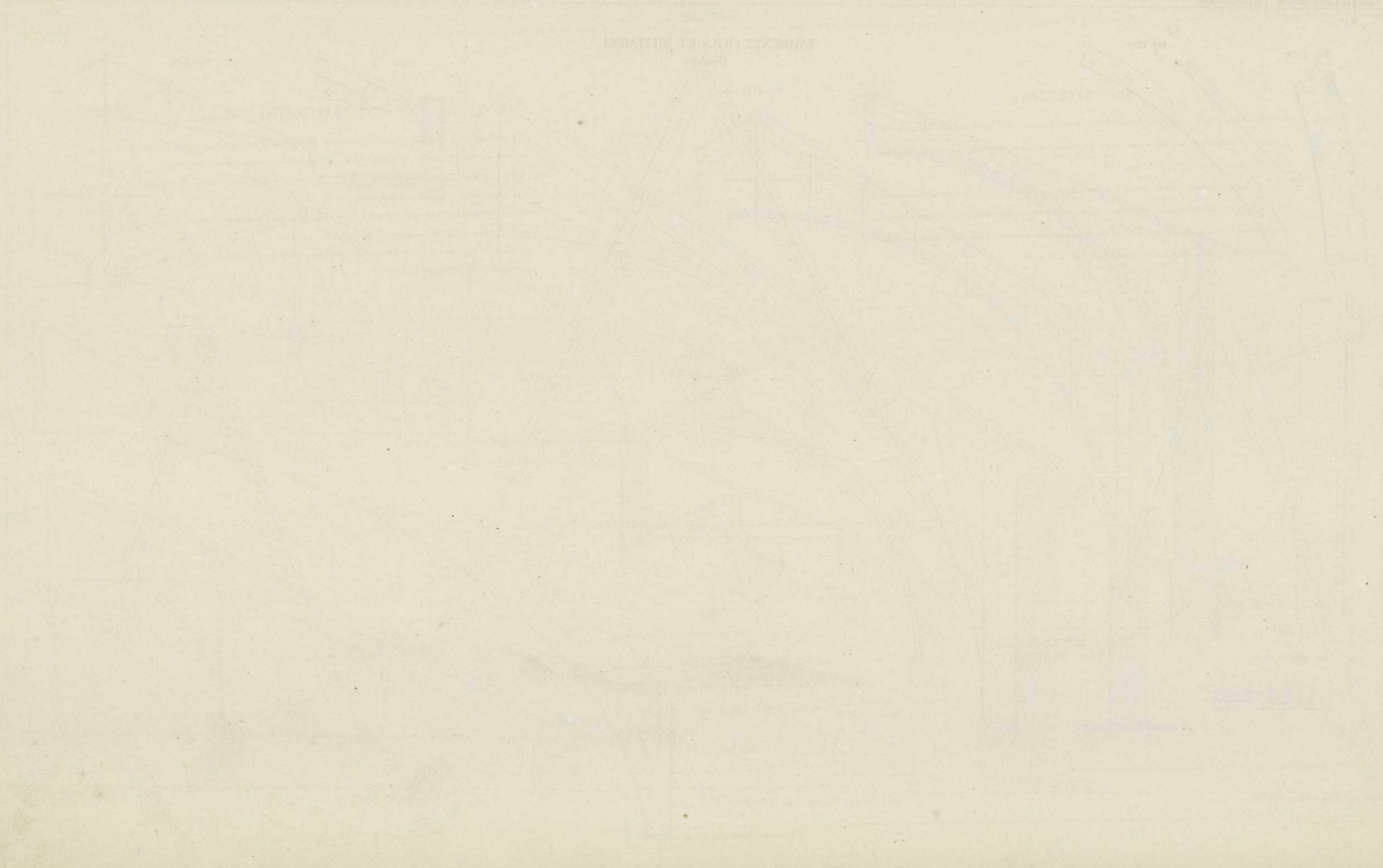
des grandes formes, compris les cours de pannes  
 d'une travée de 5 mètres.  
 Fer étiré 3625<sup>Kil</sup> - Fonte 469<sup>Kil</sup> - Ensemble 4094<sup>Kil</sup>  
 Poids de chaque petite forme, pannes d'une travée comprises.  
 Fer étiré 2050<sup>Kil</sup> - Fonte 316<sup>Kil</sup> - Ensemble 2066<sup>Kil</sup>

Echelle de 402 pour 1 mètre.



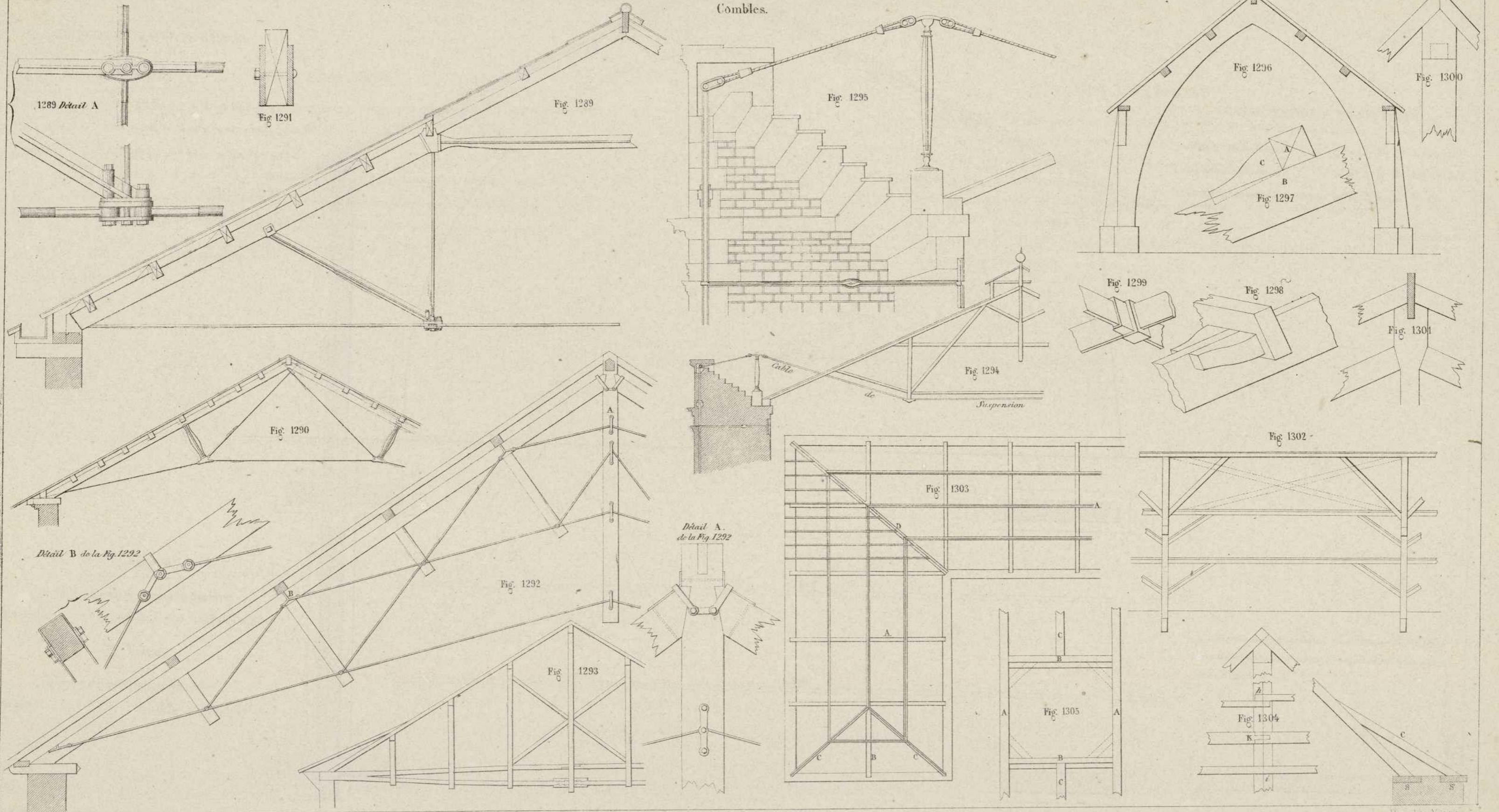


PLATE I





BATIMENTS CIVILS ET MILITAIRES.  
Combles.



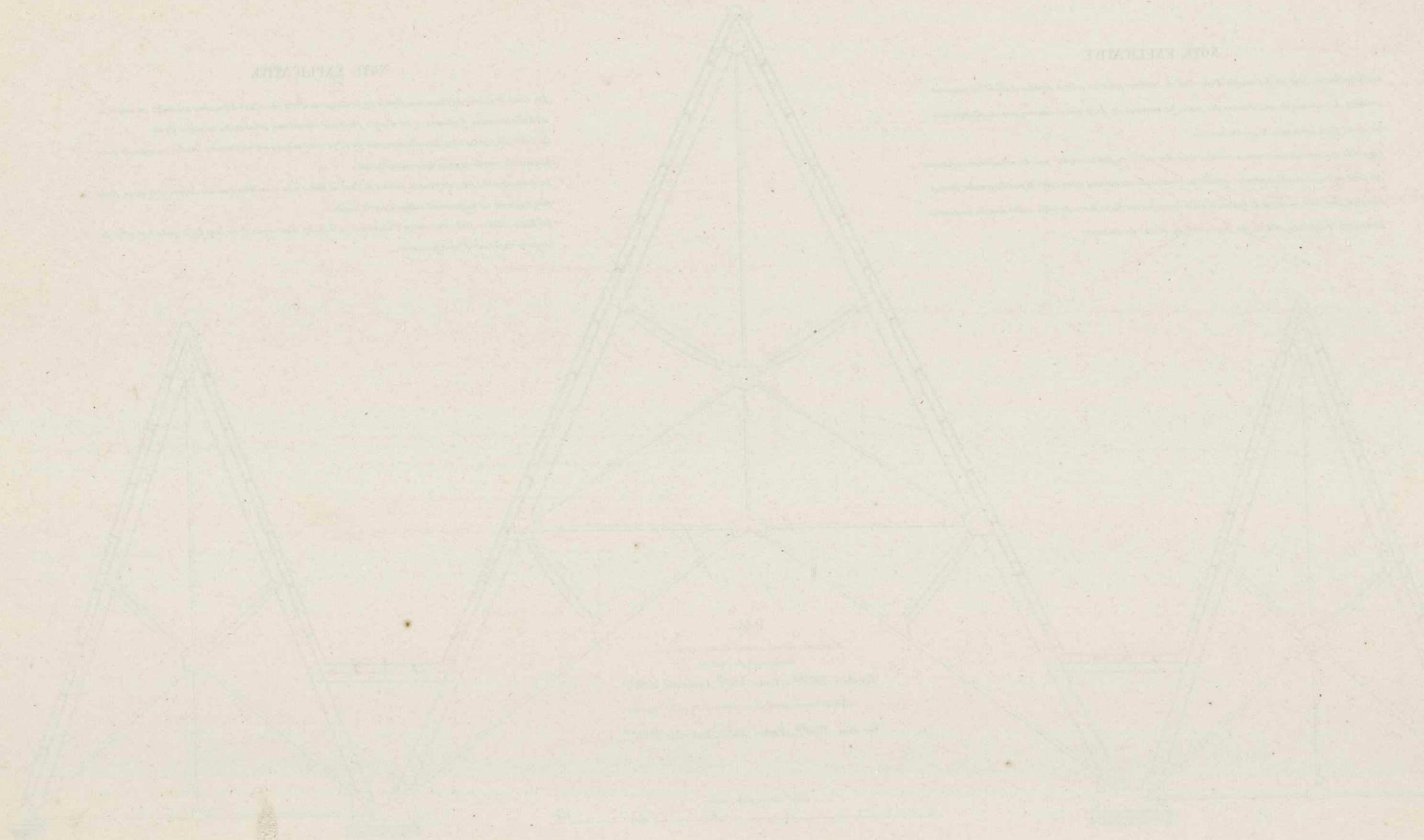


NOTE RELATIVE

Faint, illegible text block on the right side of the page, likely providing additional information or instructions related to the diagram.

NOTE EXPLANATORY

Faint, illegible text block on the left side of the page, likely providing additional information or instructions related to the diagram.



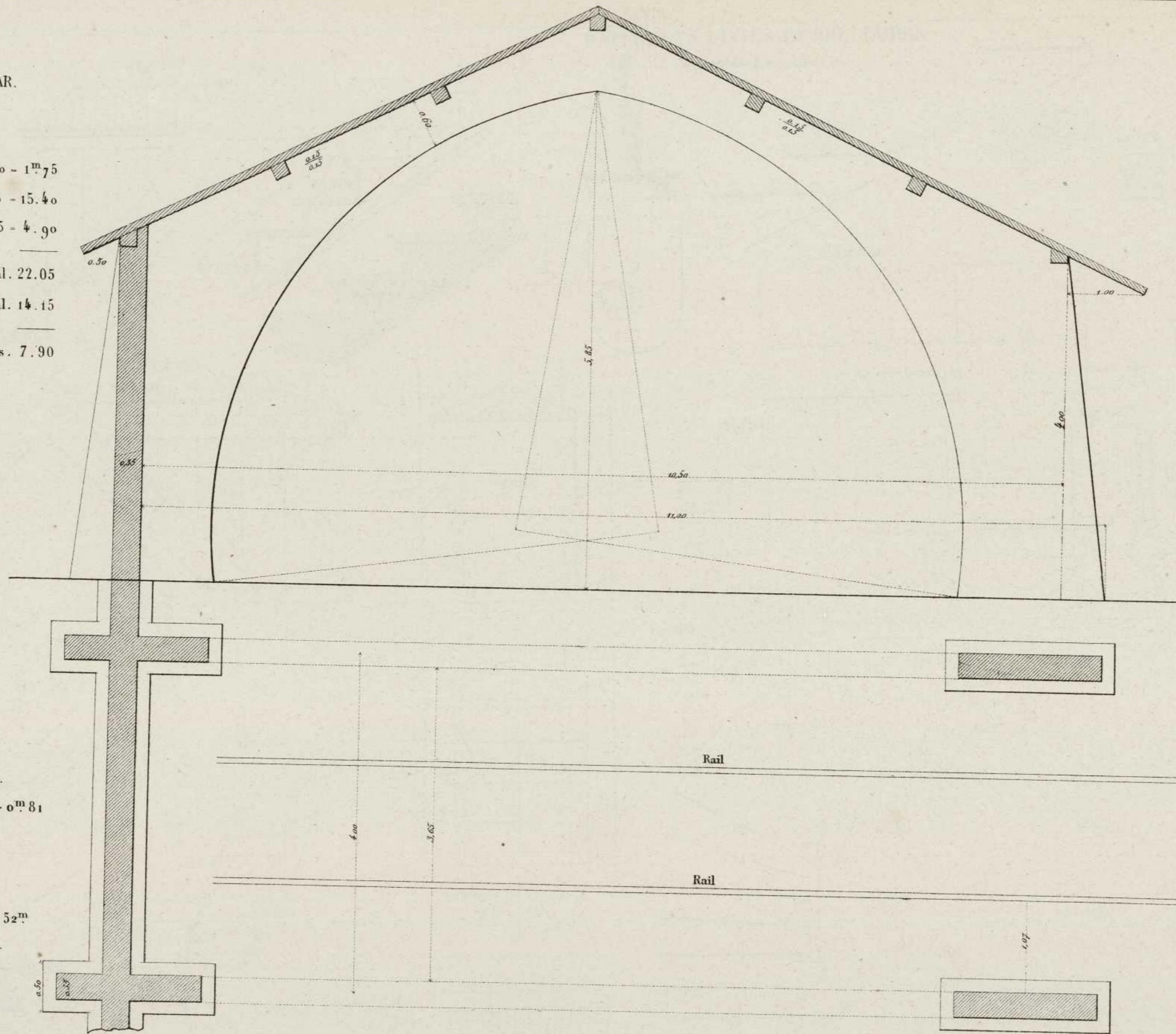
Faint text located below the main diagram, possibly a title or a reference number.



MÈTRE D'UNE TRAVÉE DE HANGAR.

1° Maçonneries.

Fondations	3 <sup>m</sup> .50 x 1.00 x 0 <sup>m</sup> .50 = 1 <sup>m</sup> .75
Pieds droits	11.00 x 4.00 x 0.35 = 15.40
Pignon	10.00 x 1.40 x 0.35 = 4.90
	<hr/> Total. 22.05
	à déduire le vide ogival. 14.15
	<hr/> Reste m. cubes. 7.90



DÉTAIL ESTIMATIF D'UNE TRAVÉE.

Maçonnerie en briques	7 <sup>m</sup> .90 à F. 14 - F. 110.00
Charpente en sapin	0 <sup>m</sup> .81 à F. 80 - F. 64.80
Couverture en tuiles tout compris	52 <sup>m</sup> .00 à F. 250 - F. 130.00
	<hr/> Total. 304.80

2° Charpente.

1 Faite, 4 Cours de pannes, 2 Sablières.

Ensemble	30 <sup>m</sup> .30 x 0.15 x 0 <sup>m</sup> .18 = 0 <sup>m</sup> .81
----------	--

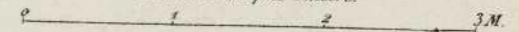
3° Toiture.

Longueur déployée suivant les pentes

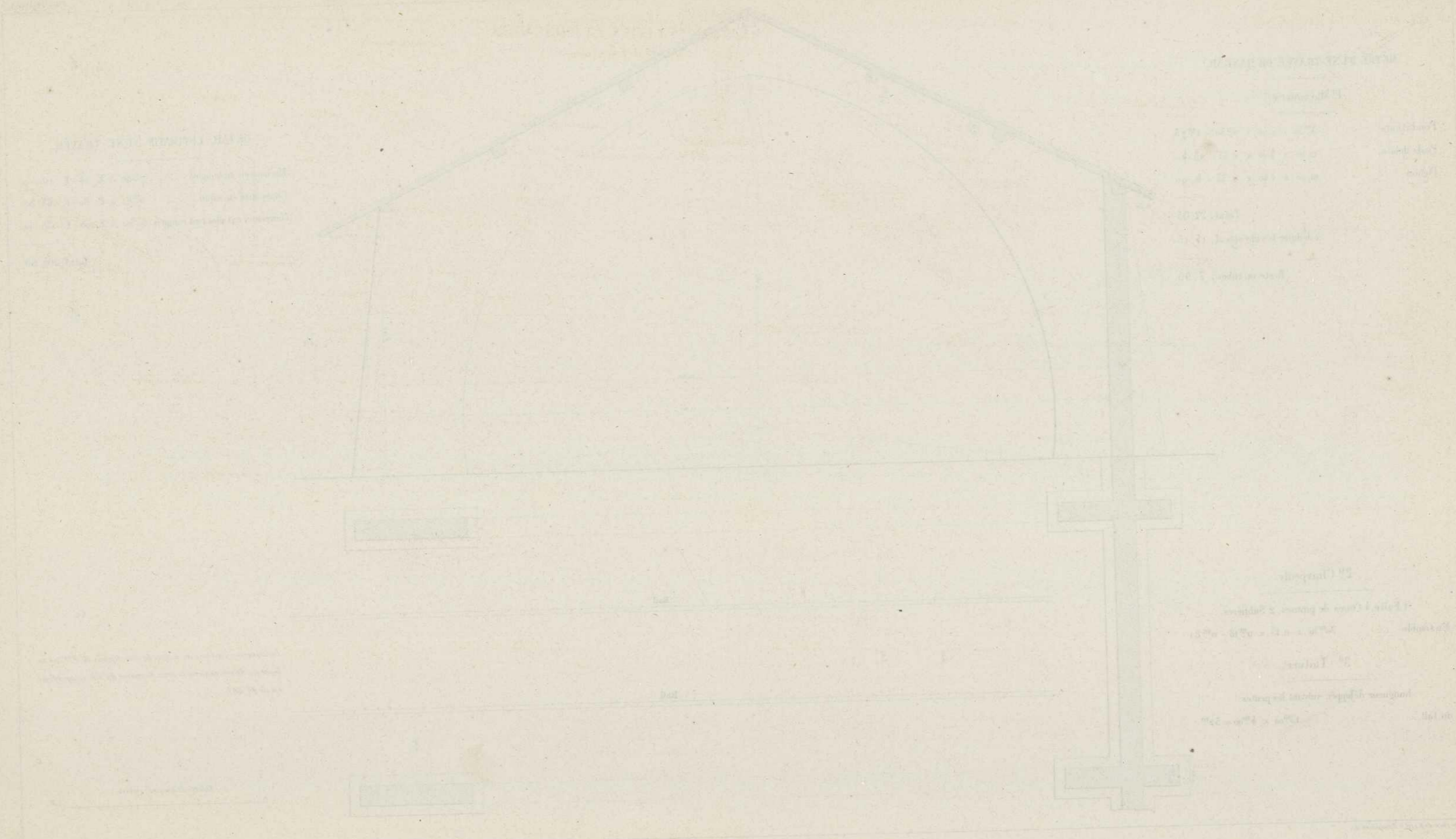
du toit	13 <sup>m</sup> .00 x 4 <sup>m</sup> .00 = 52 <sup>m</sup>
---------	--

La superficie couverte au moyen de cette dépense de F<sup>cs</sup> 304.80 étant de 46 mètres carrés le prix de revient du mètre superficiel est de F<sup>cs</sup> 663.

Echelle de 0.02 pour 1 mètre.





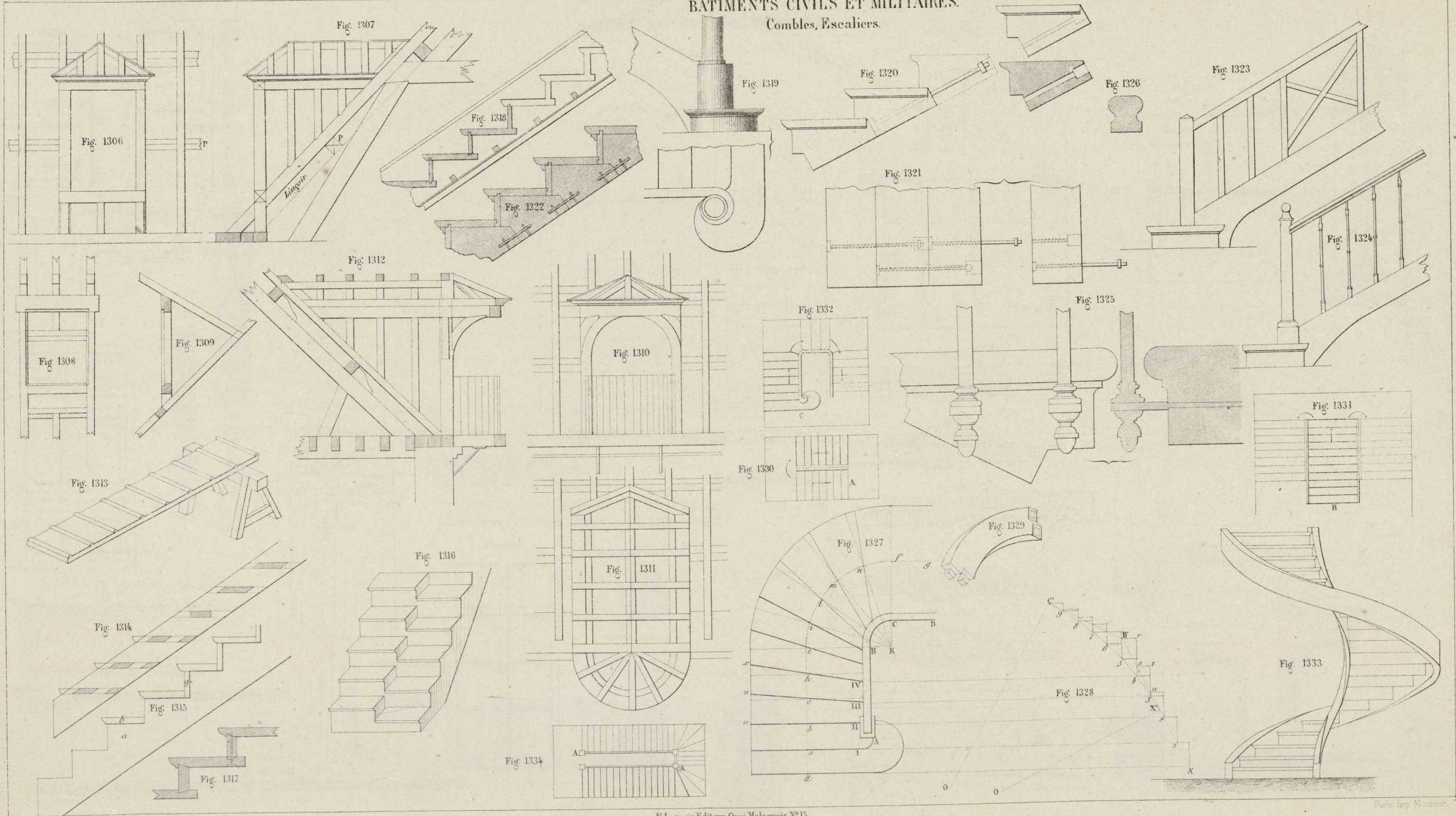


Architectural notes and specifications, including dimensions and material descriptions, located on the right side of the page.

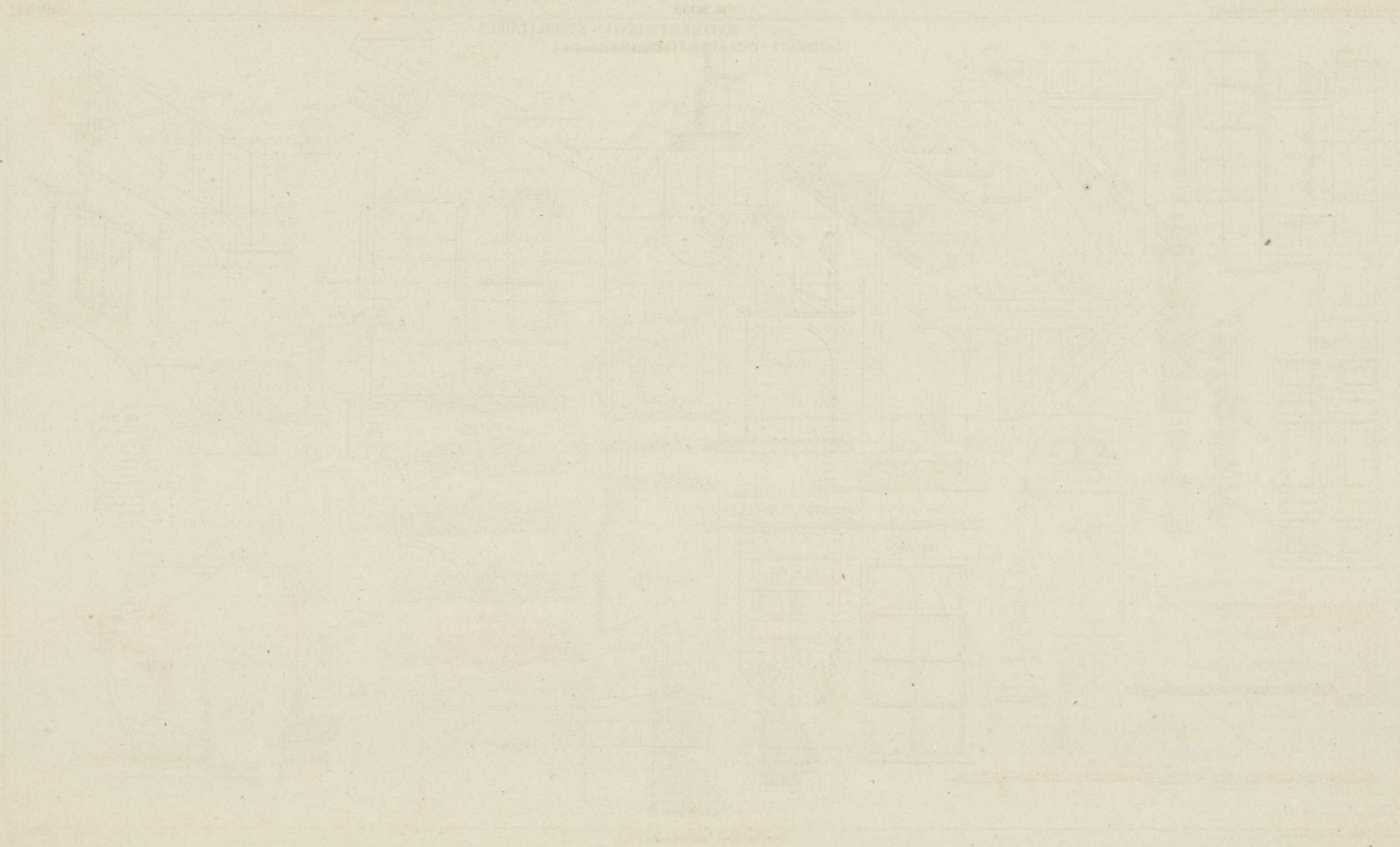
Additional architectural notes and specifications, including dimensions and material descriptions, located on the right side of the page.



PL. XLVIII.  
BATIMENTS CIVILS ET MILITAIRES.  
Combles, Escaliers.

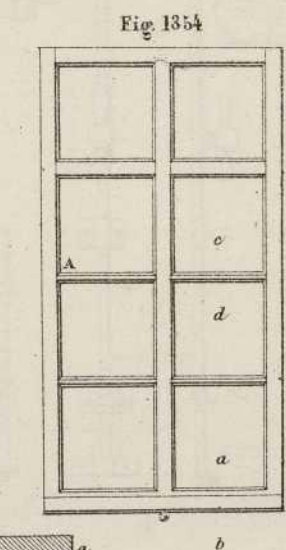
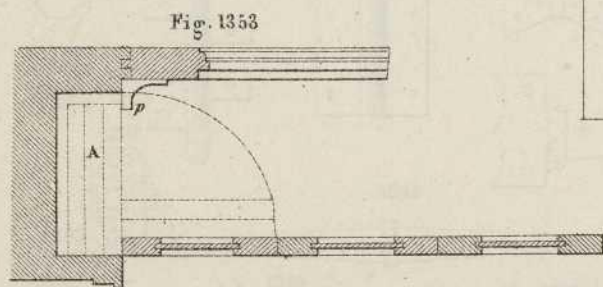
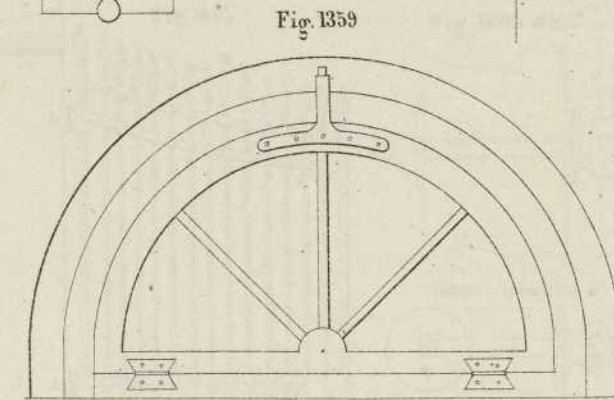
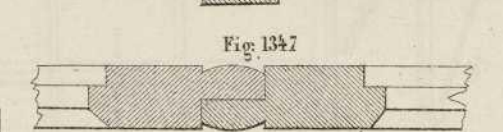
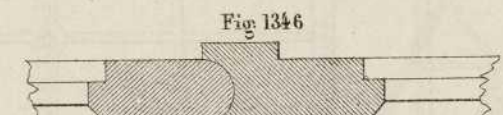
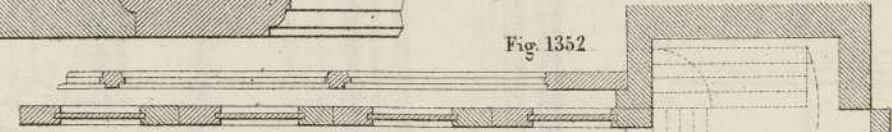
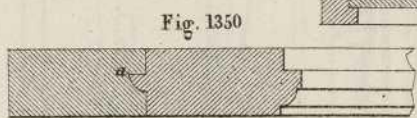
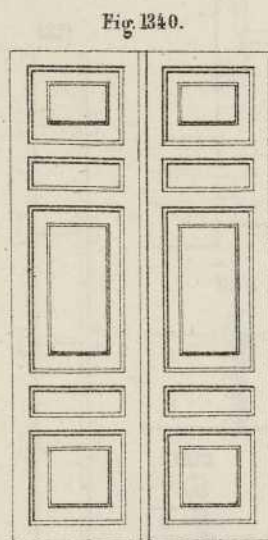
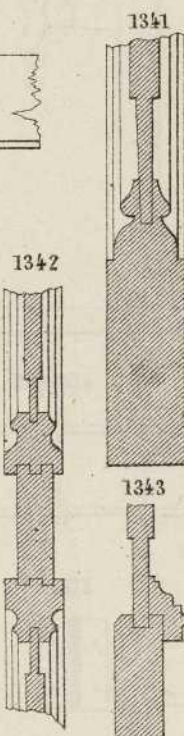
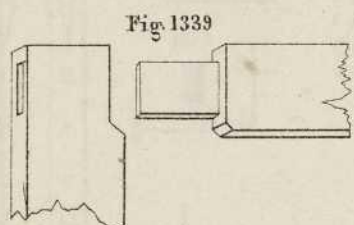
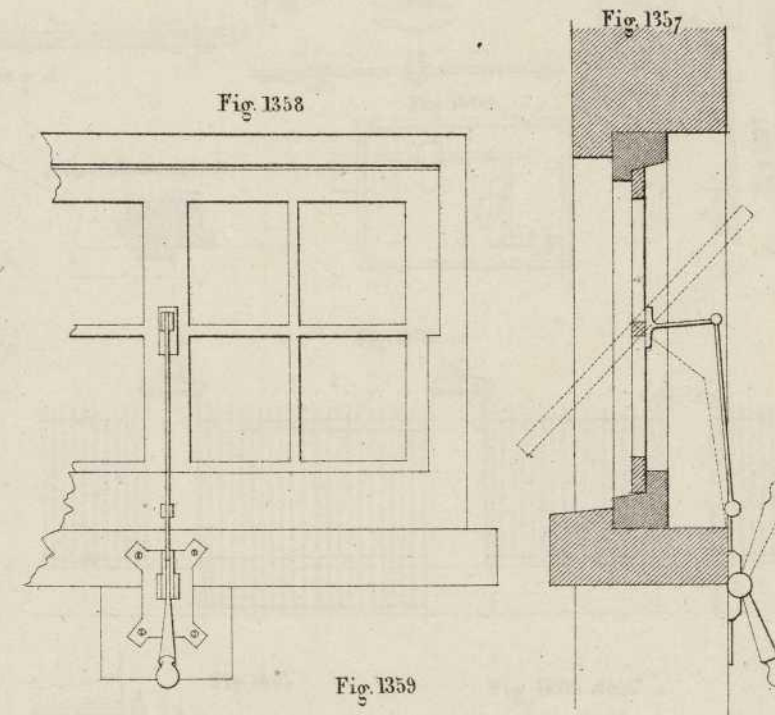
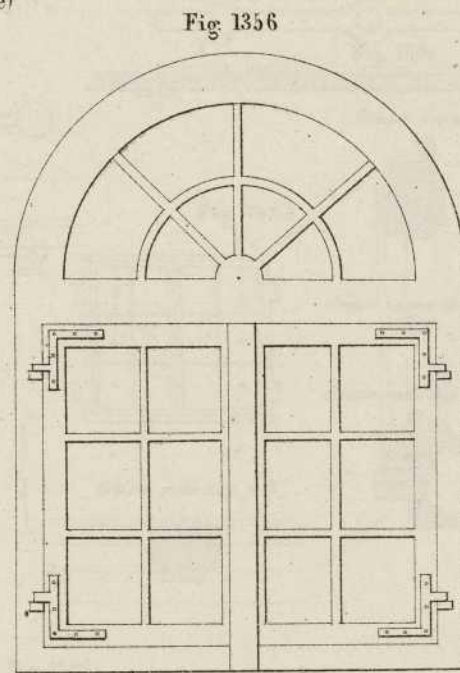
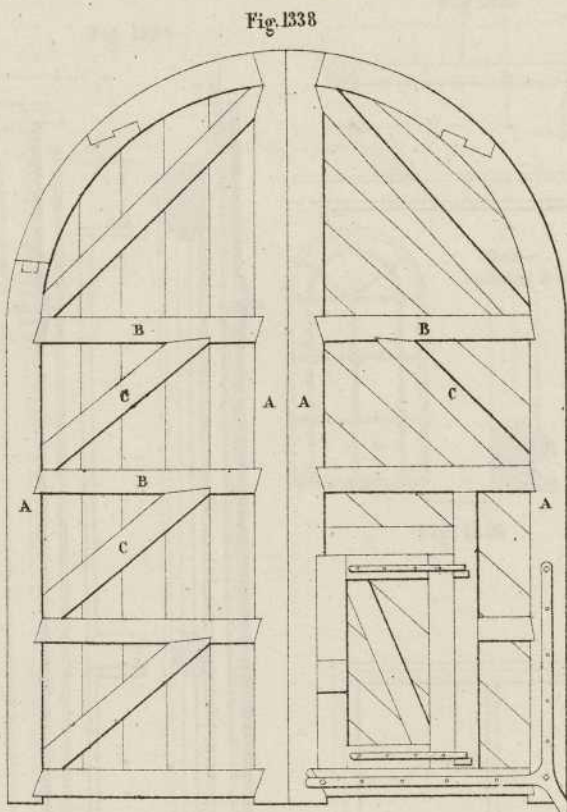
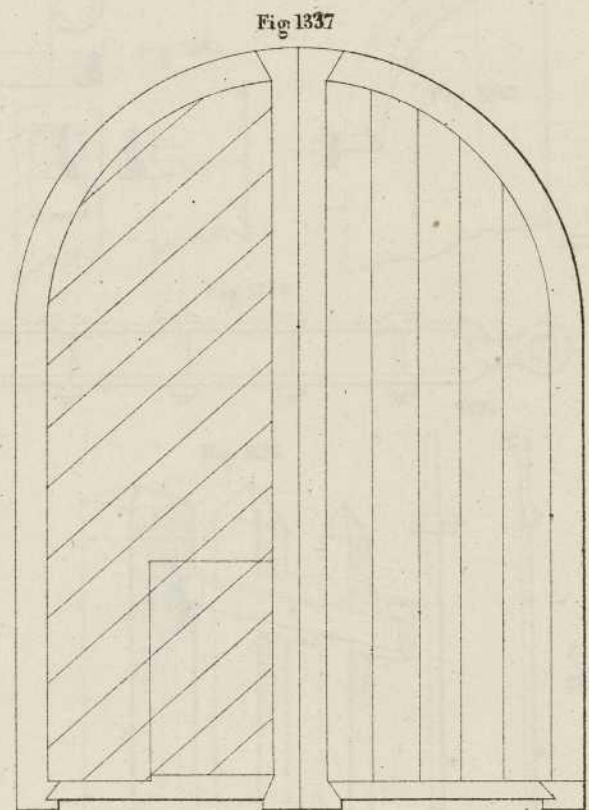
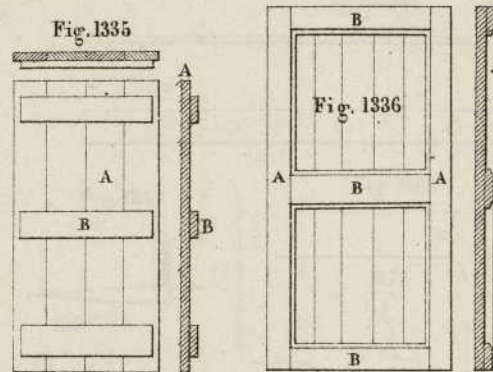




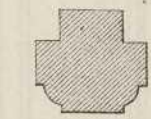




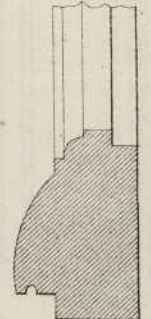
BATIMENTS CIVILS ET MILITAIRES (Menuiserie)



coupe suivant c d



coupe suivant a b



1355

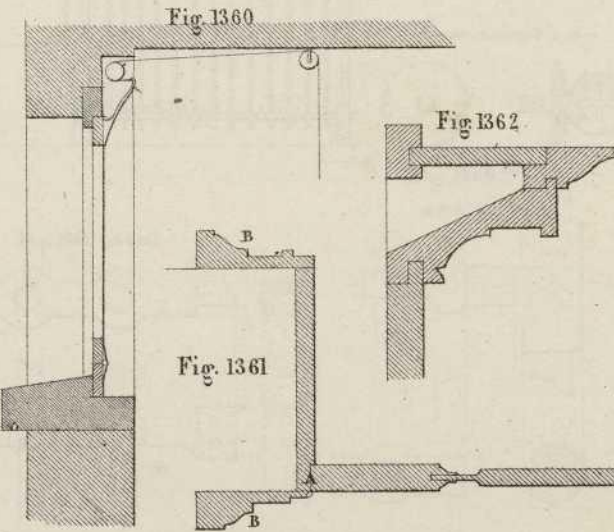
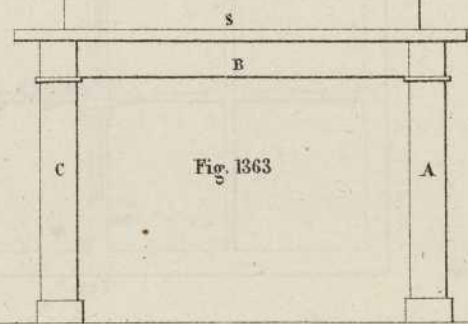
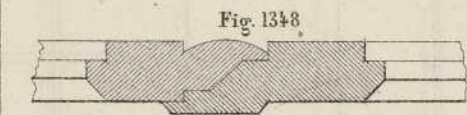
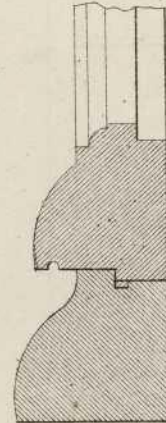
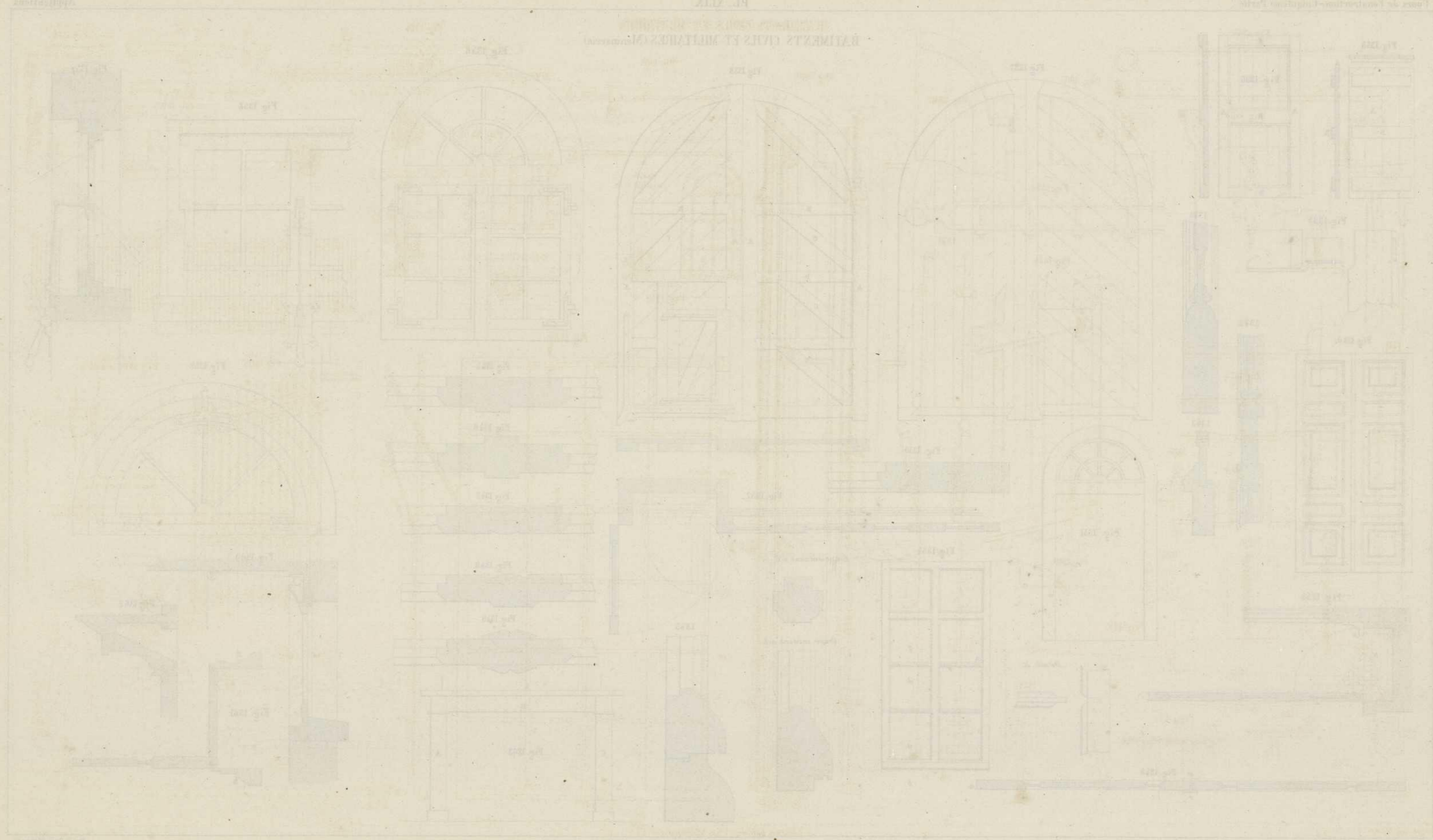


Fig. 1361

Fig. 1362

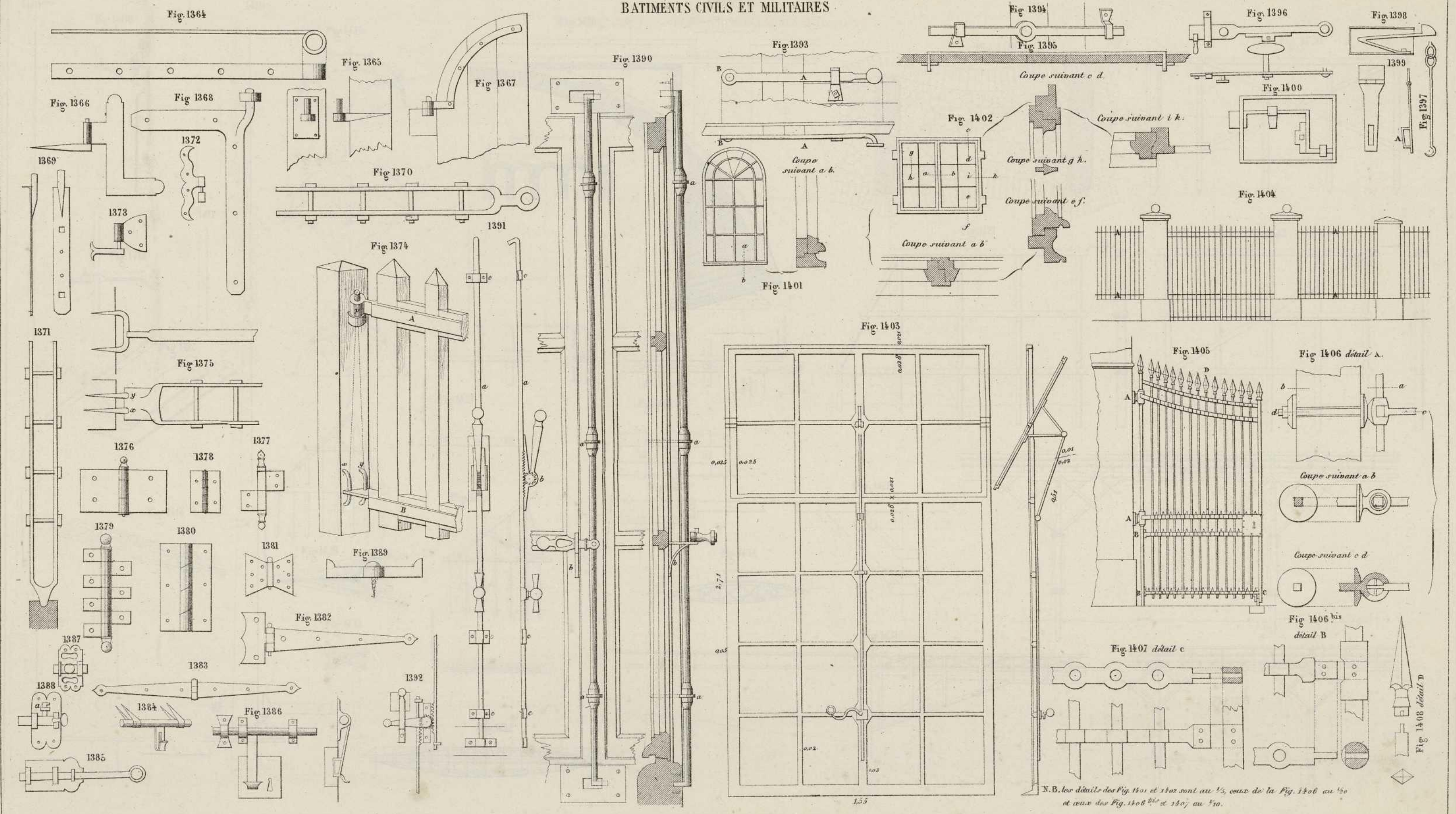


BATIMENTS CIVIS ET MILITAIRES (Continuation)





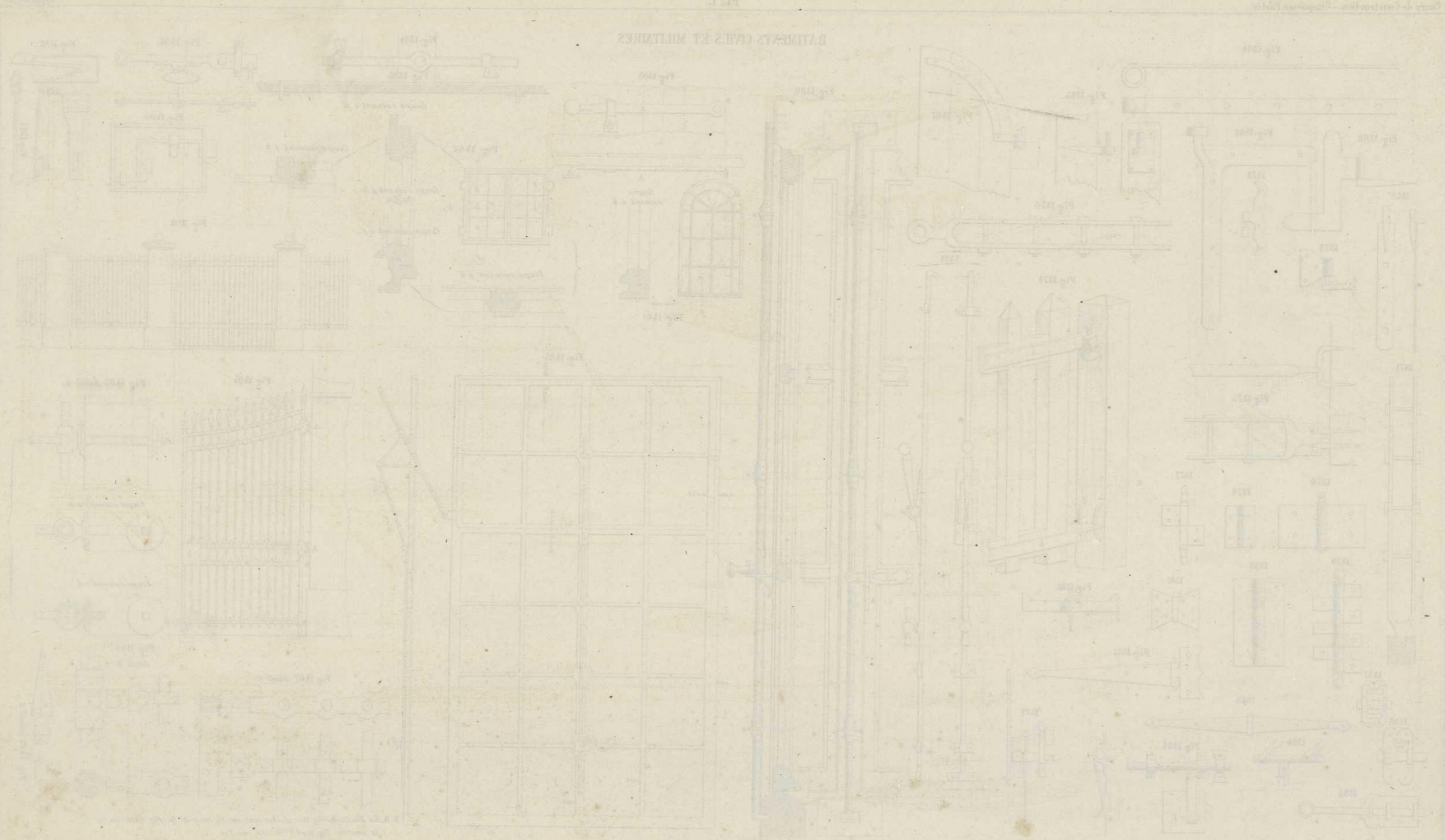
BATIMENTS CIVILS ET MILITAIRES



N.B. les détails des Fig. 1401 et 1402 sont au 1/5, ceux de la Fig. 1406 au 1/10 et ceux des Fig. 1406 bis et 1407 au 1/10.

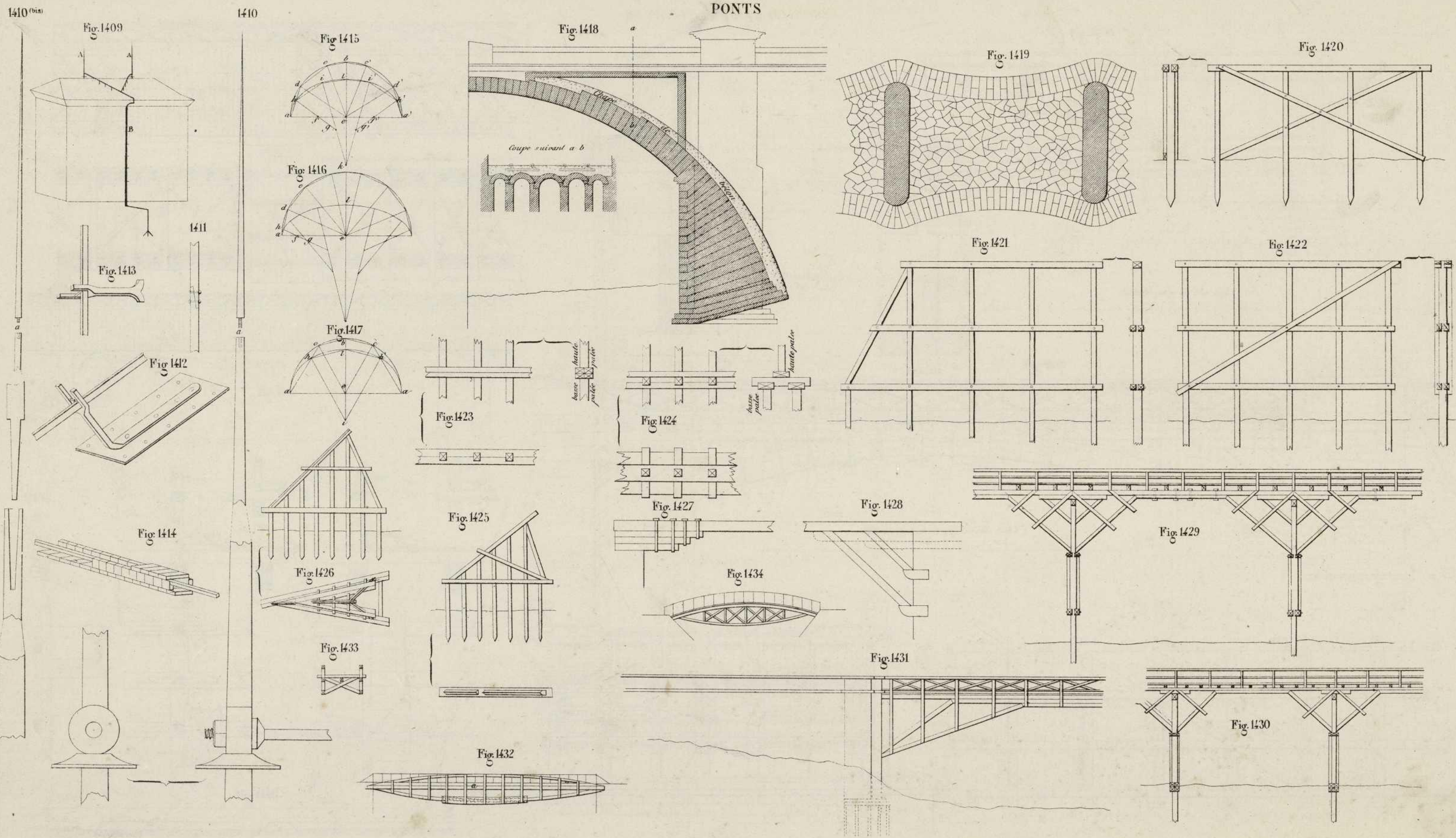


BATHINGS CIVILS ET MILITAIRES

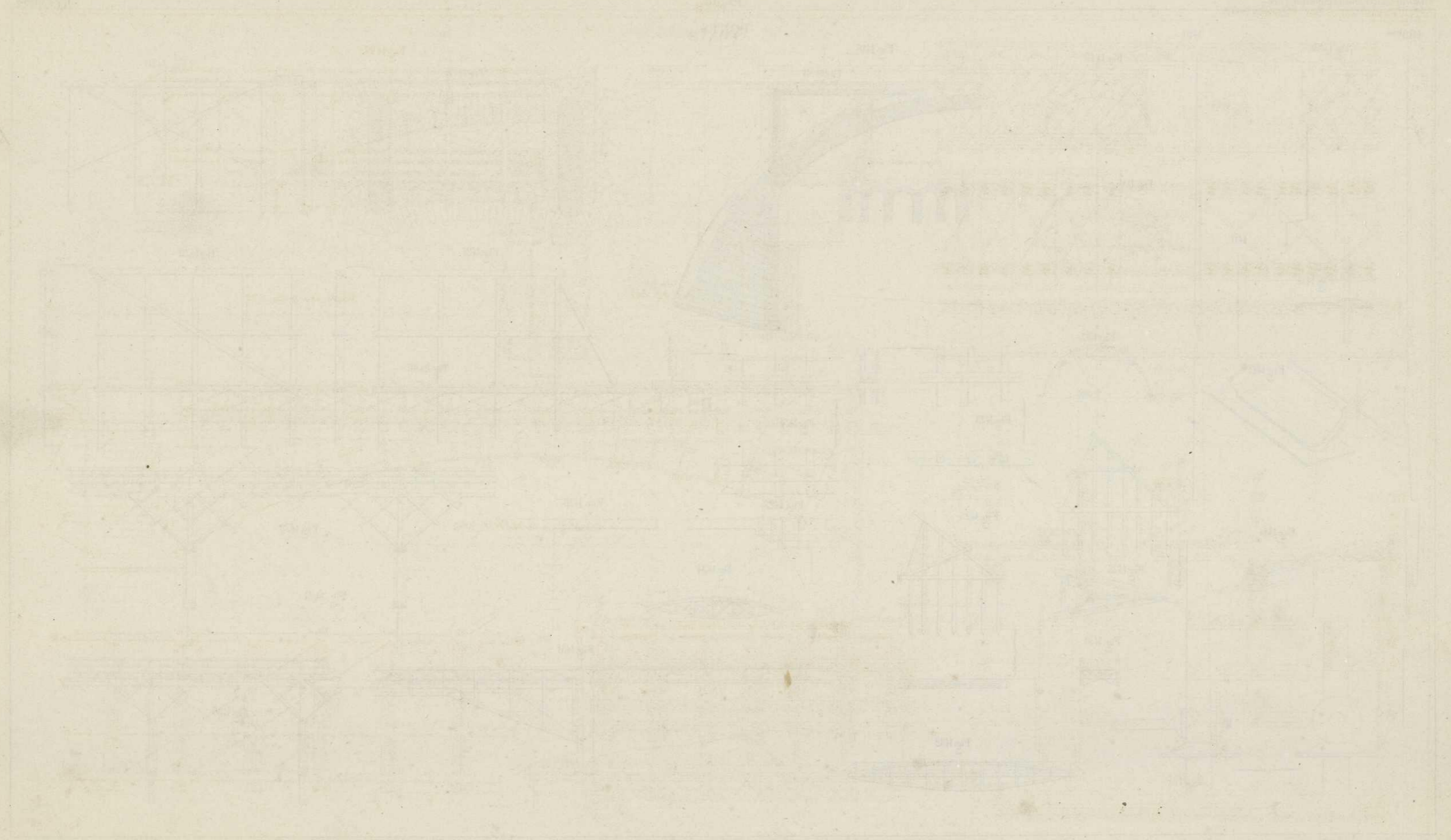




PONTS

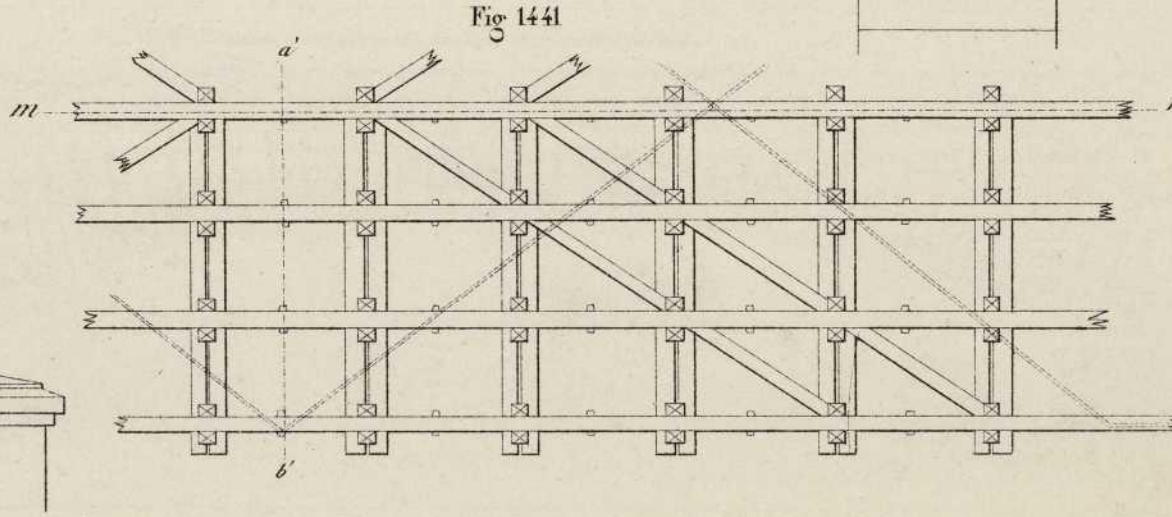
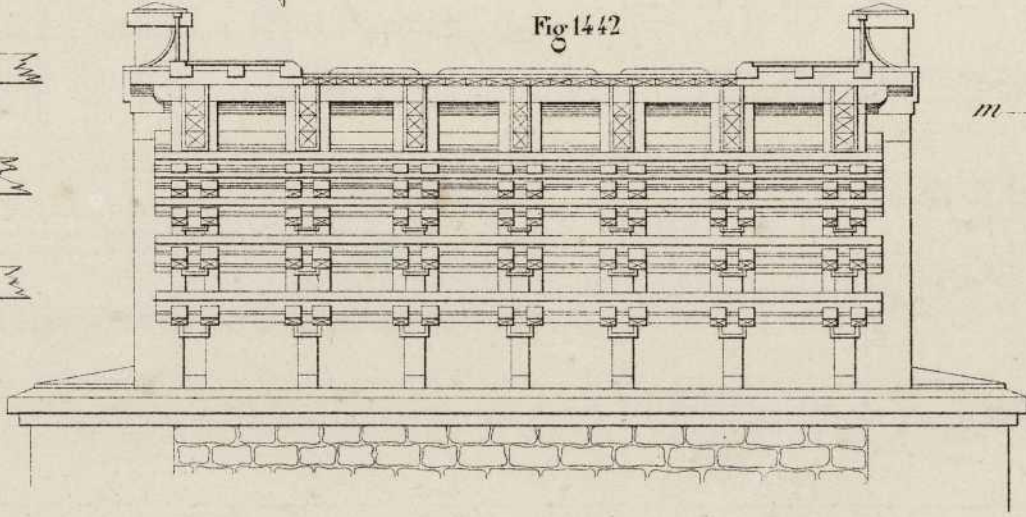
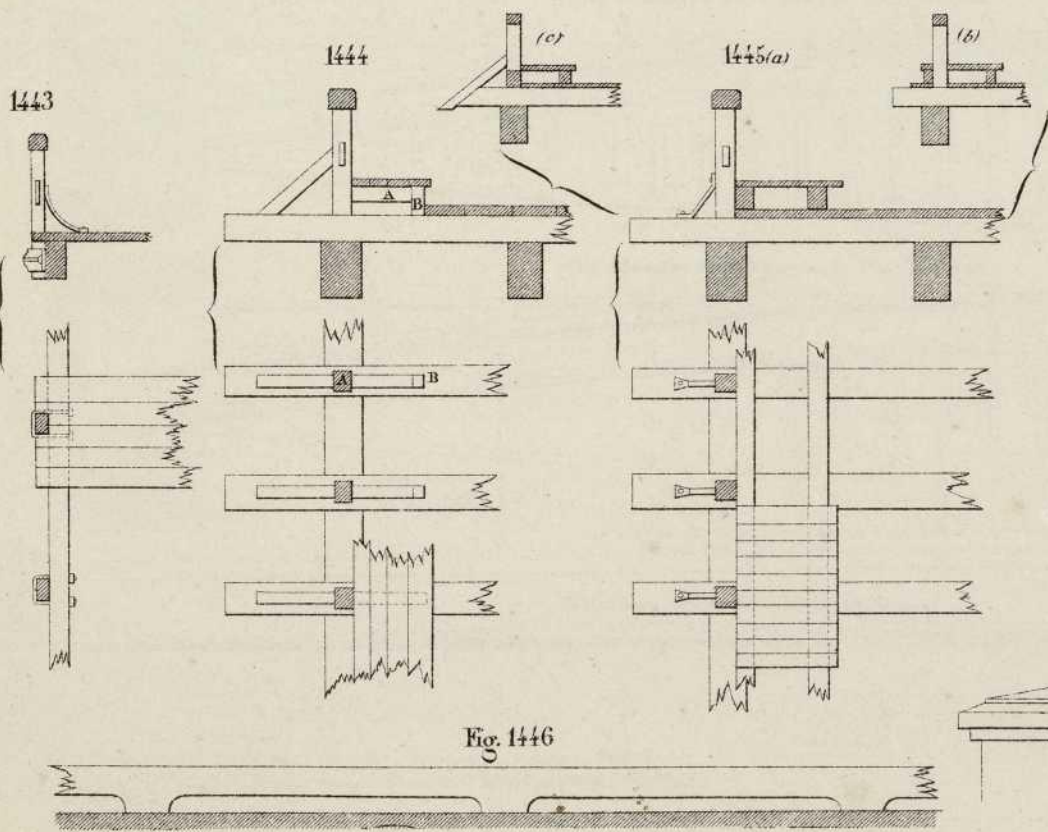
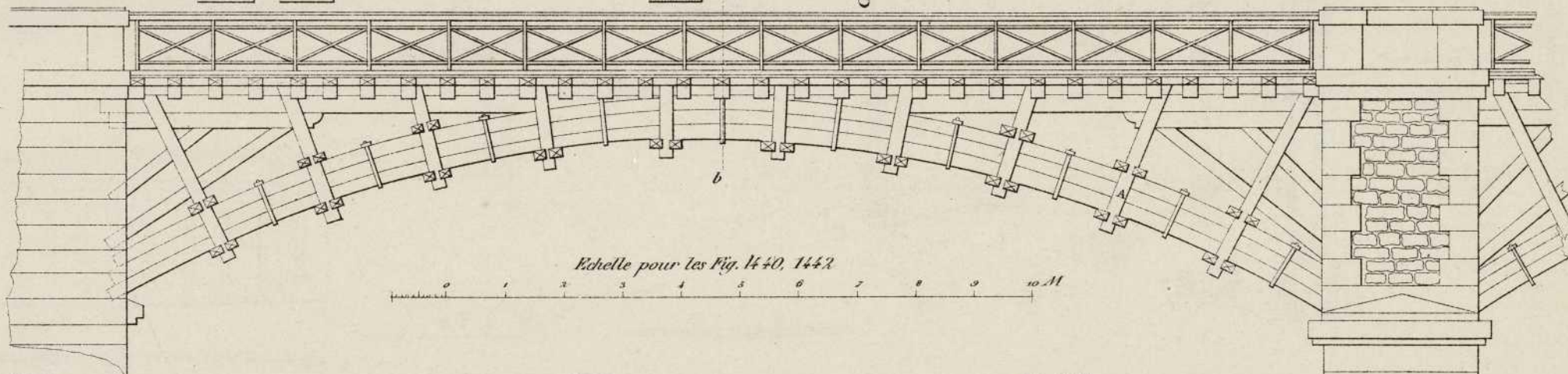
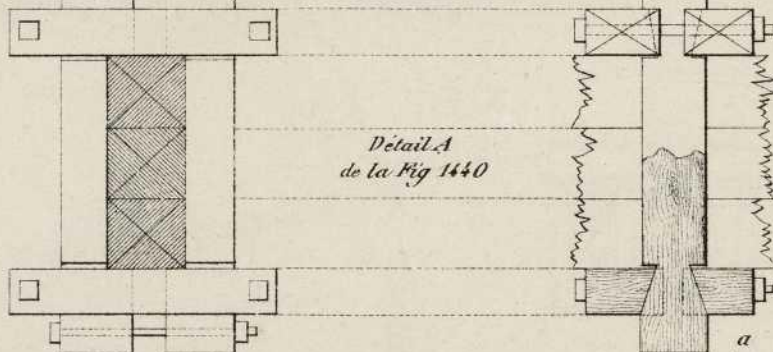
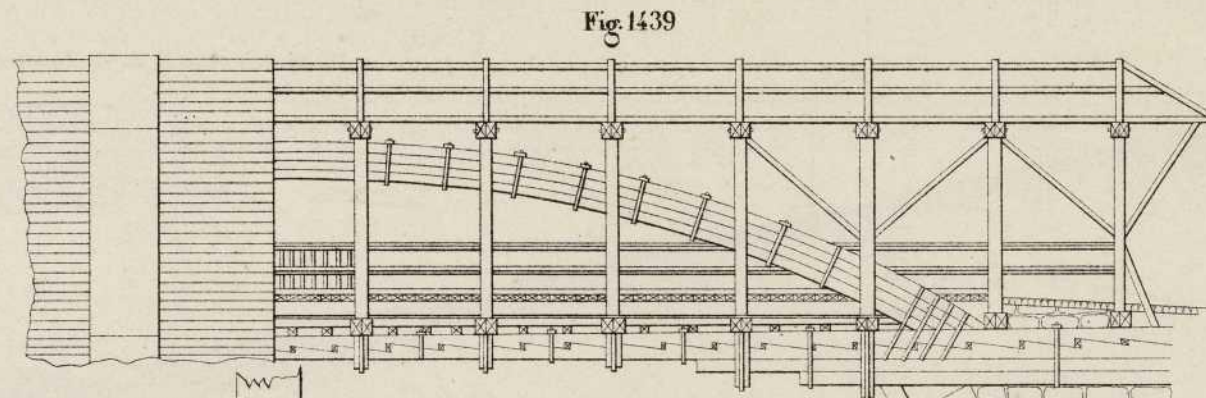
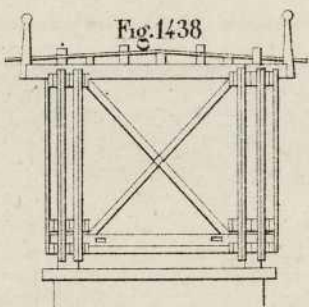
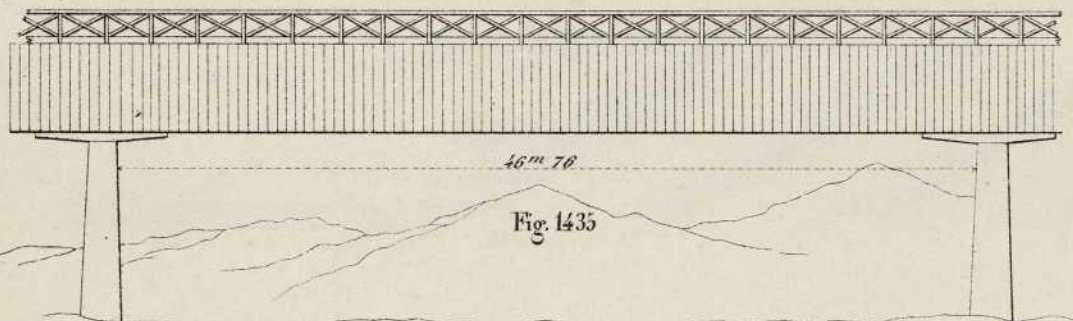
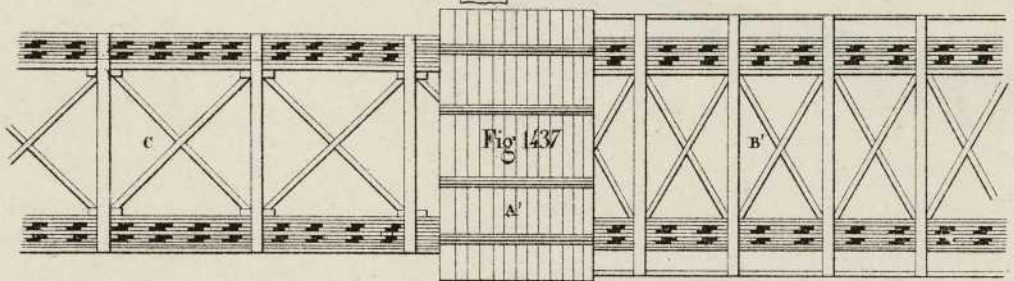
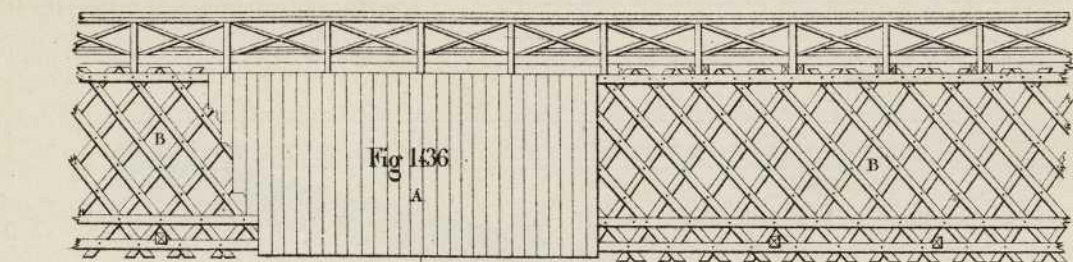




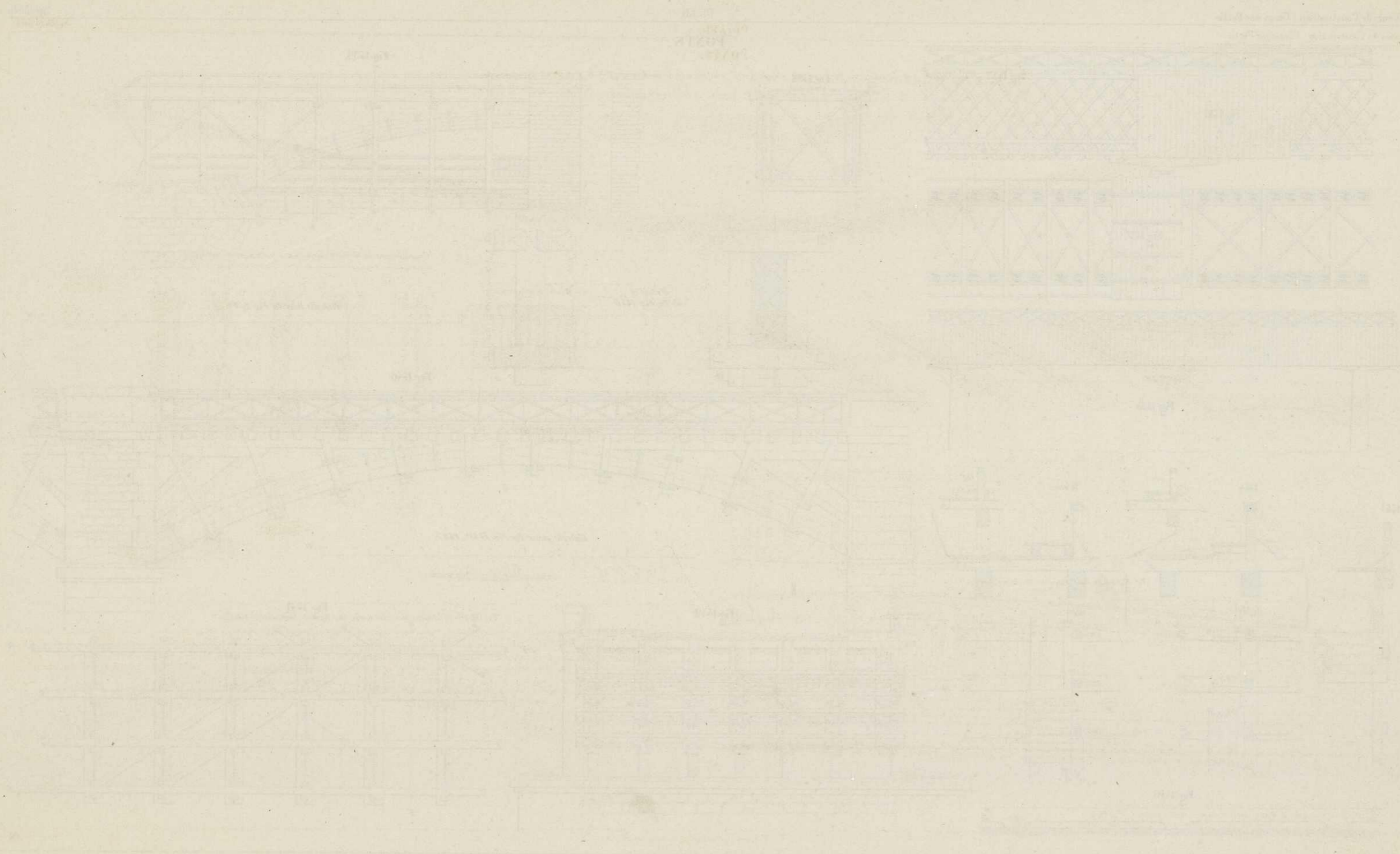




PONTS



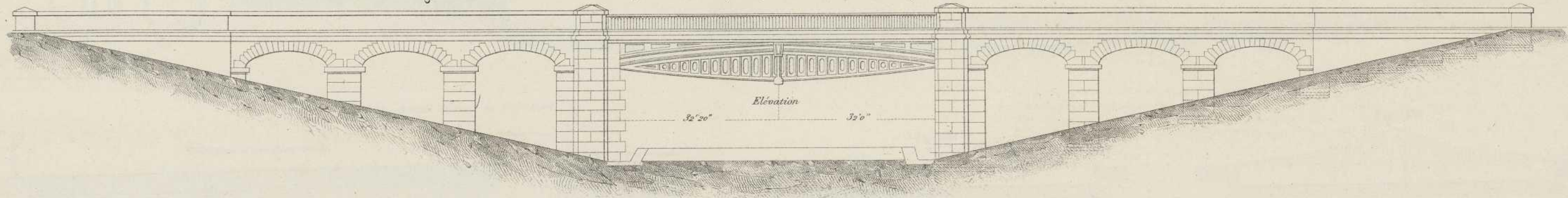




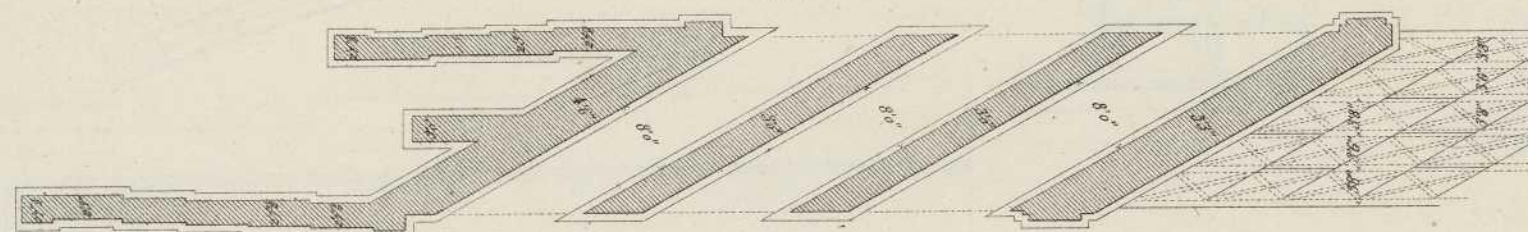


PONTS.

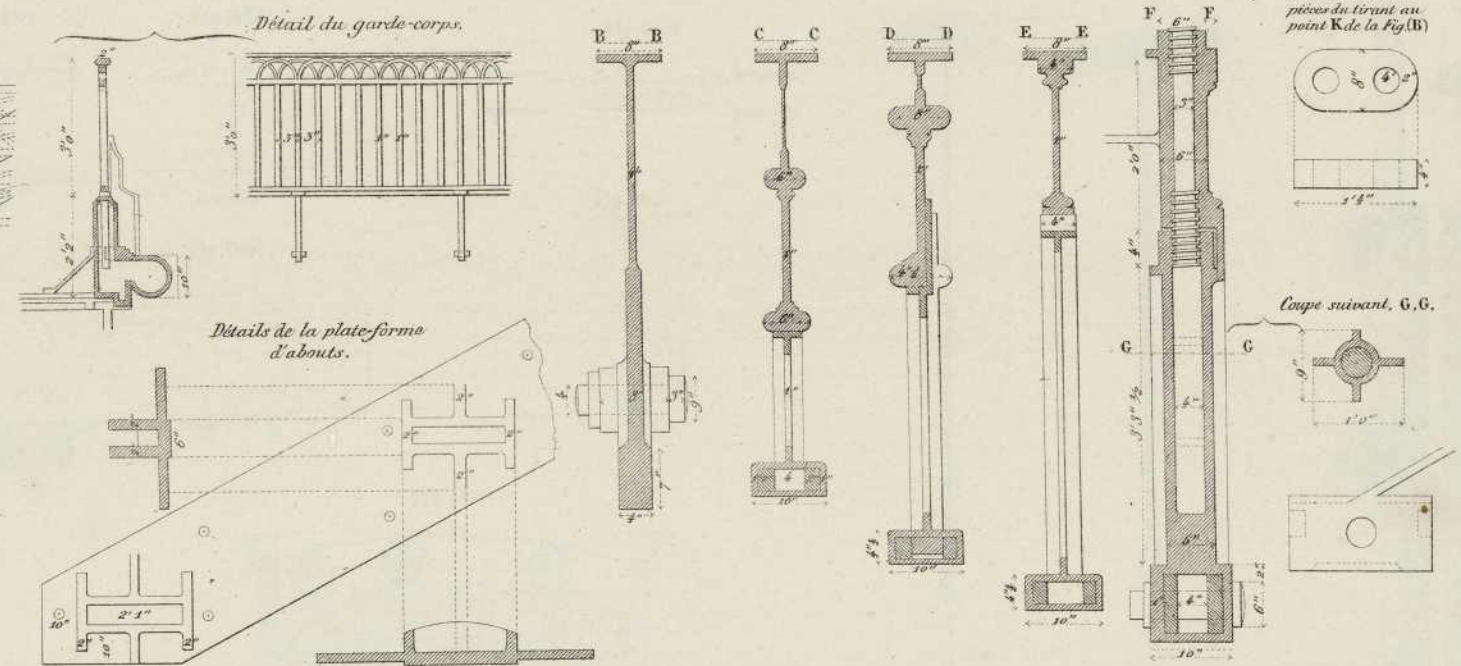
Fig. 1447 Plan, Elevation et détails d'un pont-viaduc oblique en fer établi sur le chemin de fer de Londres à Birmingham.



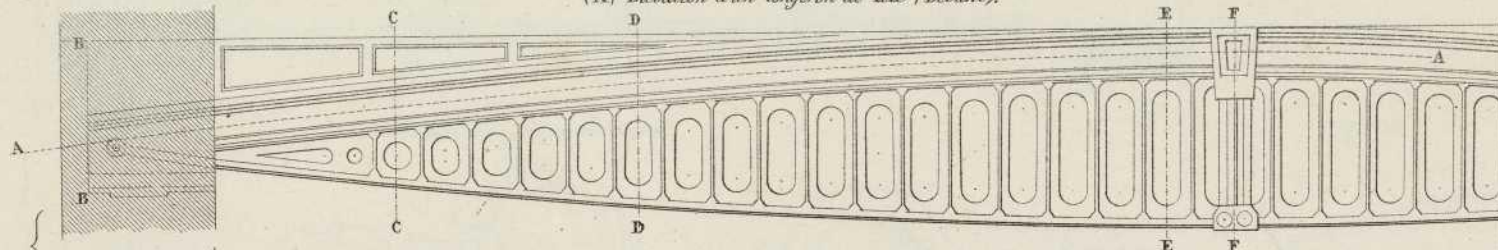
Plan.



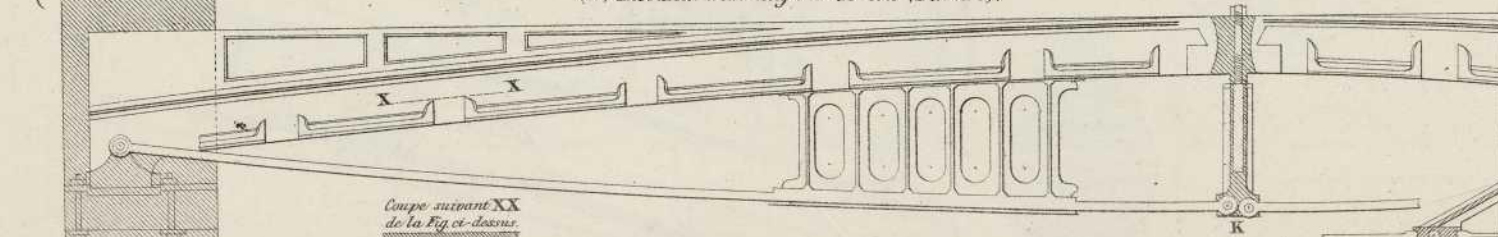
Coupes transversales des longerons sur les lignes de la Figure (A).



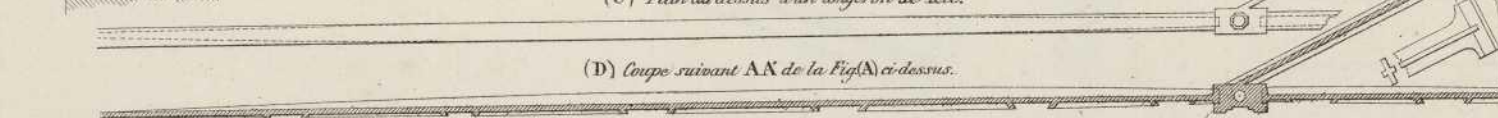
(A) Elevation d'un longeron de tête (Devant).



(B) Elevation d'un longeron de tête (Derrière).



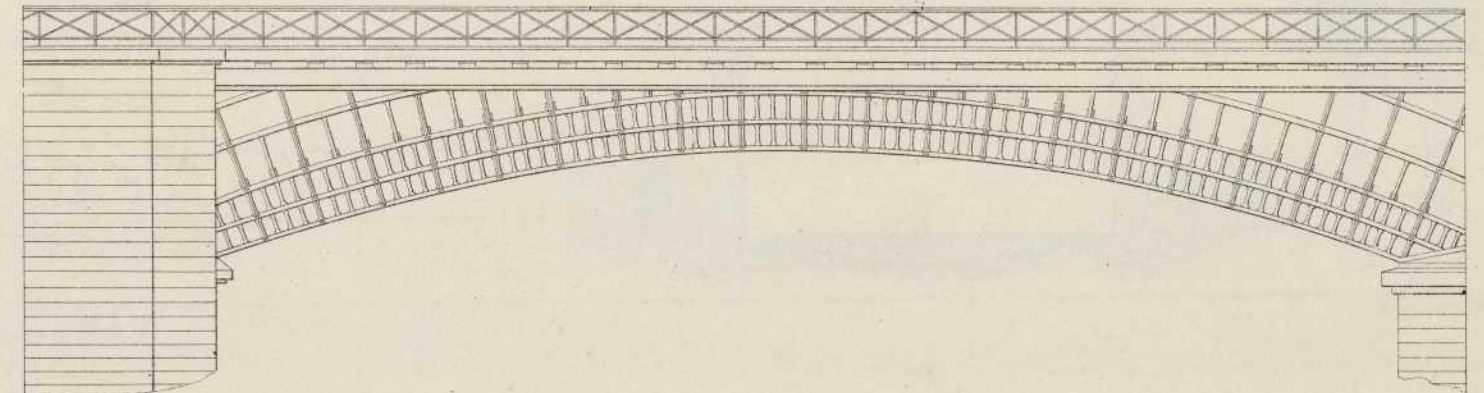
(C) Plan de dessus d'un longeron de tête.



(D) Coupe suivant AK de la Fig(A) et dessus.

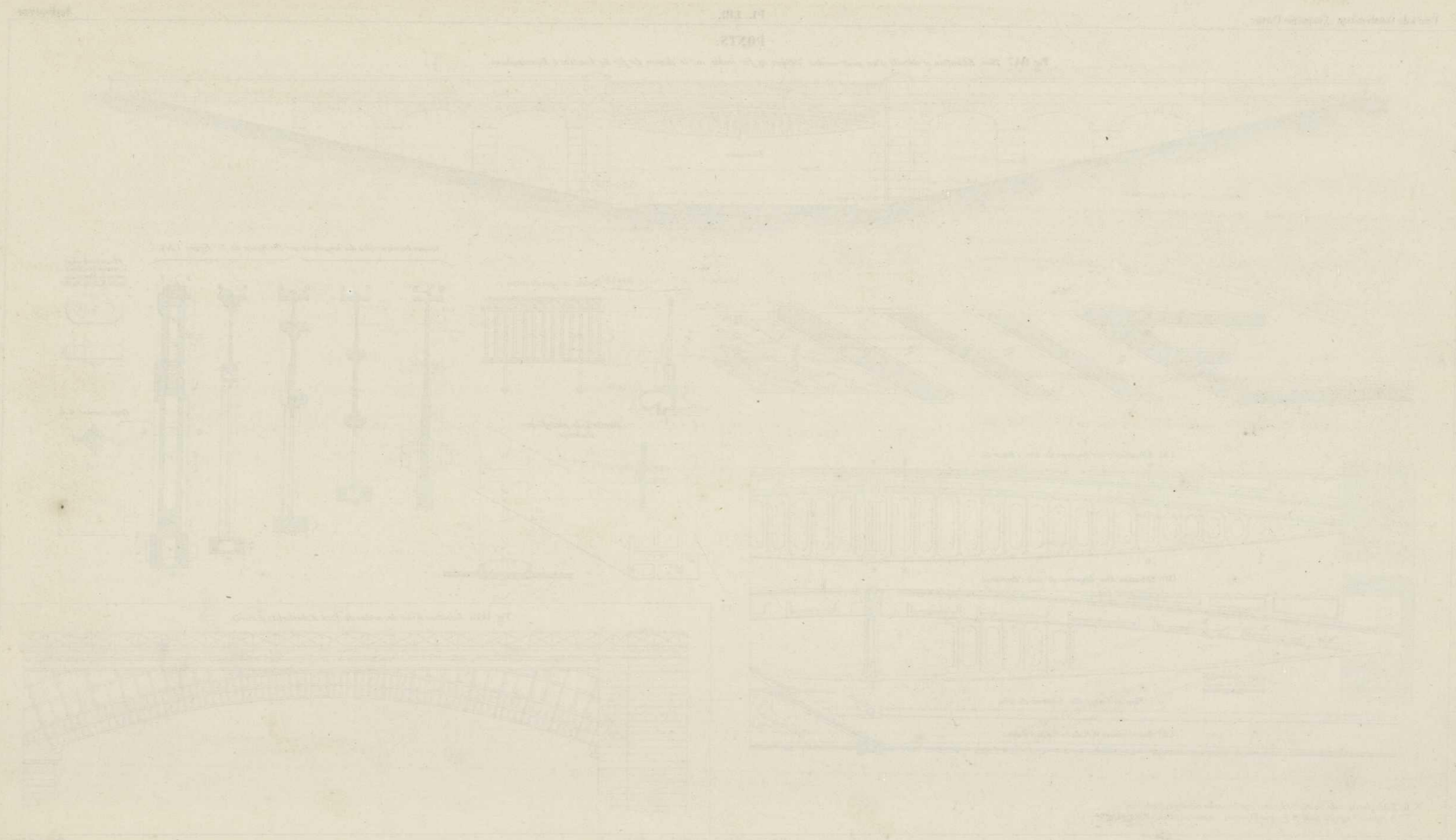


Fig. 1448 Elevation d'une des arches du Pont d'Austerlitz à Paris.



N. B. Toutes les cotes de la Fig. 1447 sont exprimées en mesures Anglaises. le signe (") signifie pied et le signe (') pouce. - le pied anglais = 0<sup>m</sup>.304797.







PONTS.

Elevation du pont du Carroussel construit à Paris par Polonceau.

Fig. 1450

Fig. 1449

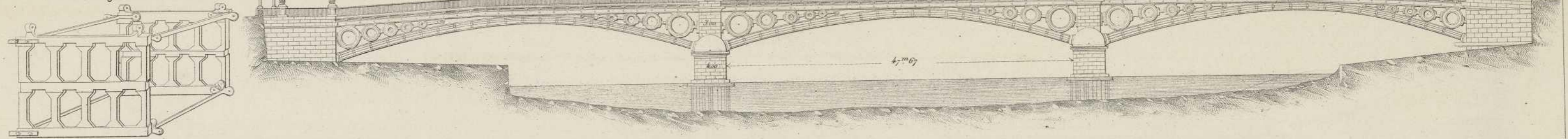
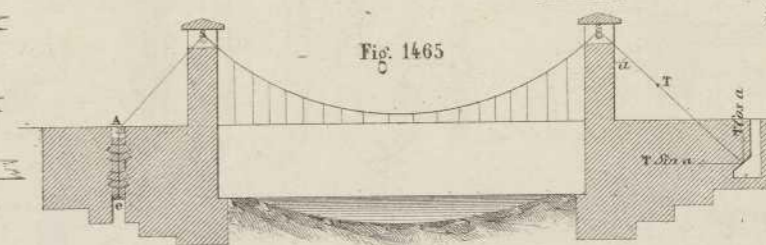
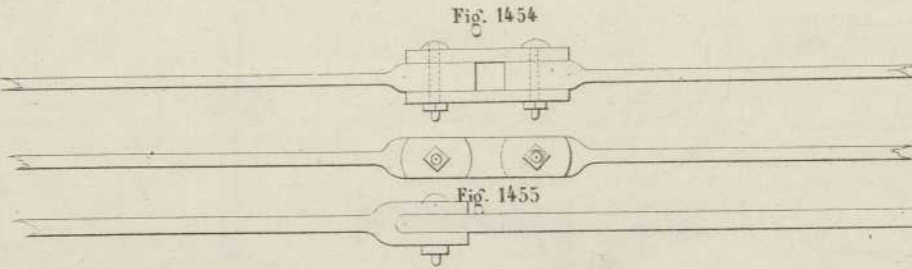
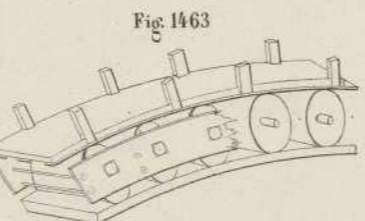
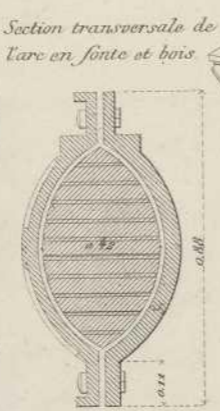
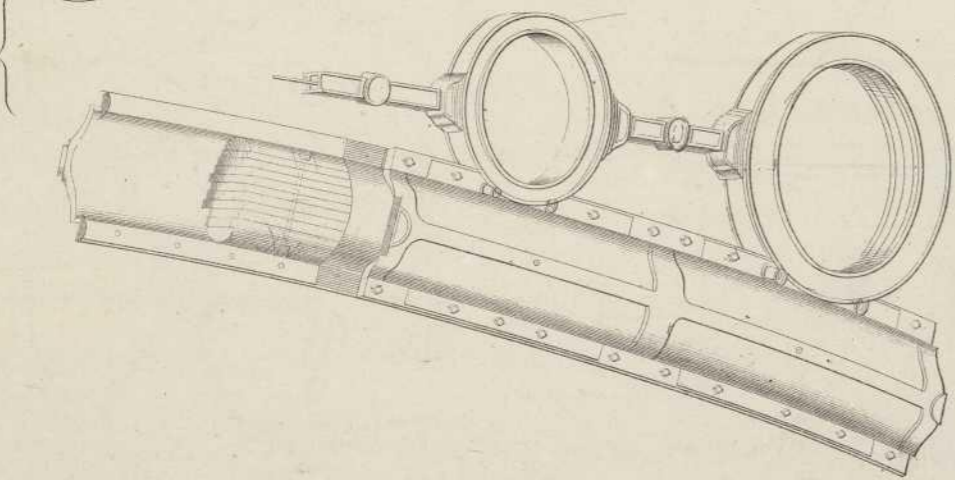
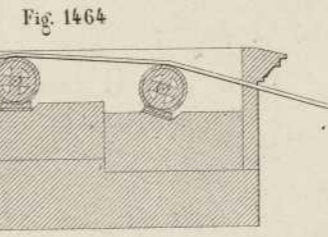
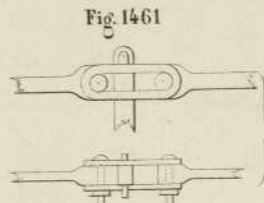
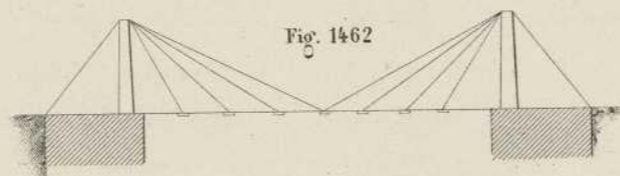
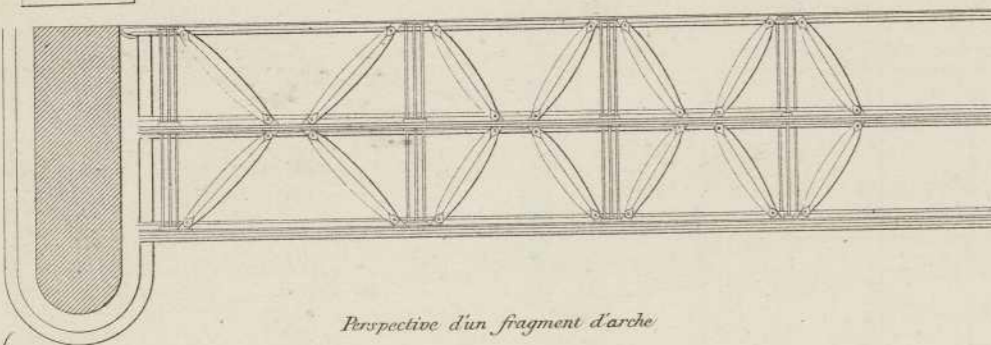
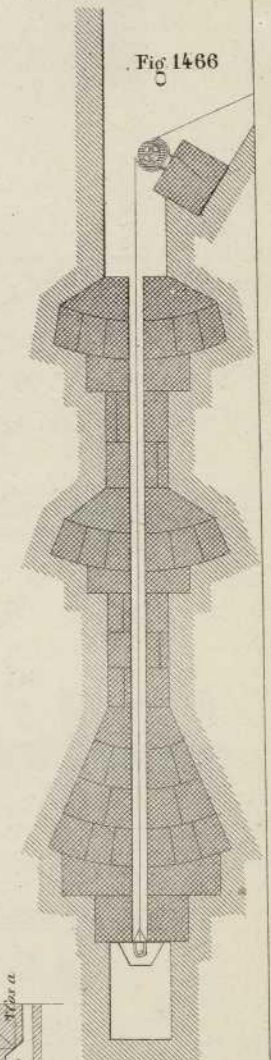
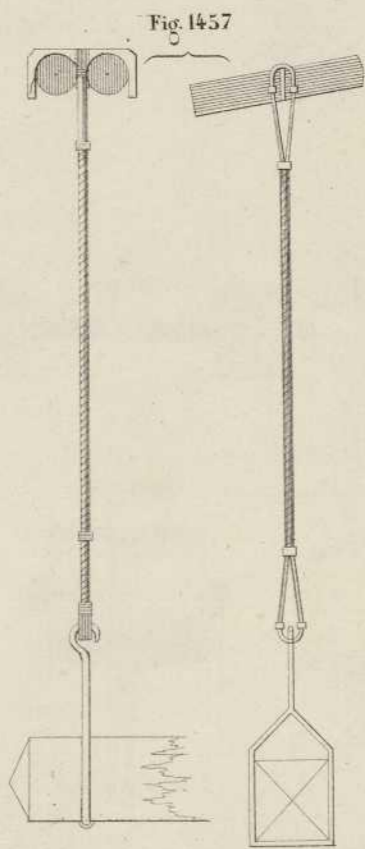
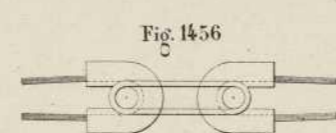
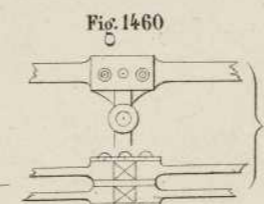
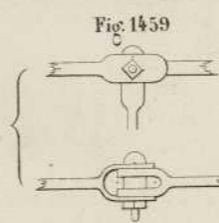
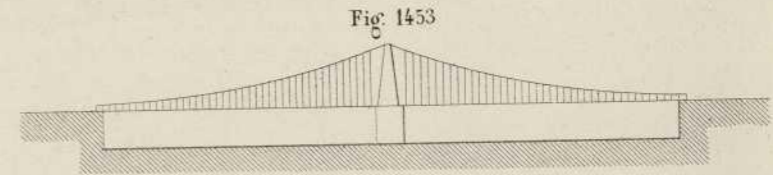
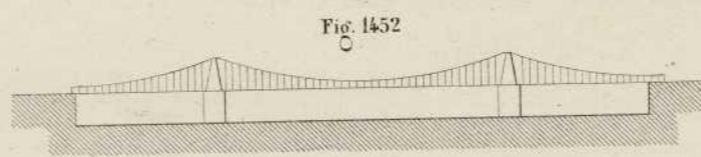
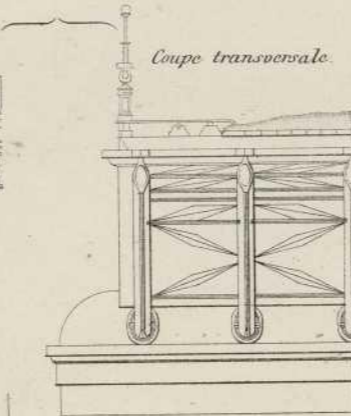
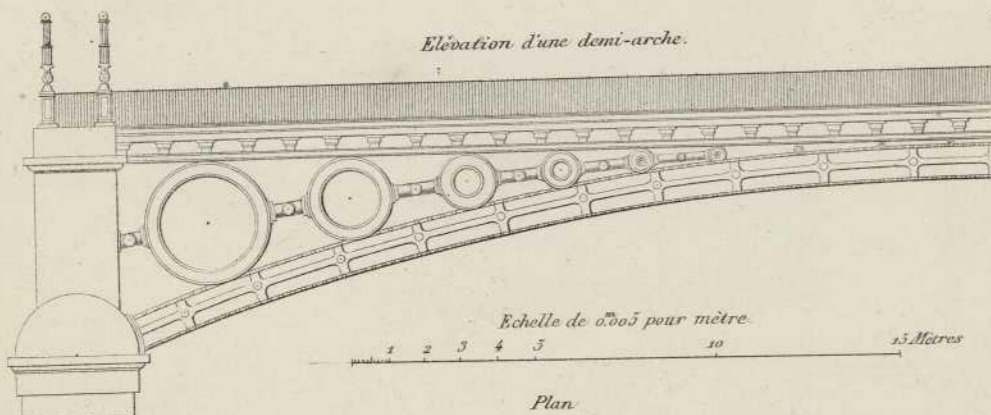
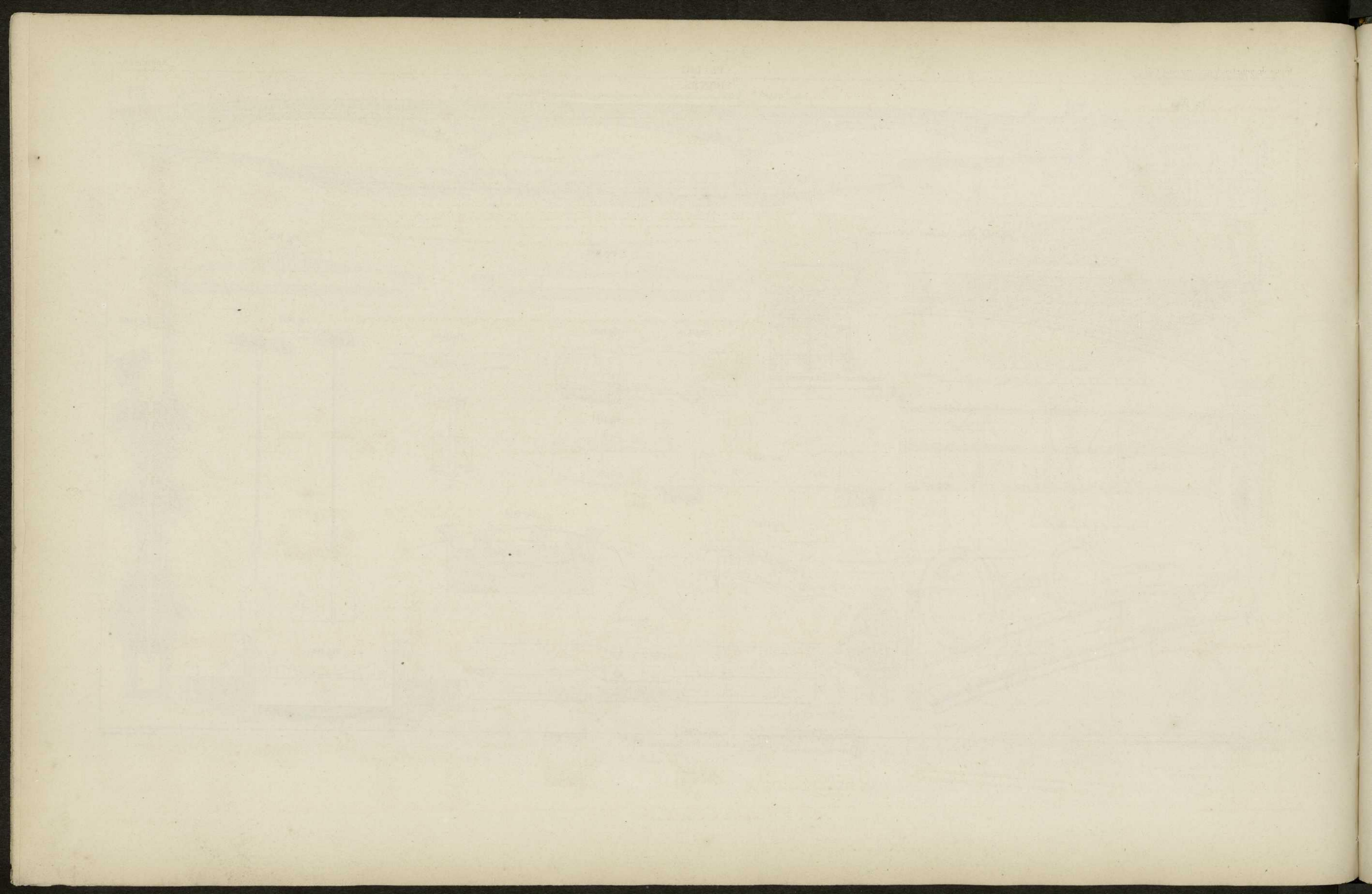


Fig. 1451. Détails du pont du Carroussel.

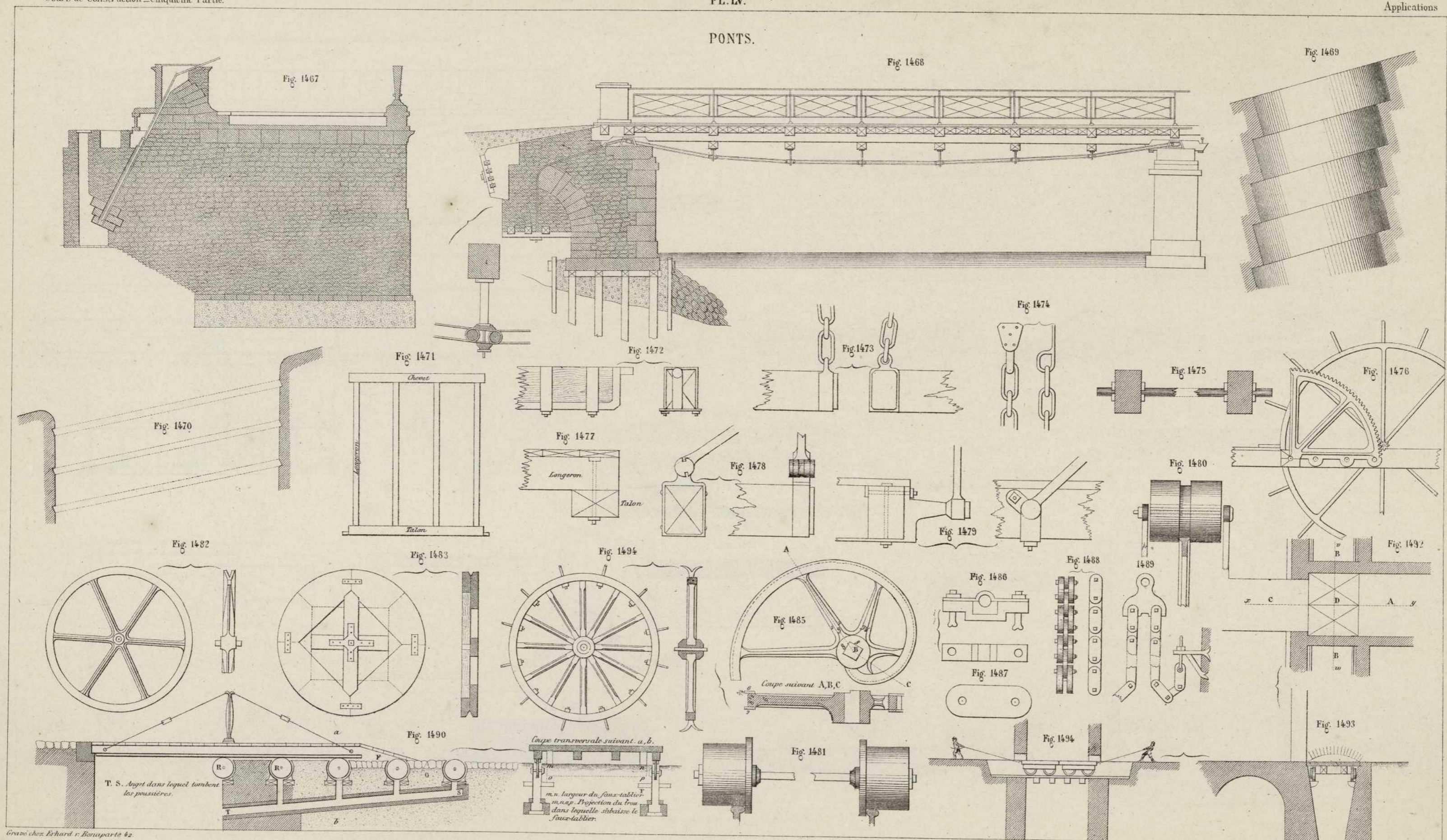






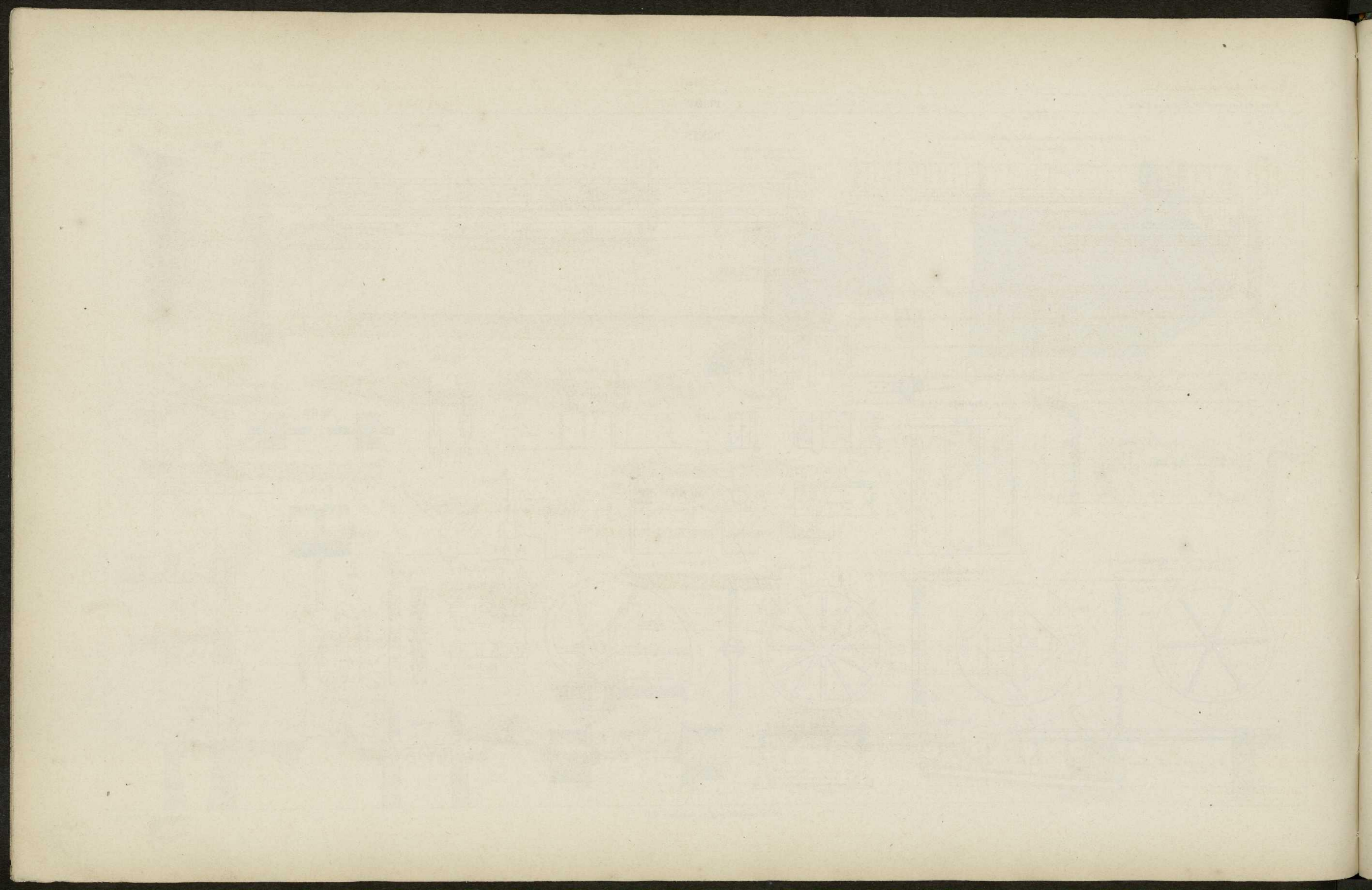


PONTS.



Gravé chez Erhard & Bonaparte 42.

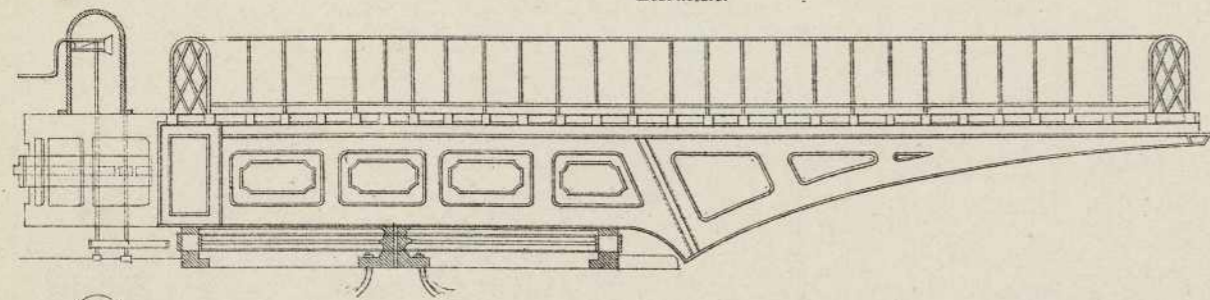




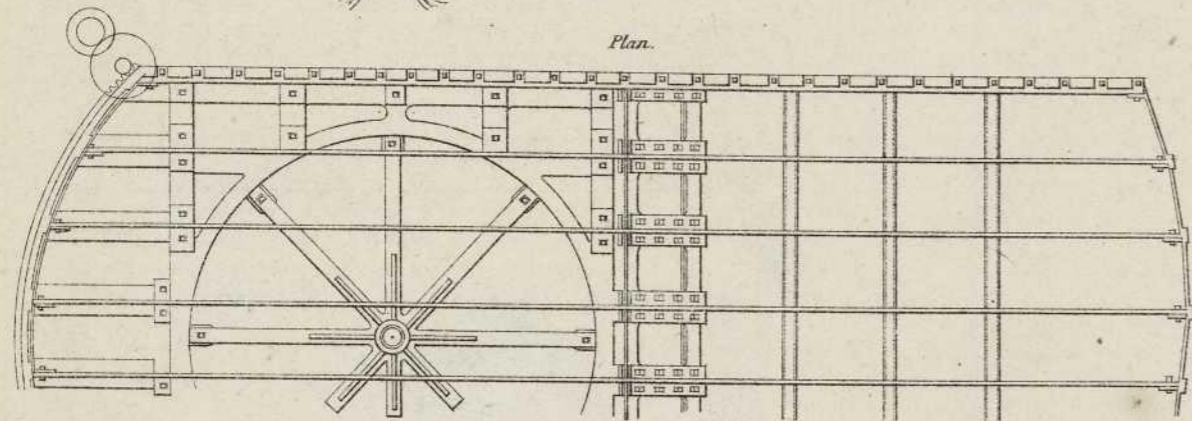


PONTS.

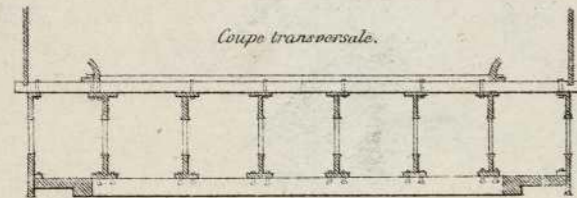
Fig. 1491. Plan, Elevation, Coupe et details d'un pont tournant.  
Elevation.



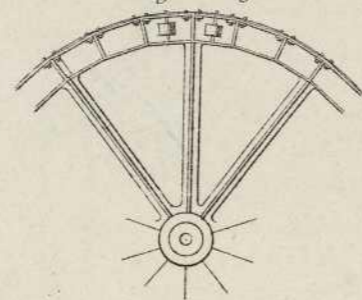
Plan.



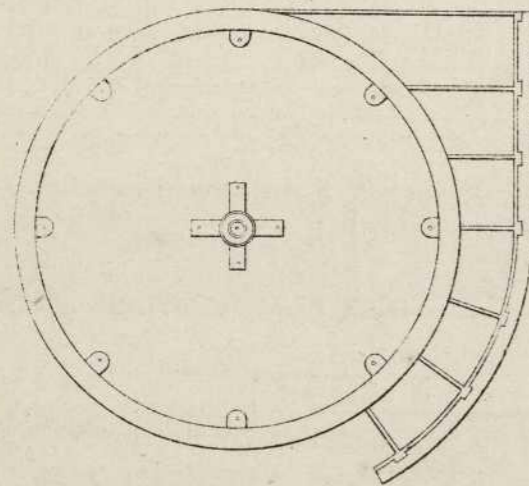
Coupe transversale.



Chariot et galets de friction.



Plan du pivot et de la plaque circulaire sur laquelle roulent les galets de friction.



Plan de la plaque circulaire placee au dessus des galets de friction.

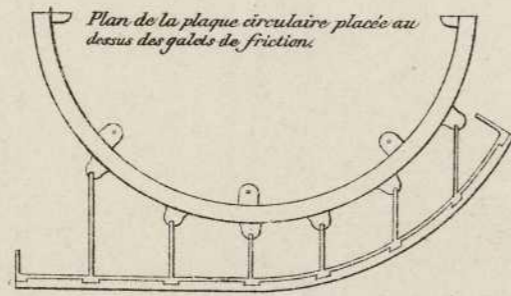
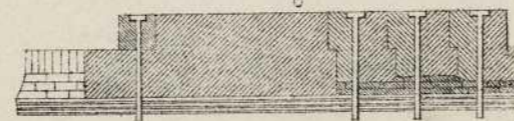


Fig. 1504



Engrenage servant à manœuvrer le pont.

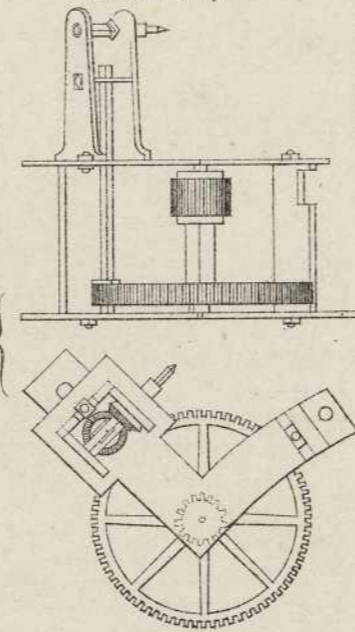


Fig. 1499

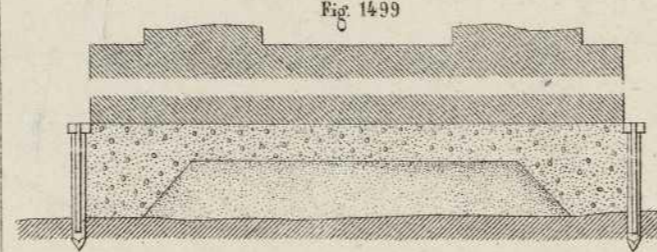


Fig. 1502

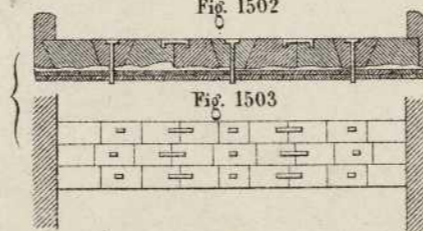


Fig. 1503

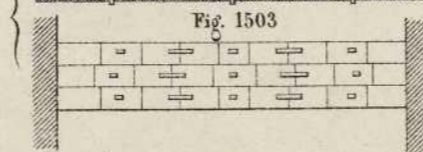


Fig. 1506

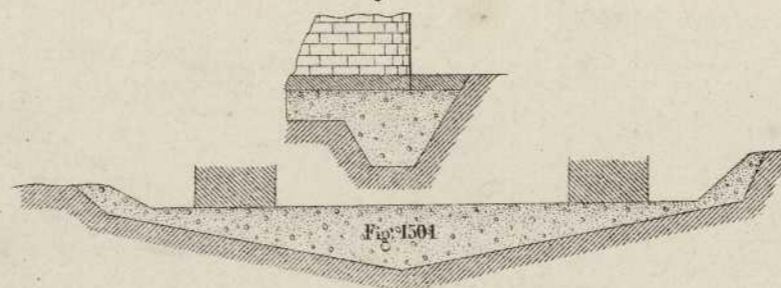


Fig. 1501

ÉCLUSES.

Fig. 1495

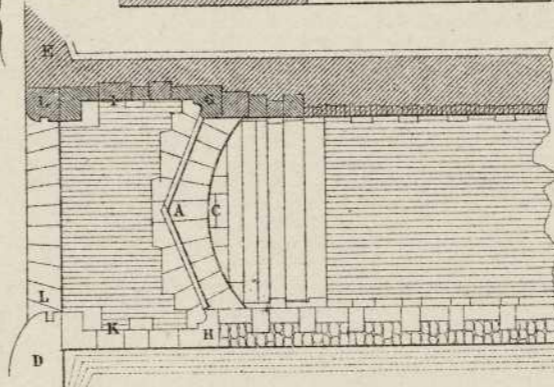
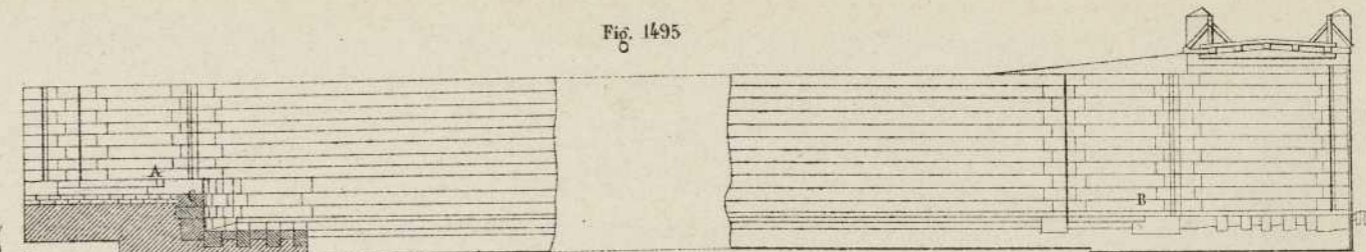


Fig. 1496

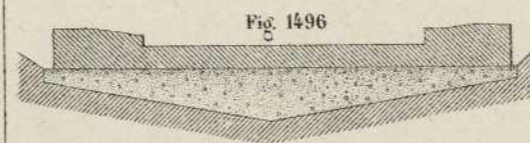


Fig. 1497

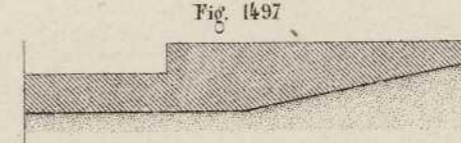


Fig. 1498

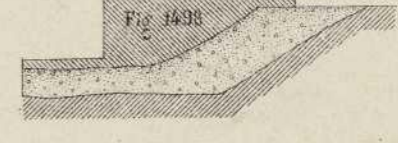


Fig. 1505

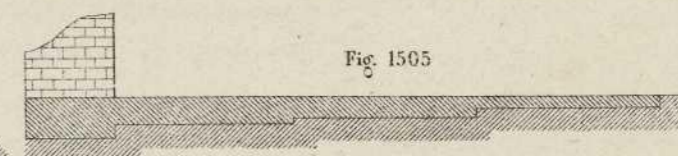


Fig. 1500

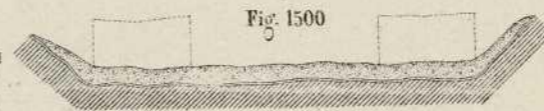


Fig. 1509

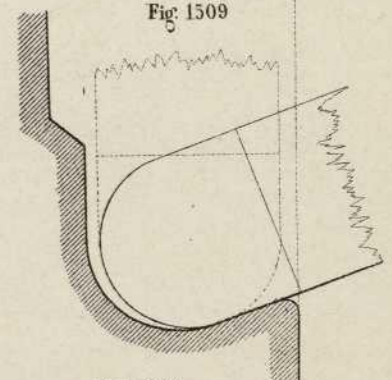


Fig. 1511

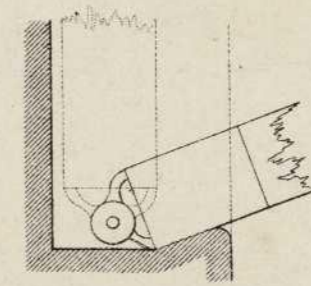


Fig. 1508

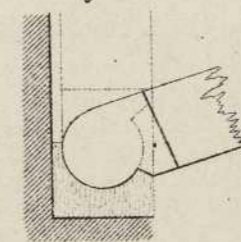
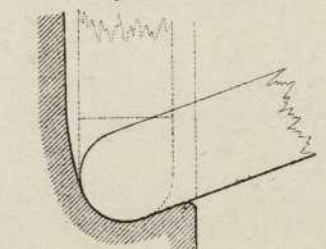
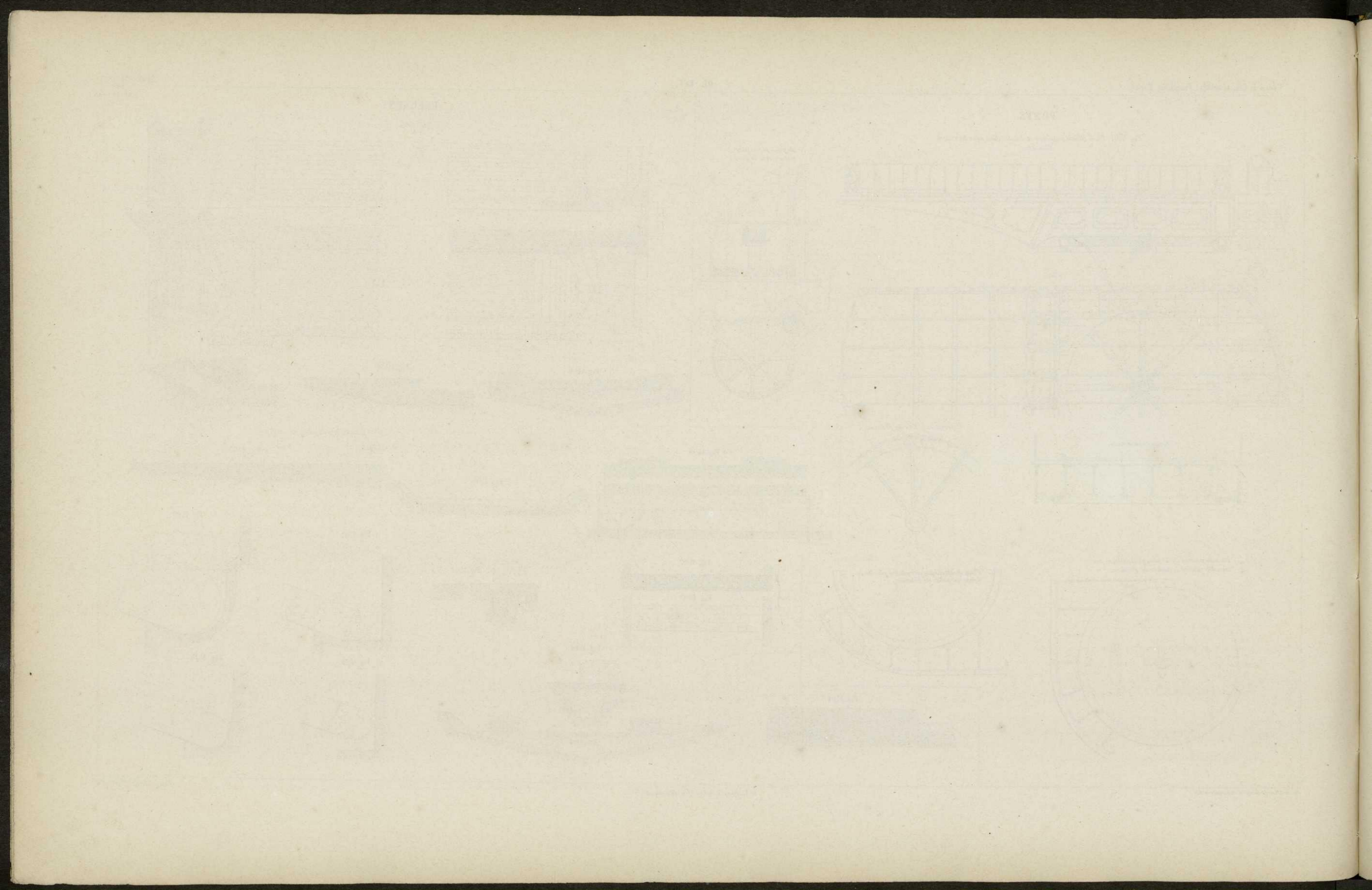


Fig. 1510

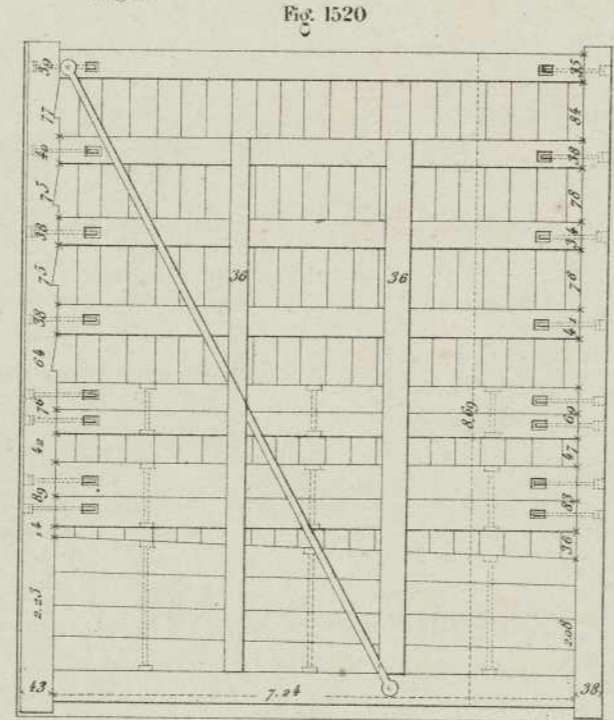
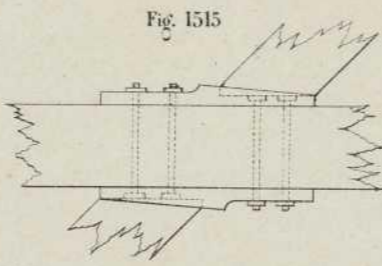
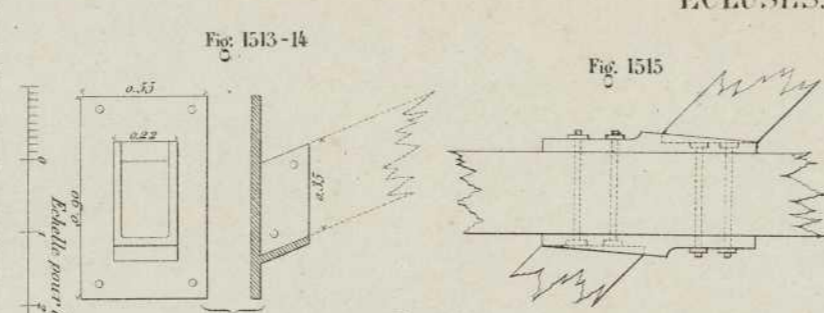
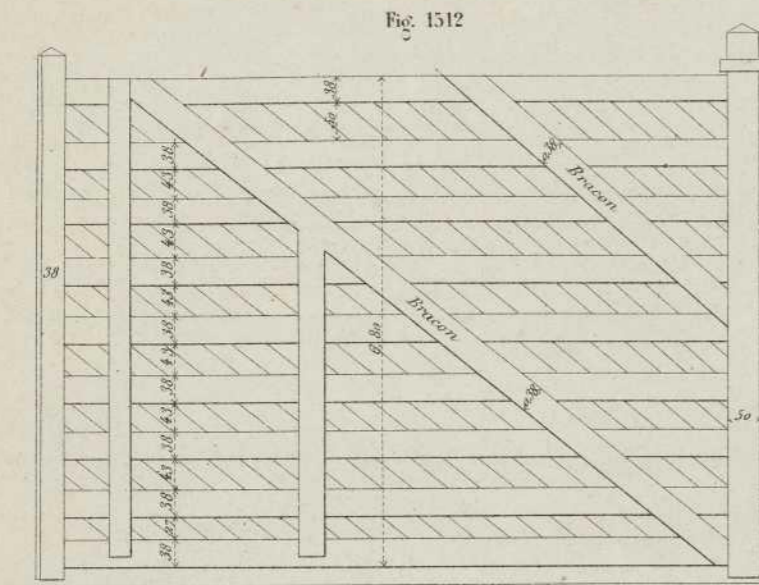








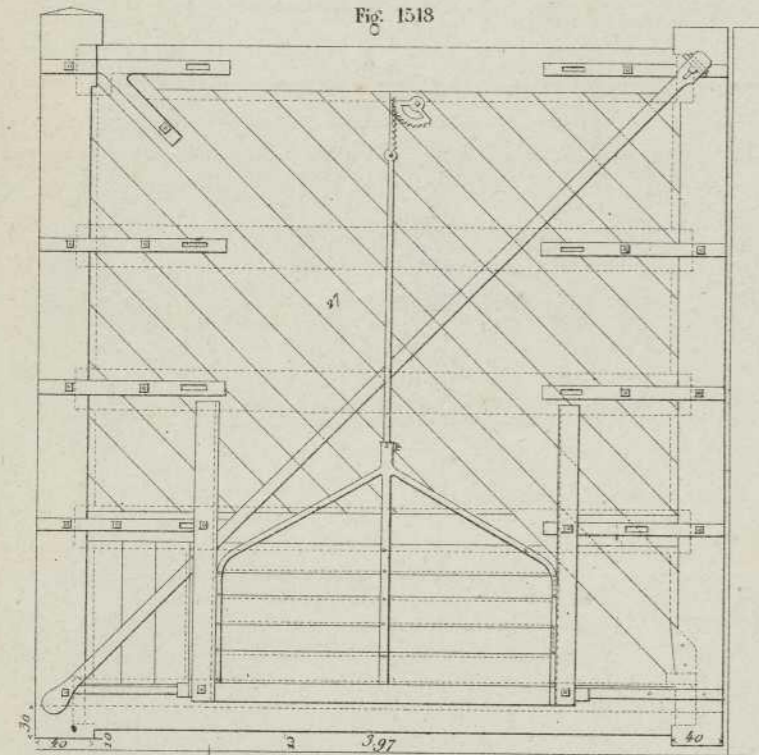
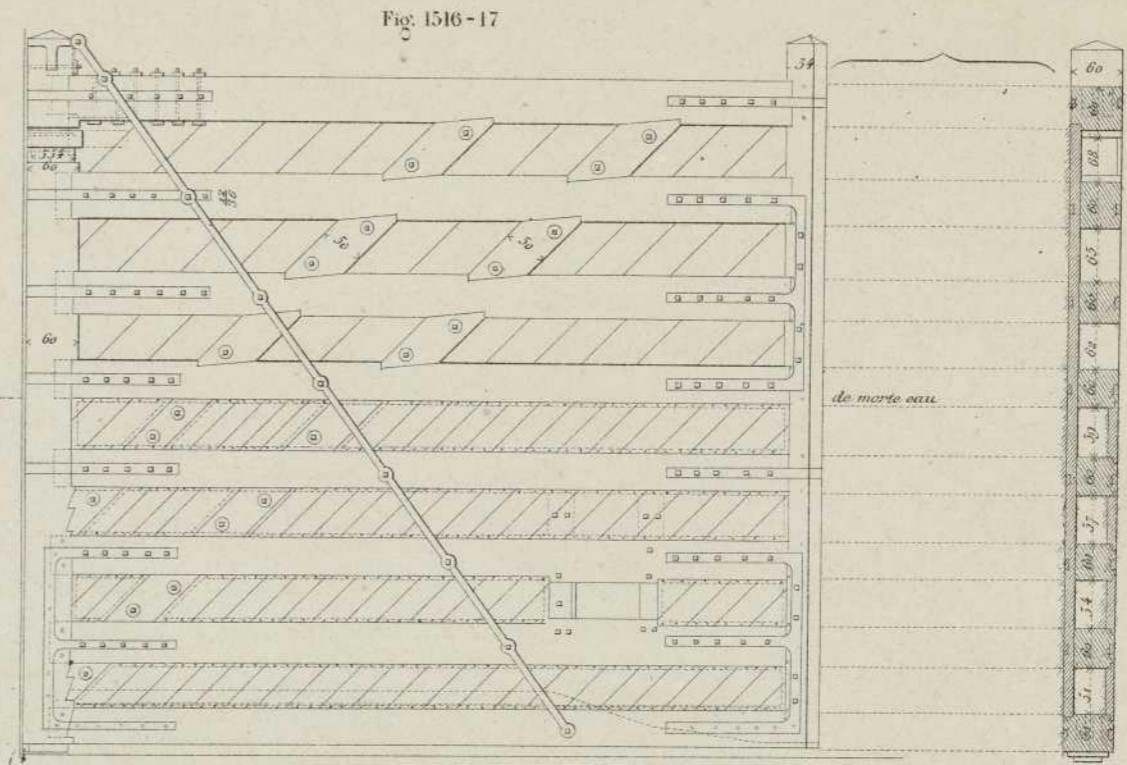
ECLUSES.



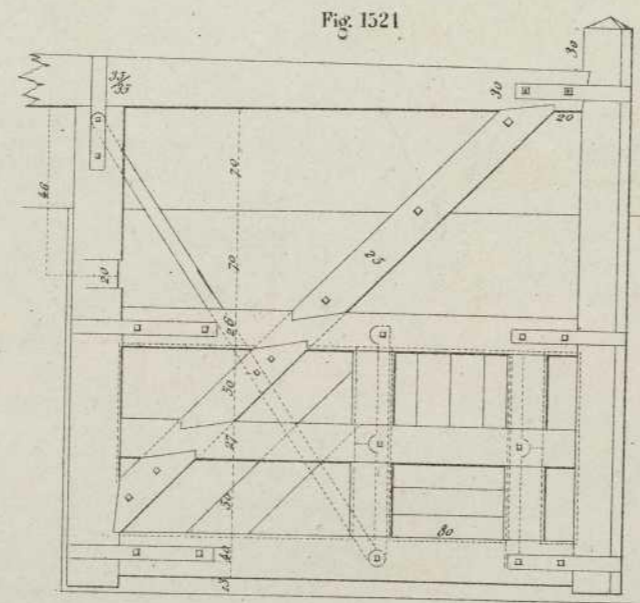
niveau des hautes mers.

Echelle pour la Fig. 1520.

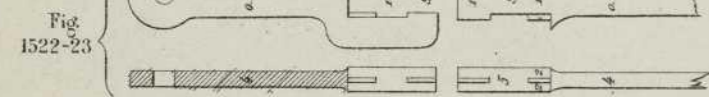
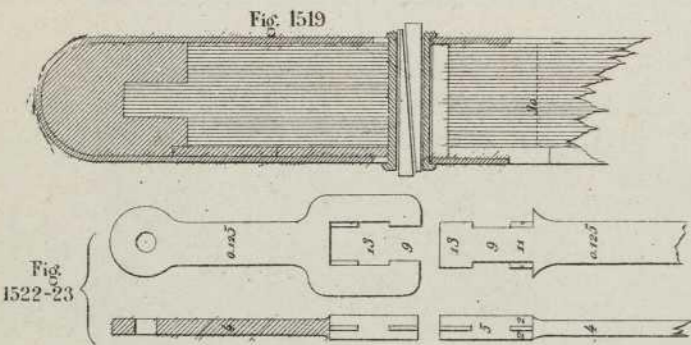
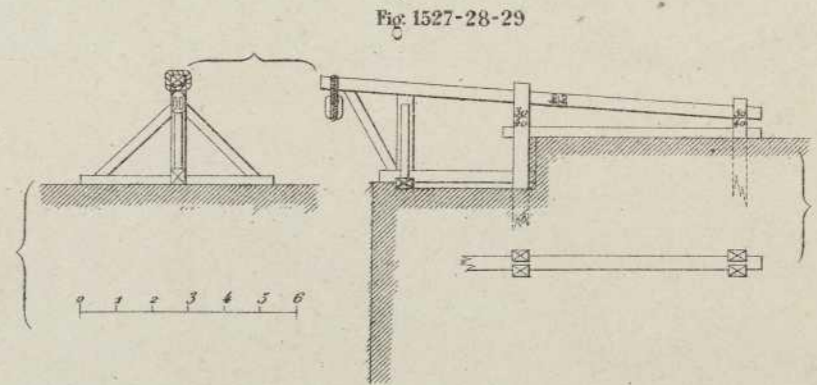
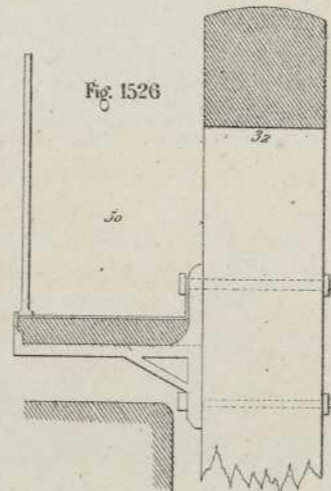
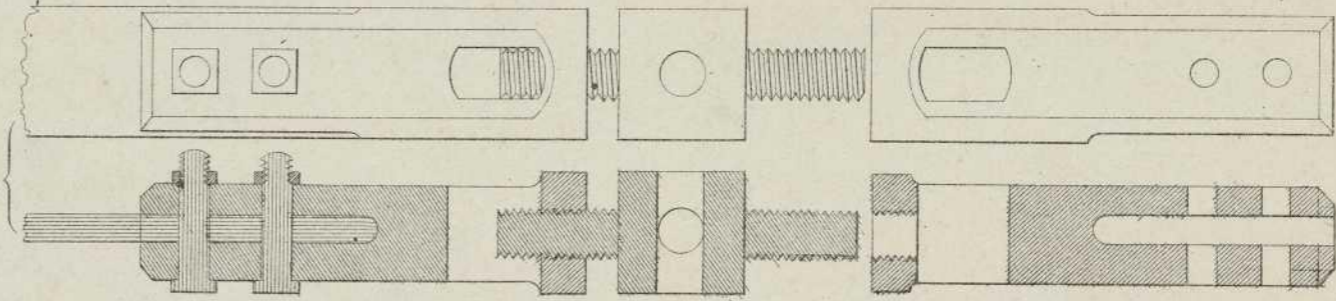
Echelle pour la Fig. 1516-17.



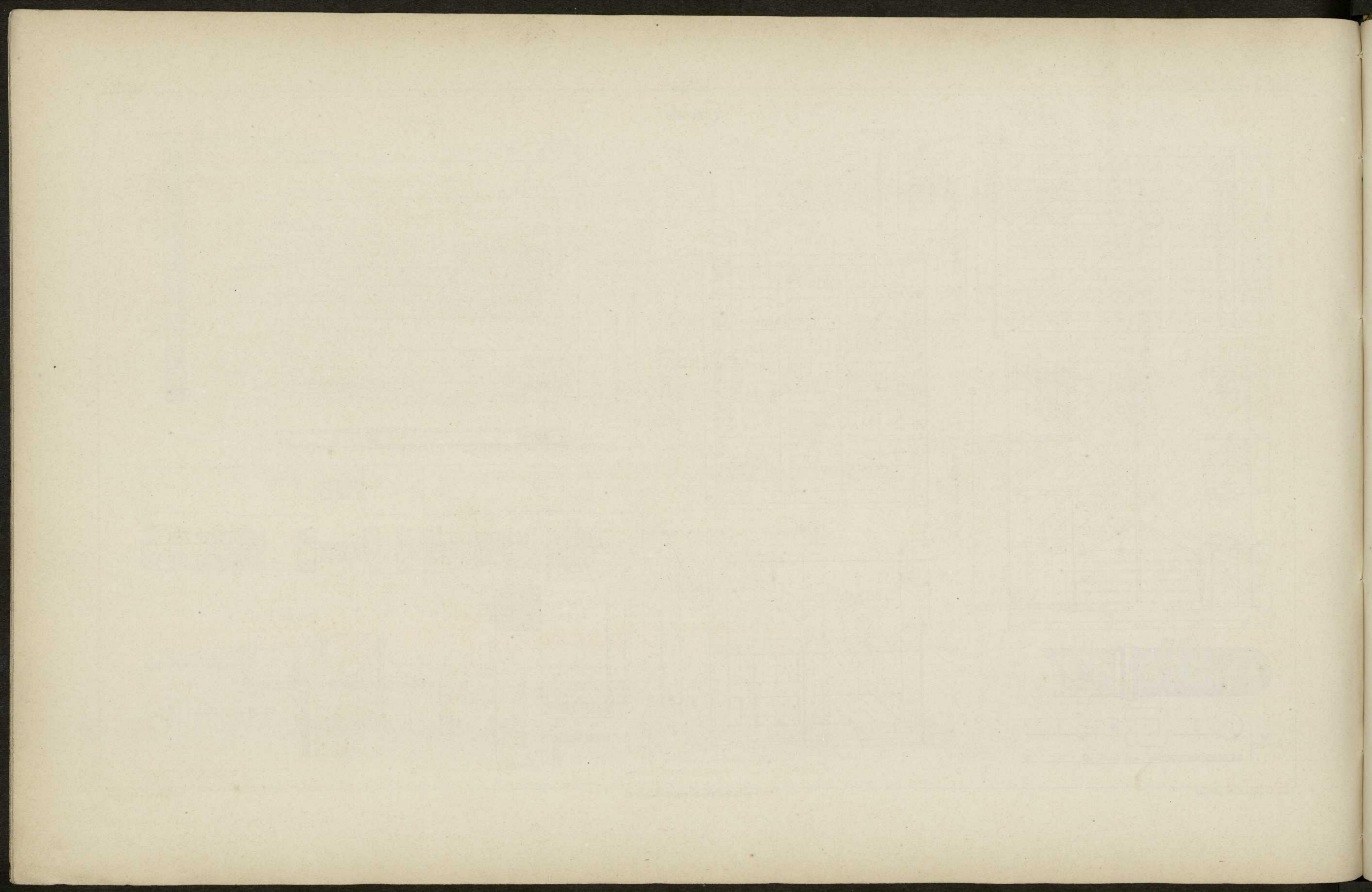
Echelle pour la Fig. 1518.



Echelle pour la Fig. 1521.

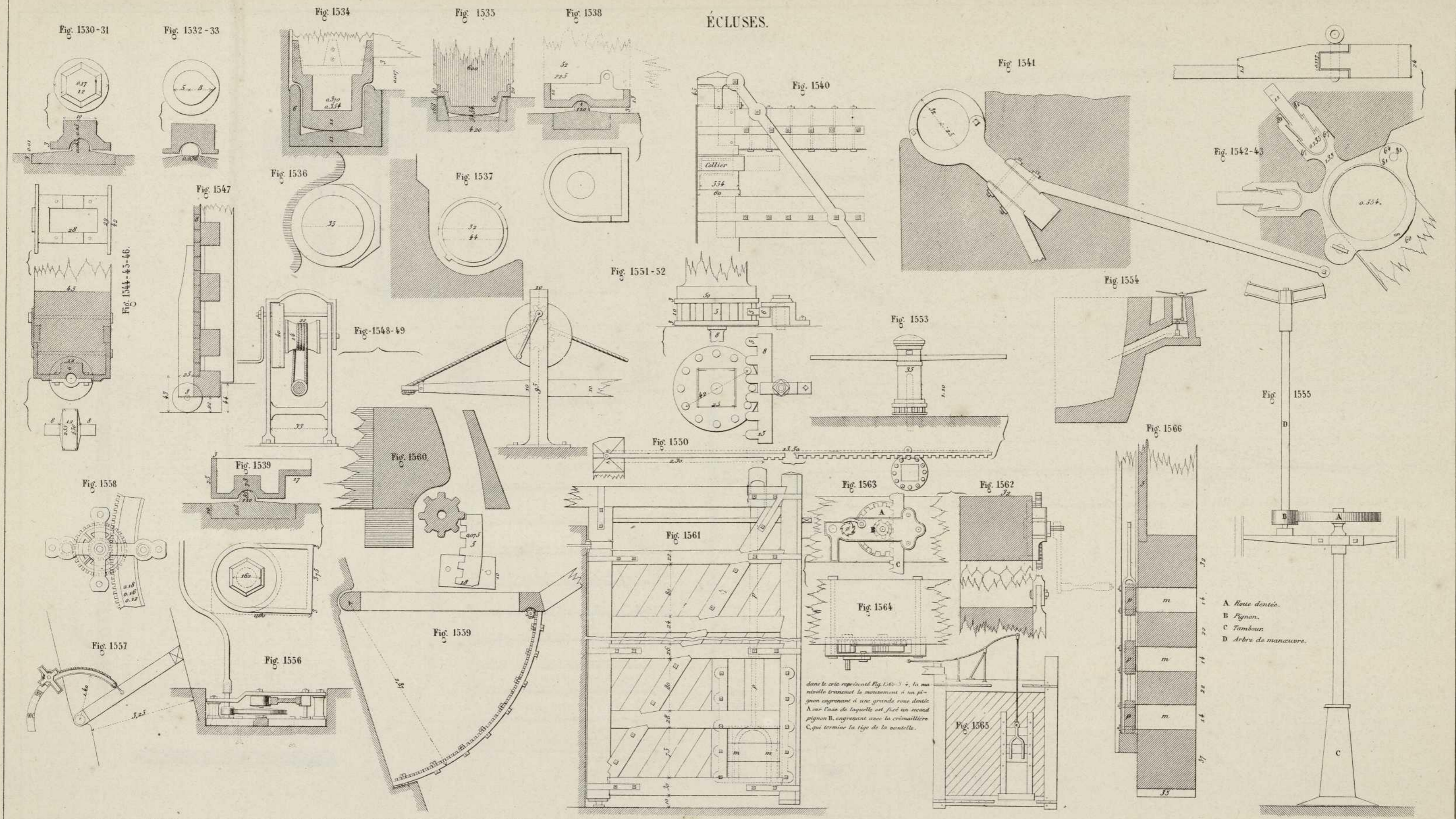








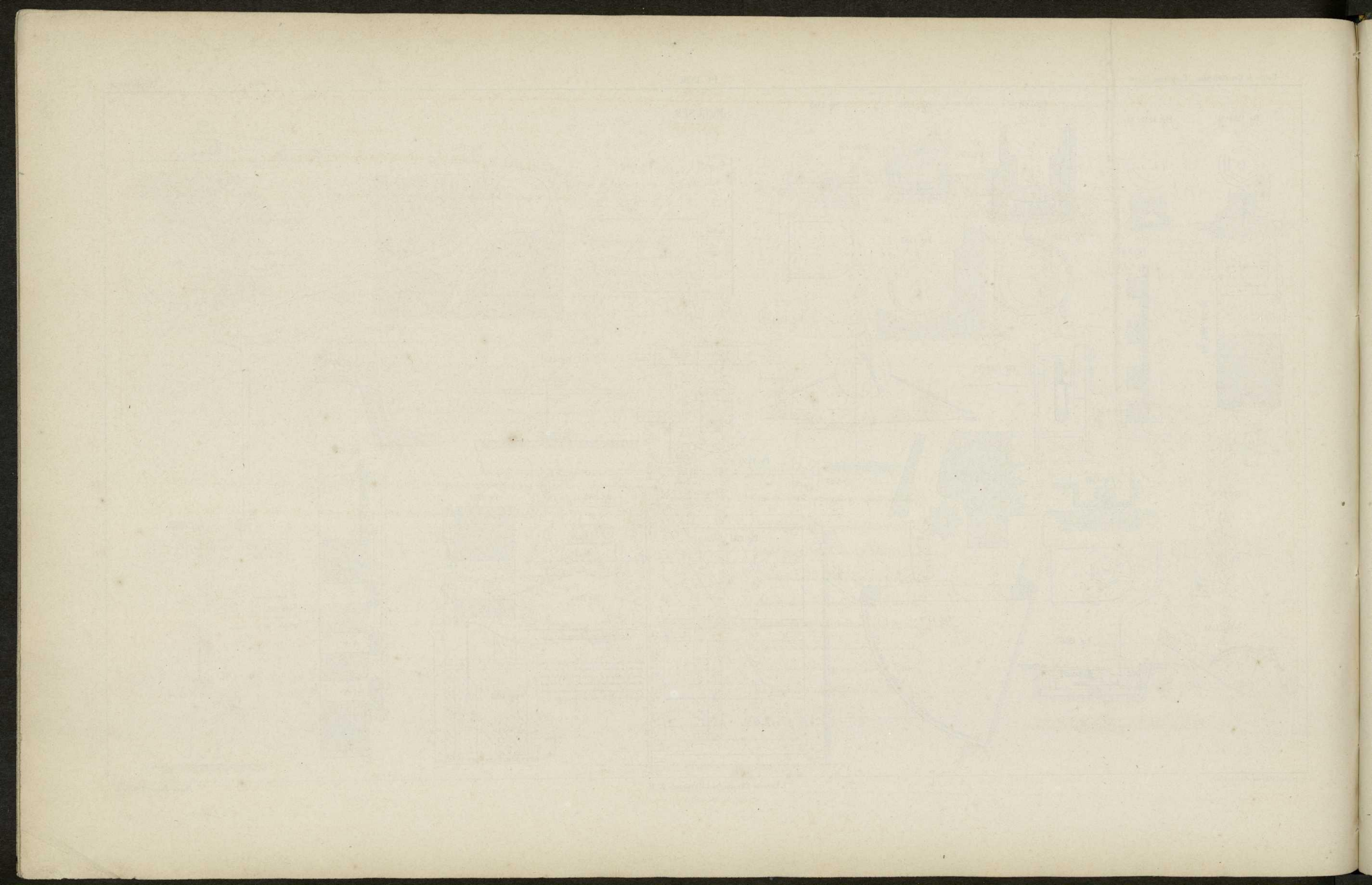
ECLUSES.



dans le cas représenté Fig. 1562-3, la manivelle transmet le mouvement à un pignon engrenant à une grande roue dentée A sur l'axe de laquelle est fixé un second pignon B, engrenant avec la crémaillère C, qui termine la tige de la vanne.

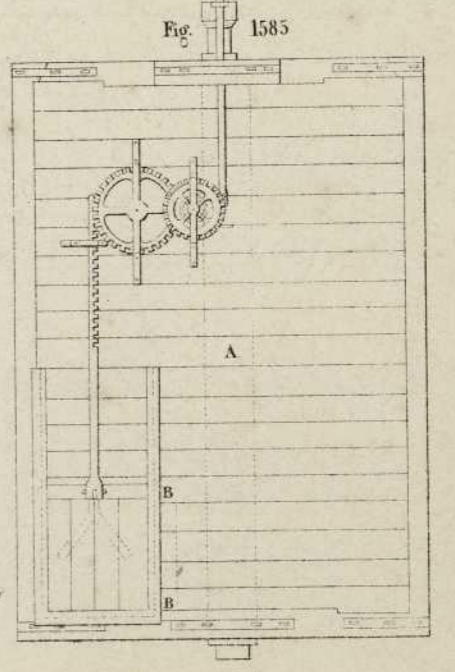
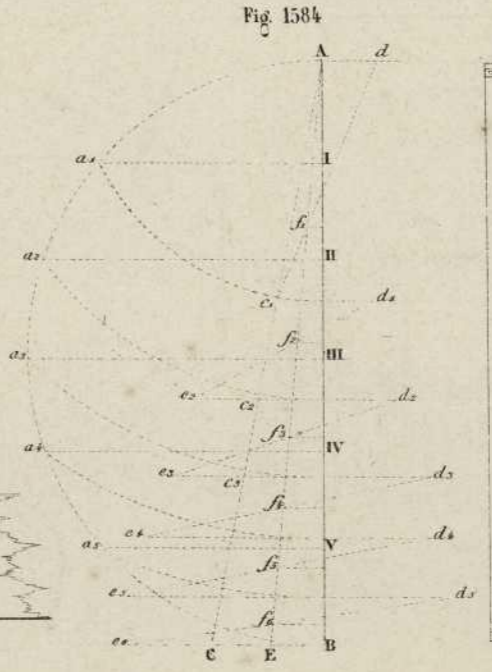
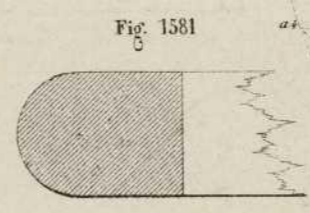
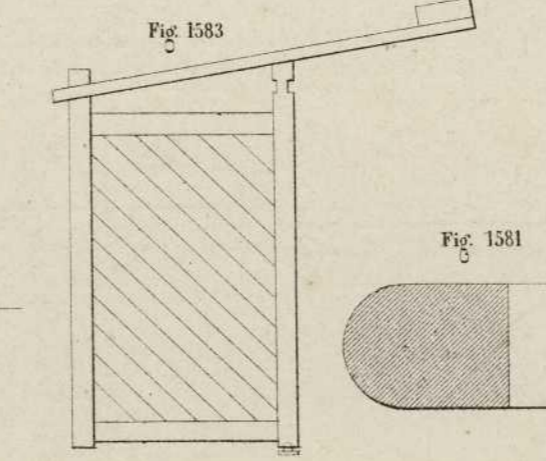
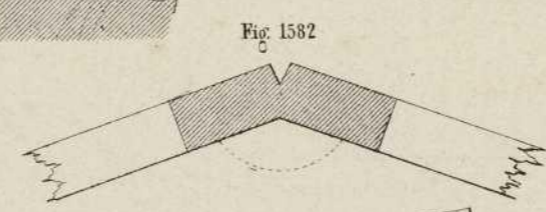
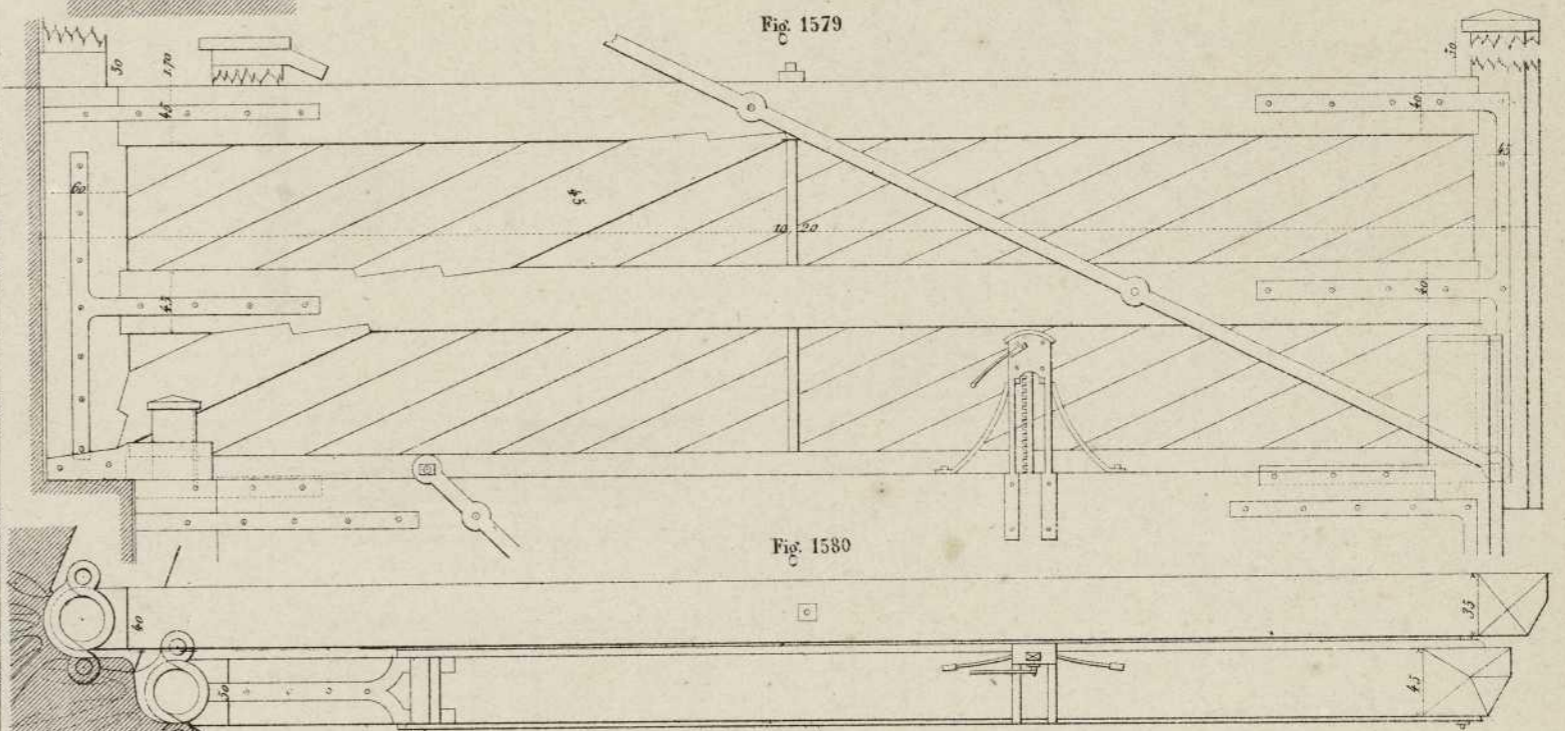
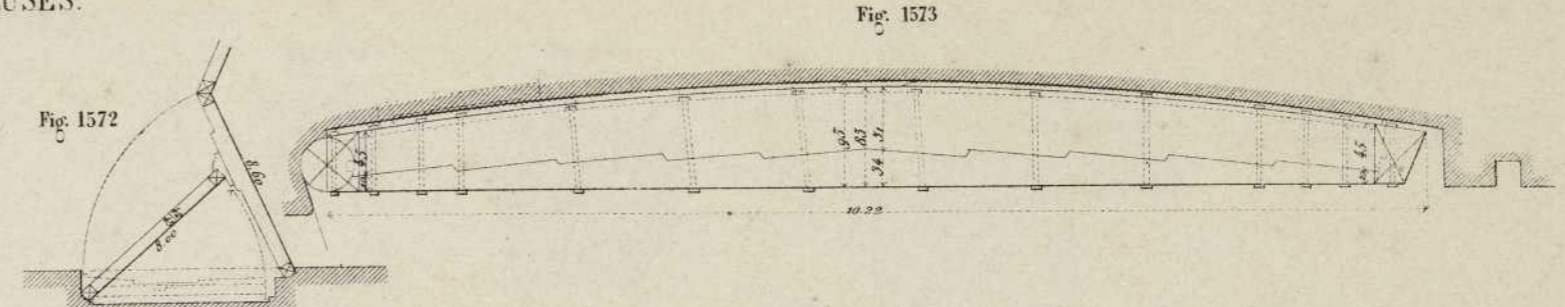
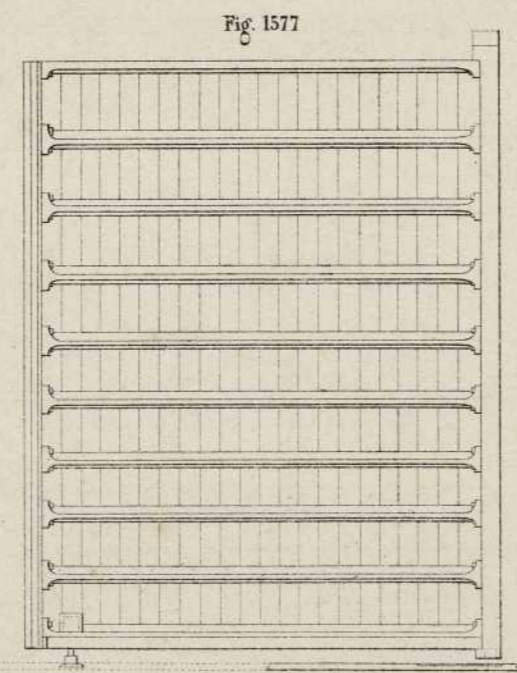
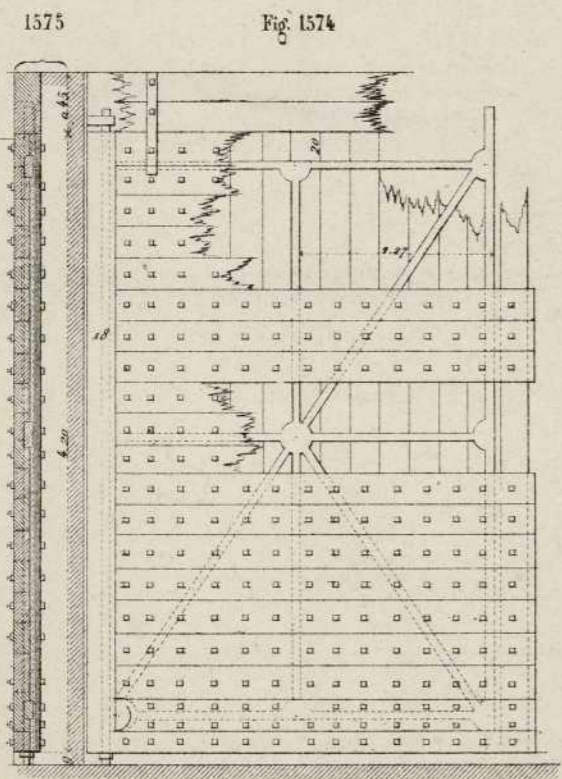
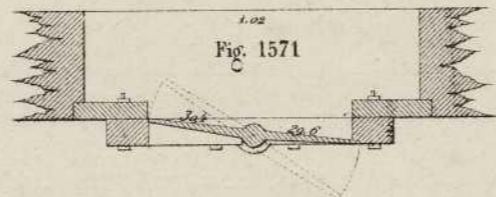
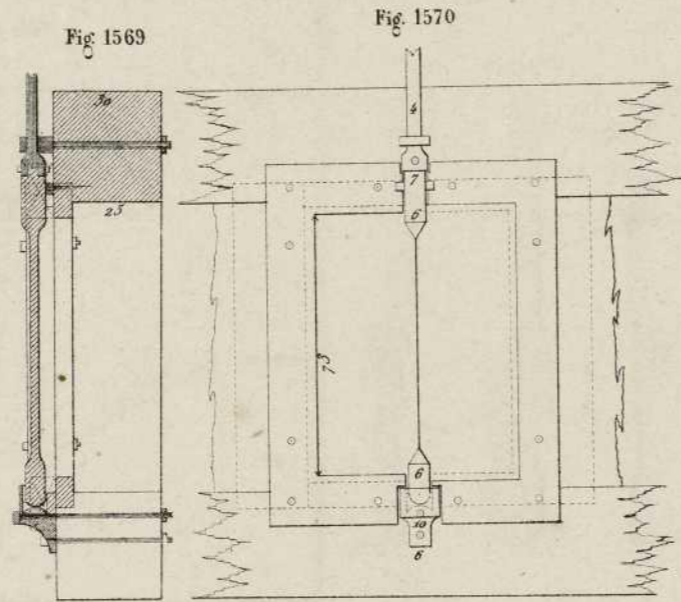
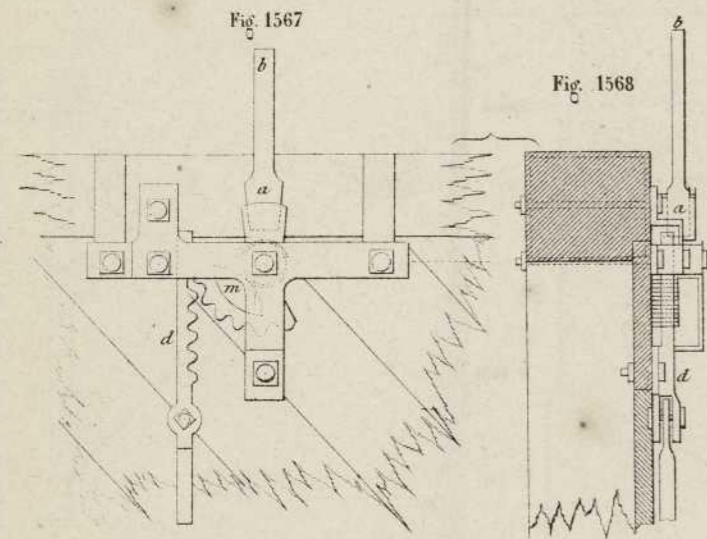
- A Roue dentée.
- B Pignon.
- C Tambour.
- D Arbre de manœuvre.



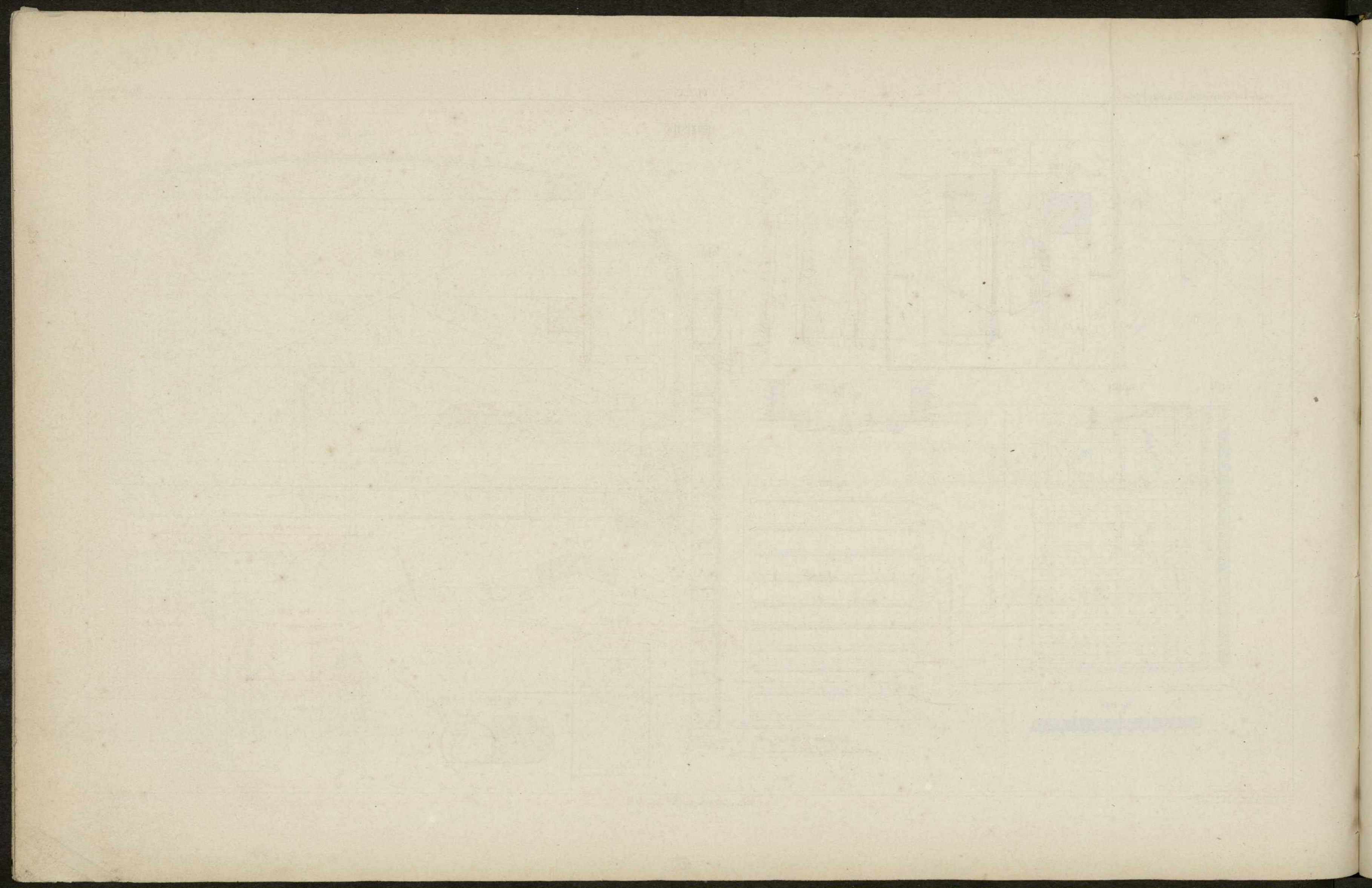




ÉCLUSES.

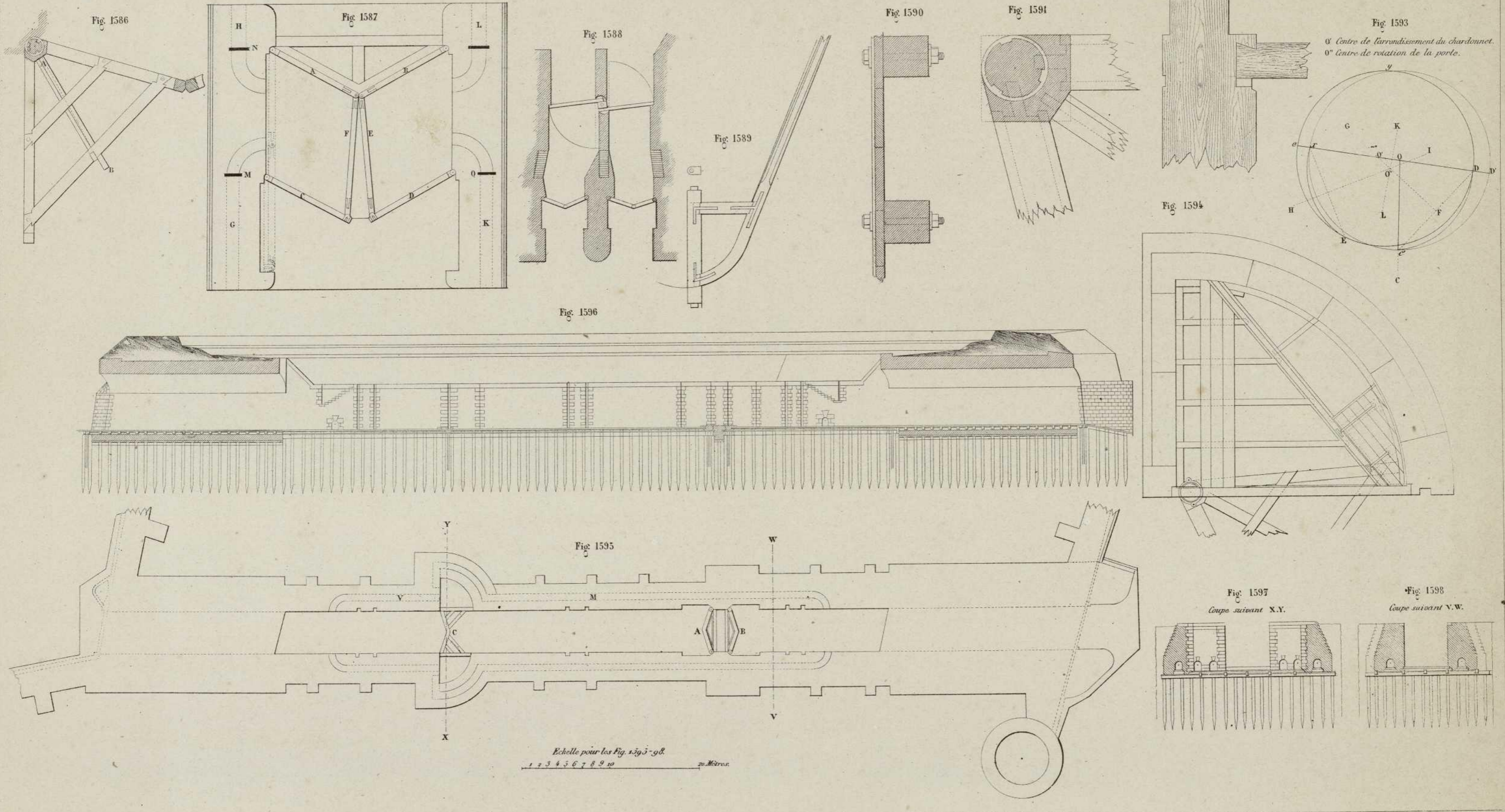








ECLUSES.

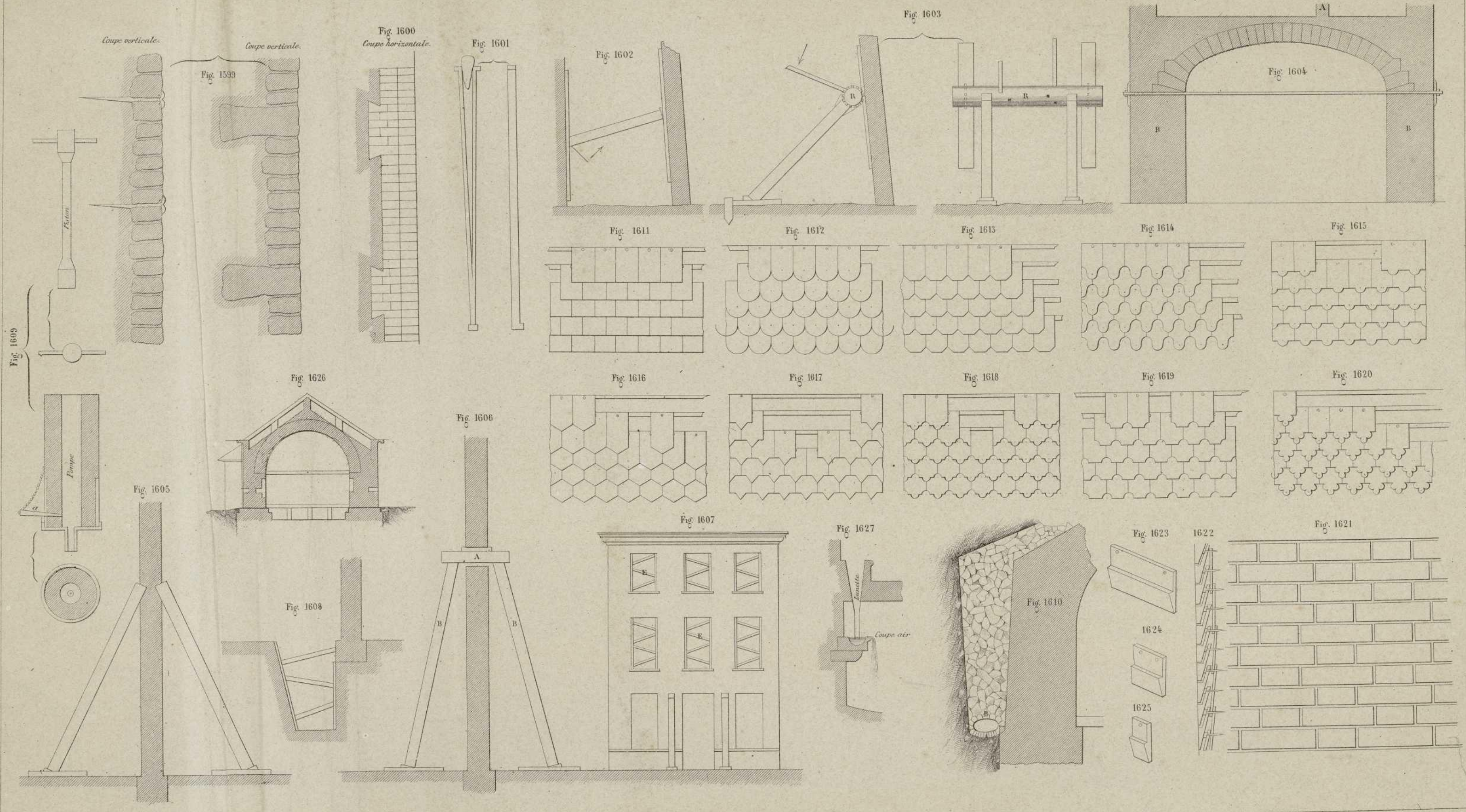


Echelle pour les Fig. 1595-98. 1 2 3 4 5 6 7 8 9 10 20 Mètres.













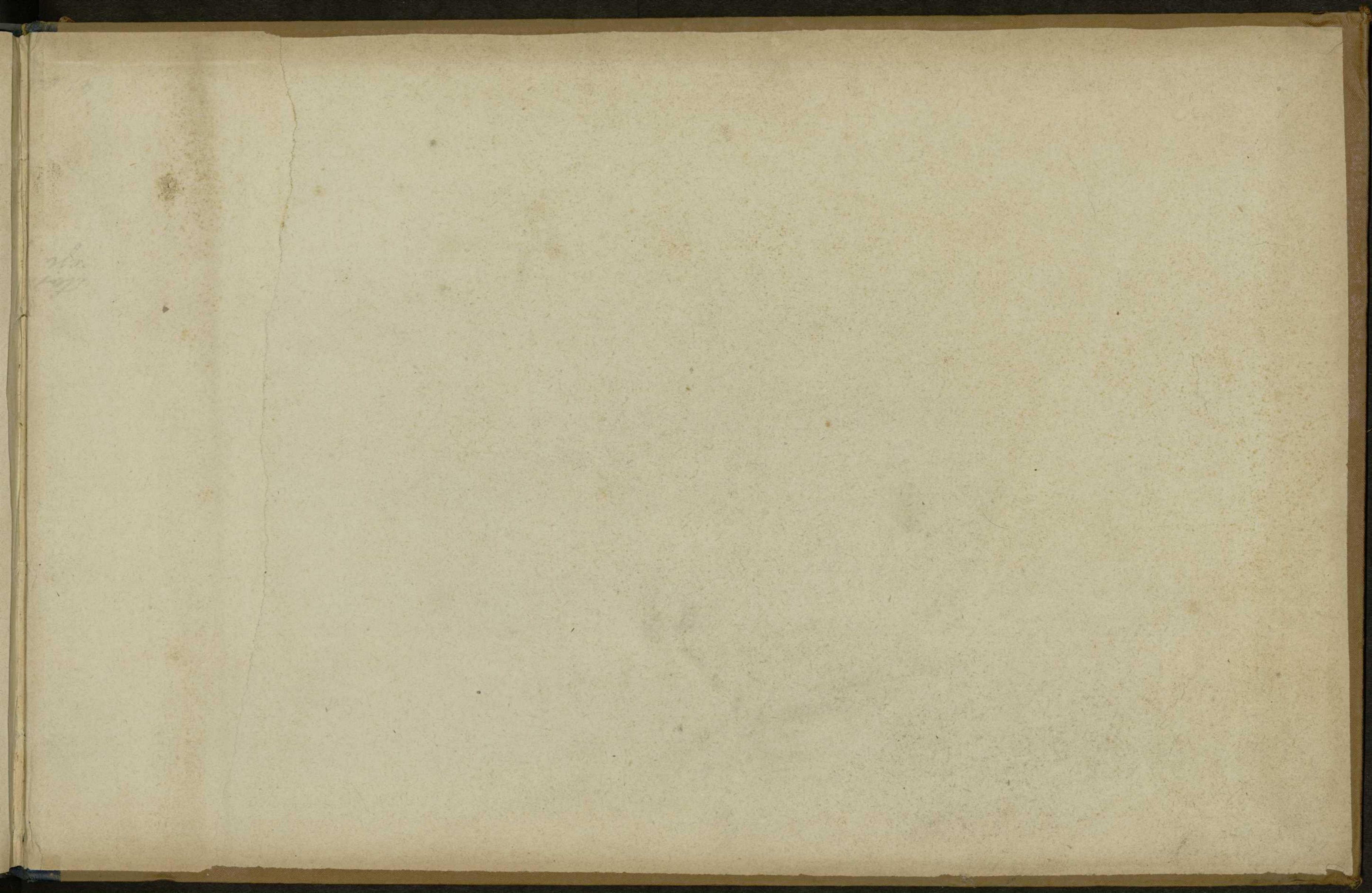


















DEMOU  
COURS

DE  
CONSTRUC

ATLAS

6.715